



PRODUCT SPECIFICATIONS

Exclusively Designed • INTERNATIONALLY RECOGNIZED™

Nautilus 60/40 Model # KS83322{xx}

Product Features:

- Natural Copper
- Drop-in or Undermount Application
- Without Overflow
(Non-Overflow Drain Required)
- Flat Edge Only
- Dark Smoke or Shiny Copper Finish



This Product Complies With:

- SGS USTC
- IAPMO IGC 194

Measurements:

- Width: 33" (83.8 cm)
- Depth: 22" (55.9 cm)
- Fits 3-1/2" (8.9 cm) Drain
- Height: 10" (25.4 cm)

Recommended Accessories:

- D'vontz ® Basket Strainer with Stopper
- Disposal Kit

PRODUCT DIMENSIONS

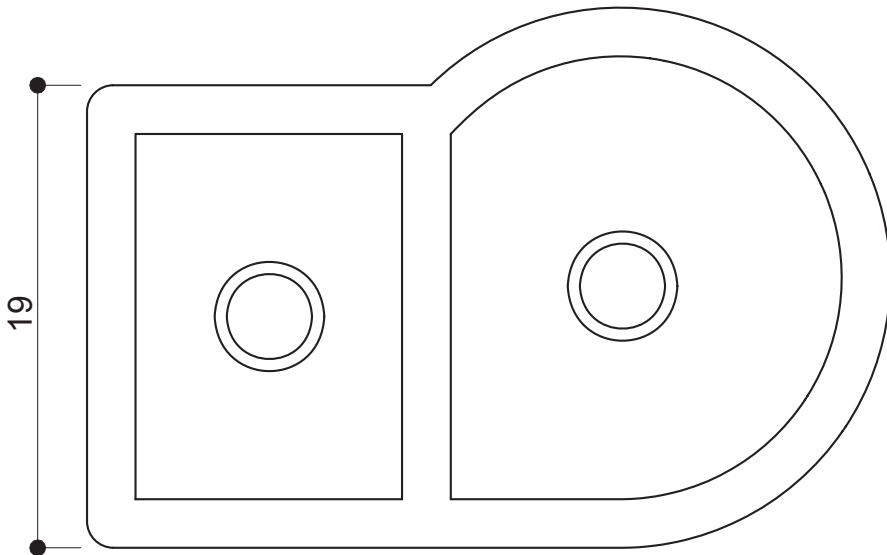

ALL DIMENSIONS ARE APPROXIMATE (+/- 1/2") AND ARE FOR REFERENCE ONLY.

THE ACTUAL SINK MUST BE USED FOR CUT TEMPLATE AND/OR HOLE PLACEMENT.

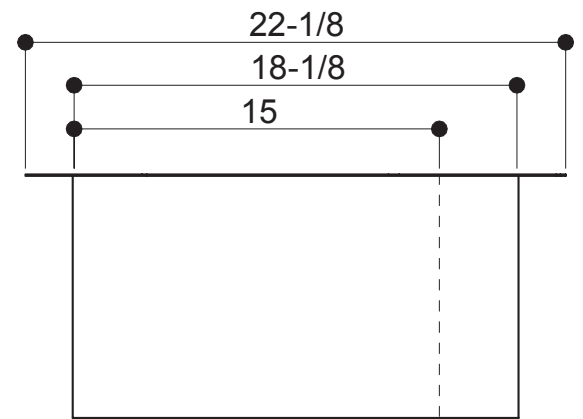
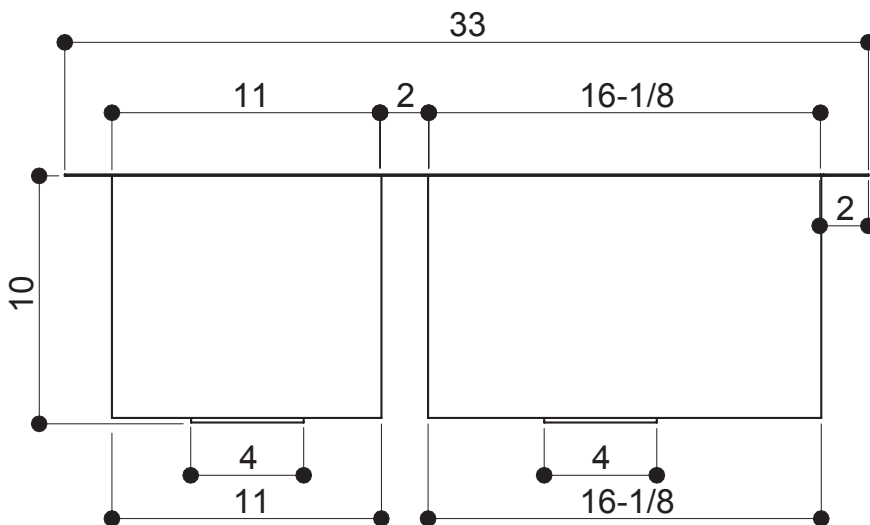

Please install this product according to the installation guide and all local plumbing codes.