

Installation/Operating Instructions

Revelation Video Projector Mount

Caution:

- ① Read instructions completely before proceeding.
- ② Follow instructions carefully. Installation contrary to instructions invalidates warranty.
- ③ Take great care when handling both first surface mirrors. They will most often come covered with a protective film. Remove this film after installation and prior to projecting images. If cleaning is necessary, do so very lightly with glass cleaner and a soft, lint free cloth.
- ④ Do not obstruct operation of door with fingers or any object. Serious injury or damage could result.
- ⑤ The Revelation is not designed to act as a structural support of ceiling framing. However, the trim frame is designed to support ceiling T-grid, tiles and drywall. **Equipment should not be allowed to rest on door at any time.**
- ⑥ Entire bottom of unit must be unobstructed to permit proper operation. Sufficient clearance (17" min.) must be allowed below door.
- ⑦ A minimum clearance of 13⁵/₈" is required above ceiling level for Models A and B, if plenum housing is used. If no plenum, the minimum clearance is 13" for both models.
- ⑧ Unit must be installed level (use a carpenter's level).
- ⑨ Unit operates on 110-120v AC 60 hz. current.

Note: Unit has been thoroughly inspected and tested at factory and found to be operating properly prior to shipment.

As Soon As Revelation Arrives

- ① Open carton and inspect for damage.
- ② Locate the following parts:
 - A. The unit itself
 - B. Controls

Planning

- ① Based on screen location and projector specifications, determine proper position for projector installation. (First see "Choose a projector based on its light path" on page 3. Then read "Where to install the Revelation" below.)
- ② Confirm that there is at least 13⁵/₈" available above the ceiling for Model A and Model B, if plenum housing is used. If no plenum, the minimum clearance is 13" for both models.
- ③ Arrange to provide service access to electrical control box and plenum housing. (Draper offers an access door; contact for details.)
- ④ If connecting duct work to the plenum housing, plan for position and length of duct work. (See guidelines under "Installing the Plenum Kit" on page 6.)

Where to install the Revelation

To determine where to mount the Revelation, you need to know the following:

- ① The projector manufacturer's recommended throw distance (TD). Typically, a minimum and maximum range is provided per screen size. Select a throw distance that is 6" greater than the minimum and 6" less than the maximum stated. We recommend the average of the two numbers. For example, if the range given is 228" max. and 142¹/₂" min., then use a number between 222" and 148¹/₂". We recommend using the average of 185¹/₄" as the TD.
- ② The distance from the center line of the lens to the bottom of the projector's feet (CL).

To find the mounting point (m = back edge of the rough cut) use the following formula:

$$y = 15" + CL \qquad z = TD - y \qquad m = z + 8"$$

Remember:

CL = Distance from center line of lens to bottom of projector's feet.

TD = Manufacturer's horizontal throw distance for the selected screen size.

m = Calculated mounting point (mounting point is back edge of rough cut as measured from screen surface.)

As an example, if you are using a projector with recommended throw distance (TD) of 185¹/₄" for a 100" diagonal image, and its CL dimension is 4", calculate the mounting point as follows:

$$\begin{array}{lll} y = 15" + CL & z = TD - y & m = z + 8" \\ y = 15" + 4" & z = 185\frac{1}{4}" - 19" & m = 166\frac{1}{4}" + 8" \\ y = 19" & z = 166\frac{1}{4}" & m = 174\frac{1}{4}" \end{array}$$

In the example above, the distance from the screen to the back edge of the rough cut would be 174¹/₄". (Formula has a ± 6" accuracy).

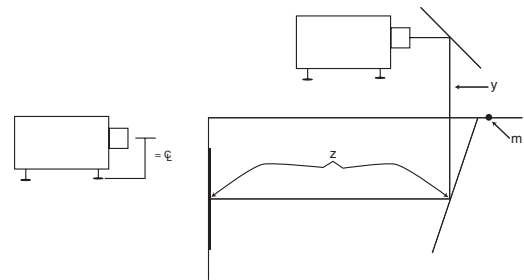

Formula to find m (mounting point is back edge of rough cut farthest away from projection screen).

$$y = 15" + CL \qquad z = TD - y \qquad m = z + 8"$$

where: CL = centerline of lens to bottom feet
TD = throw distance
Accuracy: ± 6"

Hanging Unit

The Revelation may be installed in a variety of ways. Typically, it is recessed above the ceiling and supported by six (6) ³/₈" threaded mounting rods. The bottom of the main pan should be recessed approximately 3" above the finished ceiling. The threaded rods should pass through mounting holes supplied in each corner and secured by nuts above and below. The unit should then be guy wired or blocked to prevent swinging.

All installations should observe the following guidelines:

- ① Installer must ensure that all fasteners and supports are of adequate strength to securely support Revelation and projector.
- ② Fastening methods must be suitable for mounting surface, and securely anchored so that vibration or abusive pulling on unit will not weaken installation.
- ③ Unit should be level, with weight shared more or less equally by all six threaded mounting rods.
- ④ Bottom of unit must be unobstructed after installation. 17" minimum clearance is required below the door.
- ⑤ Access should be provided to electrical control box in case service is required.
- ⑥ Place on top of T-grid so it fits into 2' x 2' grid style ceiling. Can also be used in reveal style grid without covering up reveal.



- ⑦ Do not use unit to support adjacent light fixtures, etc.
- ⑧ Do not complete the ceiling below unit until electrical connections have been completed and unit has been operated successfully.
- ⑨ We recommend that safety cables be attached to the Revelation for added security (a sound installation practice with overhead equipment).

Electrical Connections

Unit operates on 110-120v AC, 60 Hz. current.

Opening the access cover on the electrical control box exposes terminals for field connections. Unit is shipped with internal wiring complete. Wire for connecting unit to switch(es) and to power supply should be furnished by electrician. Connections should be made in accordance with wiring diagram on page 5, and wiring should comply with national and local electrical codes. All operating switches should be "off" before power is connected.

Operation

When unit is first operated, be cautious! If door does not begin to open momentarily when switch is flipped "down", return switch to "off" and free door and/or recheck electrical connections before proceeding. Cycle door down and up several times to confirm satisfactory operation.

Single Station Control—Moving 3-position switch to "down" position will start door down. Moving switch to "up" will start door up. When door is fully down or fully up, it will automatically be stopped by factory set limit switches. Whenever switch is placed in center "off" position, operation will stop.

Multiple Station Control—Each switching station has a three-button switch with "up", "down", and "off" buttons. Door starts up or down when appropriate button is pressed, and may be stopped by pressing "off" button. Factory set limit switches stop door automatically when door is fully up or fully down.

Key Operated Switch—If ordered, a single station, key-operated three position (up/off/down) switch is available for this unit.

Video Interface Control (VIC12, VIC12 Modified)—This optional control device allows the Revelation switch to control the operation of a Draper motorized projection screen via relay.

Infrared or Radio Frequency Remote Control—A three-button transmitter is provided, with "up", "down", and "stop" buttons. Door starts up or down when appropriate button is pressed, and may be stopped by pressing "off" button. Factory set limit switches stop door automatically when door is fully up or fully down.

Installing Projector

The Revelation has a grounded 110-120v AC, 60Hz outlet for projector power supply. Power is supplied to this outlet at all times.

Holes are provided for power and control wiring.

Install a projector with the capability to invert its image.

Place the projector into the sliding inner pan so that the center of the projector lens is aligned L to R with the center of the upper mirror. Position the projector lens as close as possible to the upper mirror without the reflected light path striking any part of the projector. AN EXTENSION PLATE IS PROVIDED IF THE FEET OF YOUR PROJECTOR SIT INSIDE THE OPENING OF THE INNER PAN. The extension is designed to support the front legs of your projector and the folded up edge can be used as a stop to help reposition the projector when removed. Adhere the extension plate only after you have adjusted the image and marked the position of the plate.

Establish exact placement through trial and error using the various adjustments integrated throughout the design of the Revelation. The upper mirror can be moved up one inch to accommodate taller projectors. Make the necessary connections and plug the power cord of the projector into the receptacle provided in the electrical chassis. **POWER TO THE REVELATION SHOULD BE TURNED OFF ANY TIME ELECTRICAL CONNECTIONS OR**

MECHANICAL ADJUSTMENTS ARE MADE TO THE REVELATION! Cycle the mirrored door down to the lowered position. You are now ready to move on to adjusting the image to the screen.

Please Note

If Glass Shield is provided, see separate instructions (provided with Glass Shield).

Adjusting Image

First, use your projector's operating manual to establish proper orientation of the image and adjust the lens position to achieve the desired image width and location.

Next, use the Revelation's adjustments to adjust the height of the image on the screen.

The Revelation has two adjustments:

- ① Always start by sliding the inner pan which holds the projector either backward or forward depending on desired location of image. Sliding the inner pan towards the projection screen will change where the image strikes the mirror on the door, and lower the projected image. Inner pan has a travel range of approximately 8".
- ② Opening the mirrored door even further into the room will lower the projected image. The limit switch is factory set to let the door open into the room at a 45° angle. The door can open approximately 10° further by changing the limit switch's position.

Adjust the door only if your projector is equipped with keystone correction or a certain amount of keystoneing can be tolerated.

To adjust the limit switch of the door:

TOOLS: screwdriver/Allen wrench ($\frac{3}{16}$ "); electronic level or protractor or other tool to measure angles.

Turn the unit on and open the door to its factory set position. Record the angle measurement.

CAUTION: ANY ADJUSTMENTS TO THE LIMIT SWITCHES SHOULD BE DONE WITH POWER TO THE REVELATION TURNED OFF!

Locate the two limit switch brackets at the edge of the top mirror on the motor side of the pan. The top bracket controls the downward travel limit of the door and adjustments are made to this bracket. Note and mark current location of limit switch bracket. *The bottom limit switch bracket is set at the factory for proper closure alignment and should not need adjusting.*

Use a $\frac{3}{16}$ " Allen wrench to loosen the two screws on the limit switch bracket and slide the bracket toward the electrical chassis. A slight adjustment to the limit switch bracket will result in a significant movement of the door. It is recommended that the limit switch be adjusted in small incremental moves of $\frac{1}{8}$ ".

Tighten the screws. Keeping hands and tools clear of the limit switch, connect the power. The door should open further. Record the new angle and check the position of the image on the screen.

If the position of the image on the screen is satisfactory, close the door and make sure the screws are completely tight.

If the position of the image needs adjusting, leave the door open, disconnect the power, loosen the screws and slide the bracket toward the motor to open the door more, or slide the bracket closer to its original position.

Check alignment of image and repeat adjustment procedure as necessary. **AFTER ALL ADJUSTMENTS ARE COMPLETED, BE SURE TO TIGHTEN ALL LOOSENED SCREWS TO INNER PAN AND LIMIT SWITCH BRACKET!**

Securing Projector

Once all adjustments to the projector and Revelation are made, the projector should be secured into place using the eight projector standoffs provided. Two of the standoffs have a removable hook and loop material to be used at the rear of the projector for ease of removing the projector. The standoffs will ensure proper relocation of the projector after periodic maintenance or repair to

the projector. Just peel the adhesive backing from the bottom of the standoffs and place them around the projector as shown in the dimensional diagram. **IMPORTANT: ONCE THE ADHESIVE IS PLACED ONTO THE SURFACE OF THE INNER PAN IT IS VERY DIFFICULT TO REMOVE. IT IS VERY IMPORTANT TO PLAN AHEAD WHEN PLACING THESE STANDOFFS AROUND THE PROJECTOR.**

Choose a projector* based on its light path

A light path is the projector's spread of light and its relationship to the centerline of the lens. Since the Revelation folds a light path twice (bounces the image off of two first surface mirrors), it's critical to understand your projector's light path to know approximately where the image will land on the wall. Consult the projector manufacturer to determine its light path geometry.

Single lens projectors fall into one of four categories of light path geometry as depicted in the illustrations at right.

Light Path A

Single lens projectors with light path geometry "A" work well with the Revelation. Since the light is already projecting at a downward angle to the centerline, the image is projected further down on the wall resulting in a lower installation point for the projection screen. A projector with Light Path A mounted in the Revelation projects a light path similar to the same projector ceiling mounted with the centerline of its lens mounted approximately 2"-3" below the ceiling.

Light Path B

Single lens projectors with light path geometry "B" will work with the Revelation within certain limitations. The upper edge of the image runs parallel to the centerline of the lens. A projector with Light Path B mounted in the Revelation projects a light path similar to the same projector ceiling mounted with the centerline of its lens mounted approximately 6"-8" below the ceiling. By using the built in adjustment features of the Revelation, you should be able to bring the top of the image below the ceiling. Adjusting the ceiling closure door may introduce a keystone effect to the image. If your projector has a keystone correction feature you may be able to compensate for keystoneing.

Light Path C

Single lens projectors with light path geometry "C" will work with the Revelation within certain limitations. The portion of the image above the centerline of the lens projects at a gradual angle up towards the ceiling. A projector with Light Path C mounted in the Revelation projects a light path similar to the same projector ceiling mounted with the centerline of its lens mounted approximately 6"-8" below the ceiling. By using the built in adjustment features of the Revelation, you should be able to bring the top of the image below the ceiling. Adjusting the ceiling closure door may introduce a keystone effect to the image. If your projector has a keystone correction feature you may be able to compensate for keystoneing.

Light Path D

Single lens projectors with light path geometry "D" will not work with the Revelation. The portion of the image above the centerline of the lens projects at too steep of an angle to be lowered below ceiling level, even with the adjustment features built into the Revelation.

**Consult your projector manufacturer if in doubt about its light path geometry, throw distance or projector dimensions. Also, be sure your projector has the ability to invert its image.*

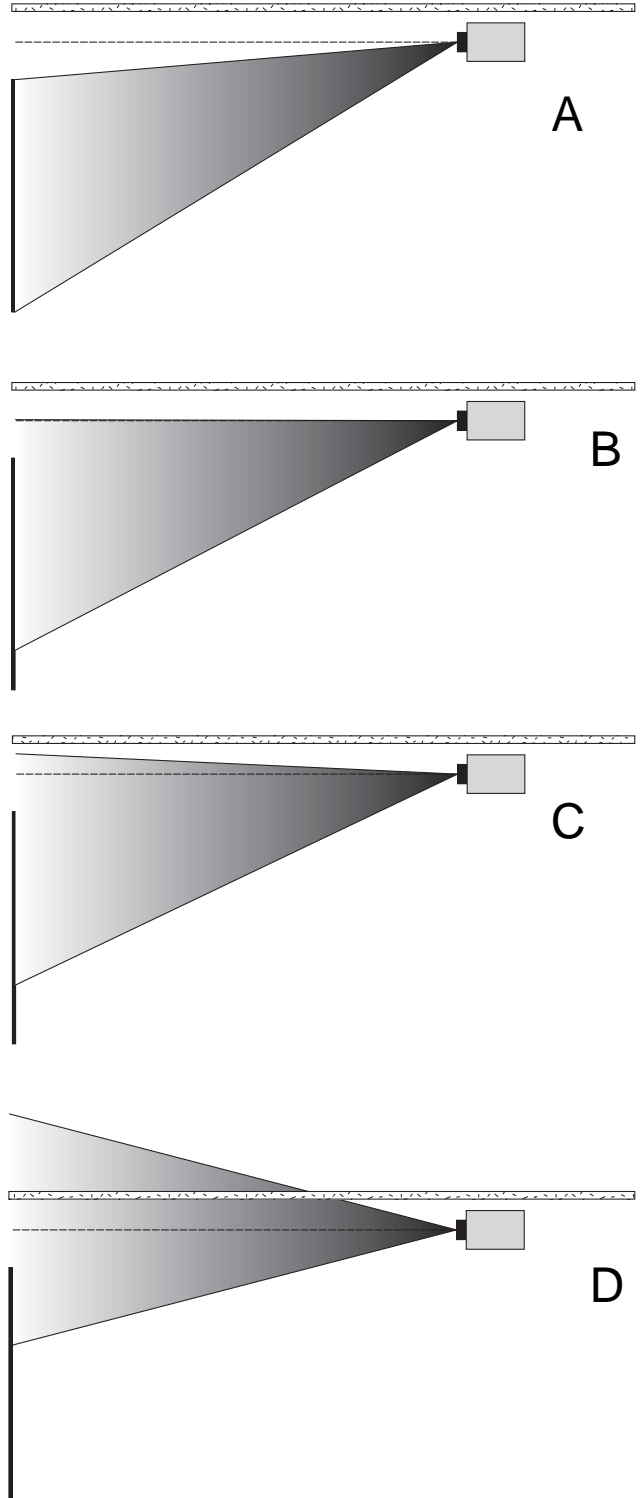

Revelation Dimensions

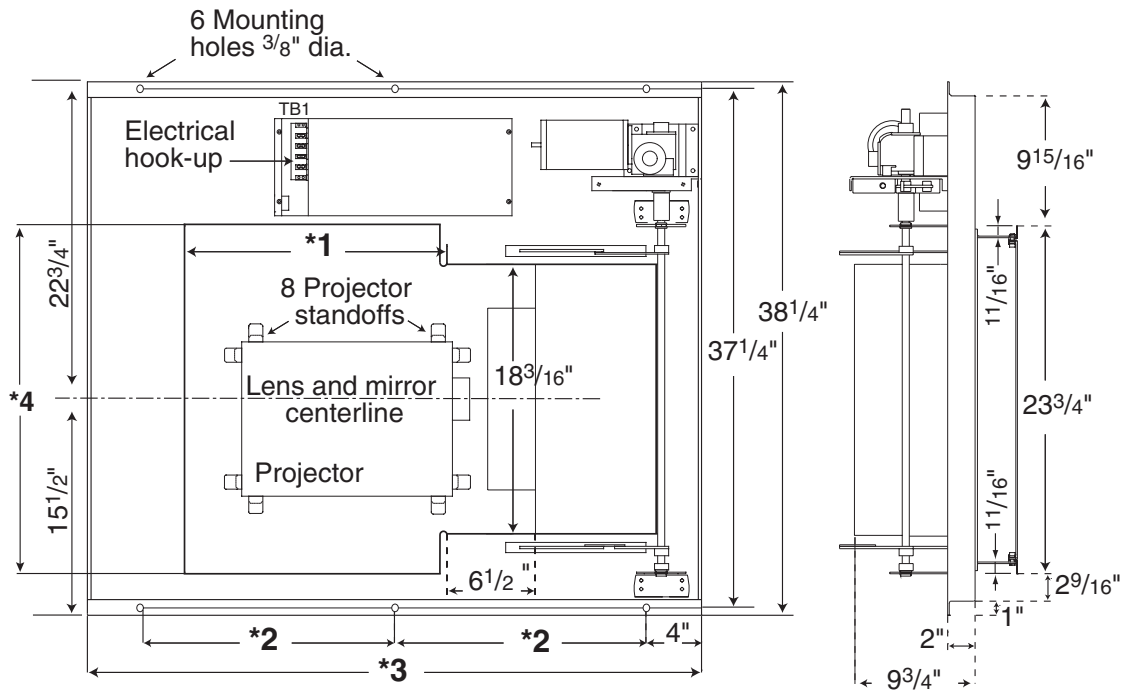

	Model A	Model B
*1	9 ¹ / ₈ "	18 ¹¹ / ₁₆ "
*2	13"	18"
*3	34"	44"
*4	21 ¹ / ₂ "	24 ¹³ / ₁₆ "

Minimum rough opening
23¹/₂" x 23¹/₂"

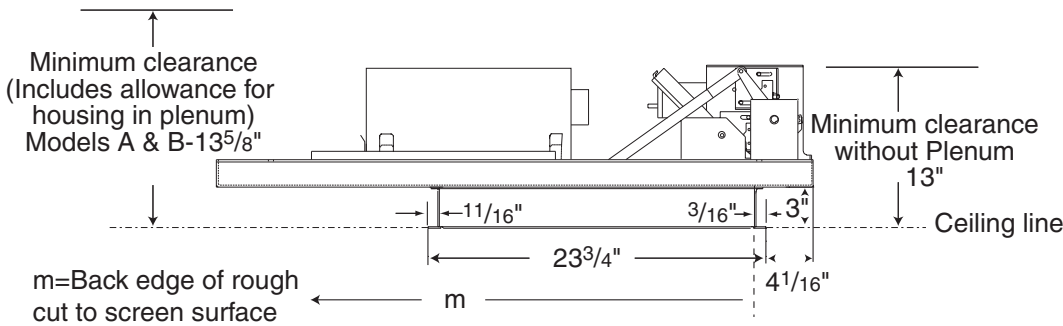

Revelation Dimensions & Data	Model A	Model B
Overall Unit Size (HWL)	13" x 38 ¹ / ₄ " x 34"	13" x 38 ¹ / ₄ " x 44"
Required Space Above Ceiling*	13 ⁵ / ₈ " x 38 ¹ / ₄ " x 34"	13 ⁵ / ₈ " x 38 ¹ / ₄ " x 44"
Clearance Below Ceiling	approx. 17"	approx. 17"
Rough Ceiling Opening for motorized door	23 ¹ / ₂ " x 23 ¹ / ₂ "	23 ¹ / ₂ " x 23 ¹ / ₂ "
Capacity	100 lbs.	100 lbs.
Door's Downward Travel Distance	approx. 17"	approx. 17"
Travel Time	9 sec.	9 sec.
Net Weight	85 lbs.	90 lbs.
Shipping Weight	215 lbs.	220 lbs.

Electrical Specifications	
Operating Voltage	110–120 VAC 50–60 Hz
Amperes	1 Amp**
Control Voltage	12 VAC
Motor Specifications:	
Voltage	110–120 VAC 50–60 Hz
Amps	.43
Torque	200 IN–lbs.

** Does not include any load placed on internal outlet.

Projector Space (HWL)—To fit within parameters of inner pan.
* 13⁵/₈" is overall height of Revelation with plenum housing (13" WITHOUT plenum).

U.S. patent number 6,379,012

Wiring Diagrams for Revelation without Plenum

Single Station Control

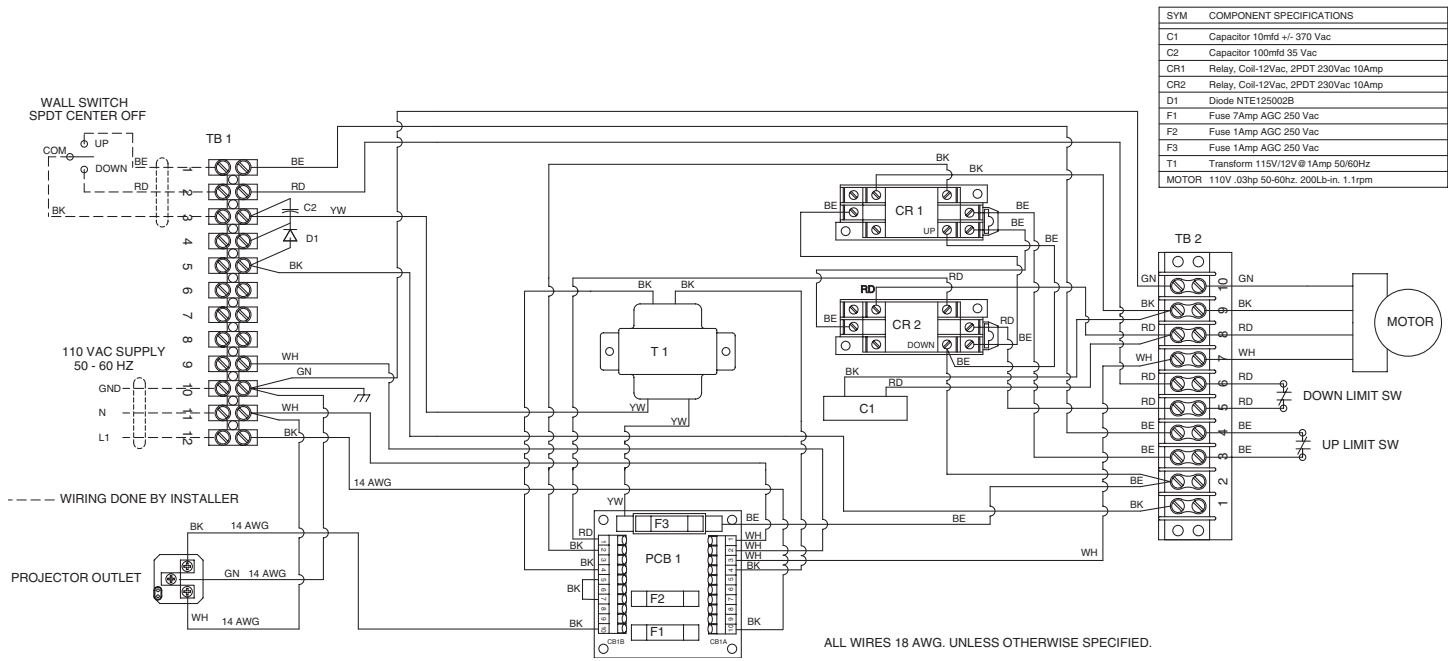

Low Voltage Multiple Station and Remote Control

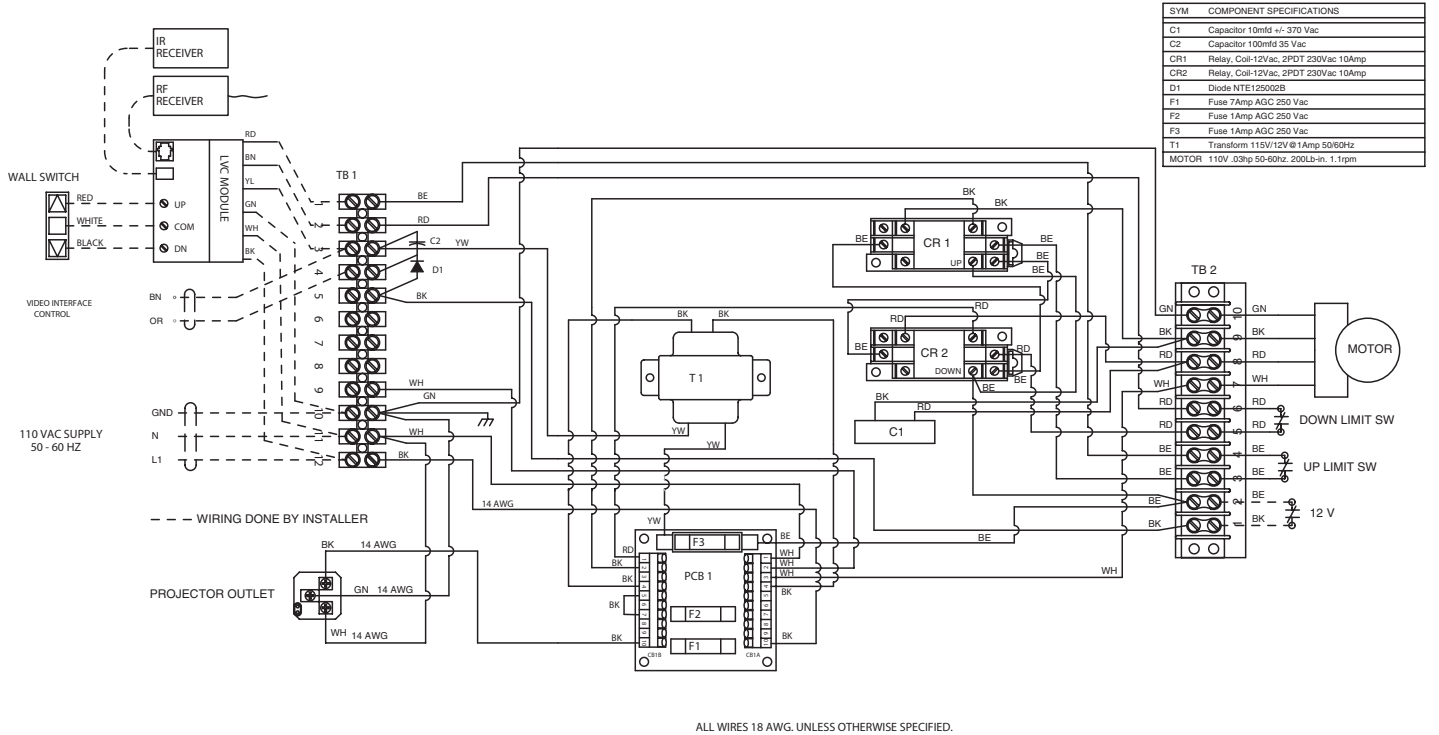

Field Installation of Plenum Kit

CAUTION! DISCONNECT POWER FROM THE REVELATION BEFORE INSTALLING PLENUM.

- ① Remove the covers from the electrical chassis in the Revelation.
- ② Disconnect the black 14 awg. wire that runs from the connector CB1B-10 (of circuit board PCB1) to the receptacle in the electrical chassis.
- ③ Install the pre-wired current sensor using two #6-32 x 1" [10] long screws provided. (SEE FIGURE #1.)
- ④ Connect each wire of the pre-wired current sensor as shown by DIAGRAM #1.
- ⑤ Install the two fan mount assemblies [5,6] to the main pan of the Revelation using the eight #10-32 x .375" [7,8] long screws provided. (SEE FIGURE #1.) Attach the long leads of the Exhaust Fan Assembly [6] to the end with the motor and lifting mechanism.
- ⑥ Using the wire clips [11] provided, lay in the wires from the fans as shown in FIGURE #1 and connect the fans to TB1-8 & TB1-9 as shown in DIAGRAM #1.
- ⑦ Replace the covers to the electrical chassis.
- ⑧ Apply the 1" wide Nylon [12,13] tape as shown in FIGURE #1.
- ⑨ Install the inner and outer plenum covers [1,2], and attach the mating end panel [3,4] as shown in FIGURE #2.
- ⑩ Fan mounting panels are designed to accept a standard 4" round duct. The exhaust flange is located on the motor/drive end of the Revelation and the input is located at projector end of the Revelation.

FIGURE #1

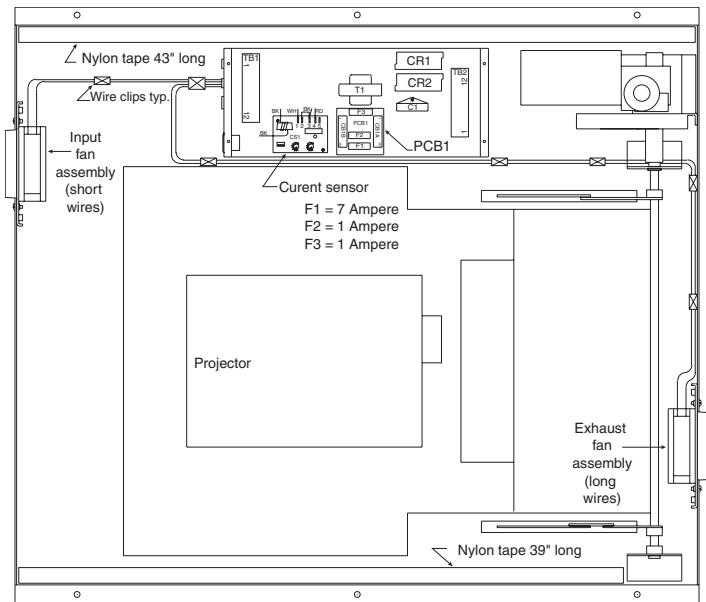

If duct work is connected to this unit, here are a few recommended guidelines you should keep in mind when installing the duct work:

- Air supply to the plenum should be cool enough to provide adequate cooling for your projector.
- Do not obstruct airflow through duct work. Inadequate airflow may result in excessive heat buildup inside the unit.
- Keep duct work length as short as possible. Recommended maximum total duct length is 30' (input plus exhaust).
- Keep the input-to-exhaust length ratio balanced and as small as possible to prevent air from being pushed into or drawn out of the room.

FIGURE #2

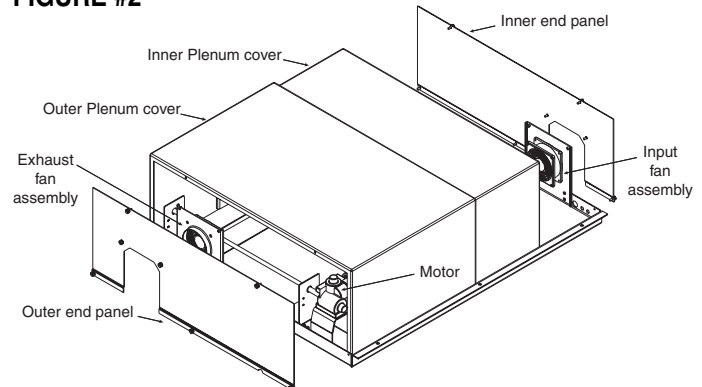
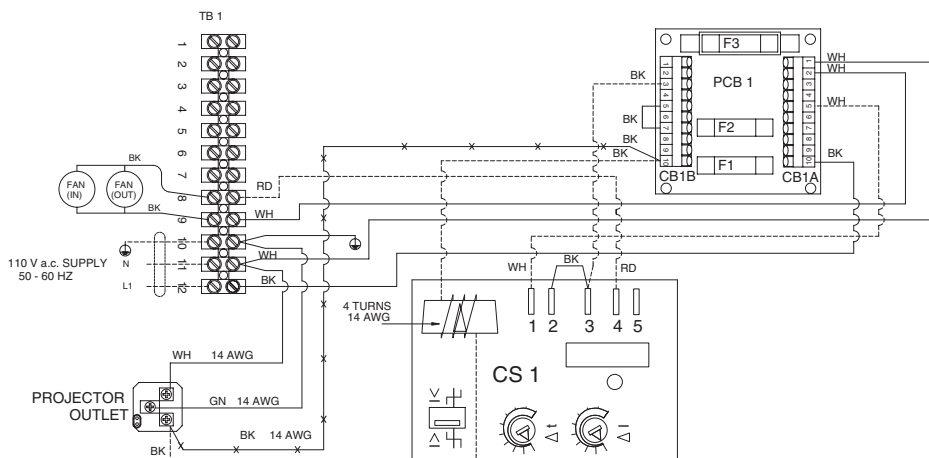

DIAGRAM #1



NOTES:
 1. ✕ ✕ ✕ WIRE TO BE REMOVED BEFORE INSTALLING PLENUM WIRING
 2. ——— WIRES CONNECTED BY INSTALLER
 3. ALL WIRES 18 AWG. UNLESS OTHERWISE SPECIFIED.

PLENUM INSTALLATION PART LIST

ITEM#	DESCRIPTION	QTY
1	INNER PLENUM COVER	1
2	OUTER PLENUM COVER	1
3	INNER END PANEL	1
4	OUTER END PANEL	1
5	INPUT FAN MOUNT ASSEMBLY	1
6	EXHAUST FAN MOUNT ASSEMBLY	1
7	SCREW #10-32 X .375" HEX HD TYPE "F" ZINC	8
8	WASHER, #10 ZINC INTERNAL LOCK	8
9	PRE-WIRED CURRENT SENSOR	1
10	SCREW #6-32 X 1" LONG PHIL PAN HD ZINC	2
11	CLIP ADHESIVE BACKED CORD 1/4" HOLDING DIA.	7
12	39" LONG 1" WIDE X 0.03" THICK NYLON TAPE	1
13	43" LONG 1" WIDE X 0.03" THICK NYLON TAPE	1

TOOLS NEEDED

- MED POINT PHILLIP SCREWDRIVER
- 1/8" FLAT BLADE SCREW DRIVER
- 3/8" WRENCH

Plenum Operating Instructions

The Revelation plenum features a unique design that allows easy access to virtually anywhere inside the unit. Access is achieved by removing either end panel, which, in themselves, feature captive screw assemblies so no hardware can be lost or misplaced. Once the end panel is removed simply slide the plenum housing toward the center of the unit. Service and maintenance is made simpler due the accessibility available through this unique plenum design.

Each plenum also features a ventilation system designed to maintain a suitable operating environment for your projector. An integrated current sensor

in the Revelation circuitry turns on the fans anytime the projector is operating and circulates fresh air through the unit. Two 4" duct flanges are located on the ends of the plenum for installation of duct work for directing the airflow to and from the unit. The input flange is located on the motor/drive end of the Revelation and the exhaust is located at projector end of the revelation. If duct work is attached to the Revelation, follow guidelines in Plenum Installation Instructions on page 6.

Wiring Diagrams for Revelation with Plenum
Single Station Control

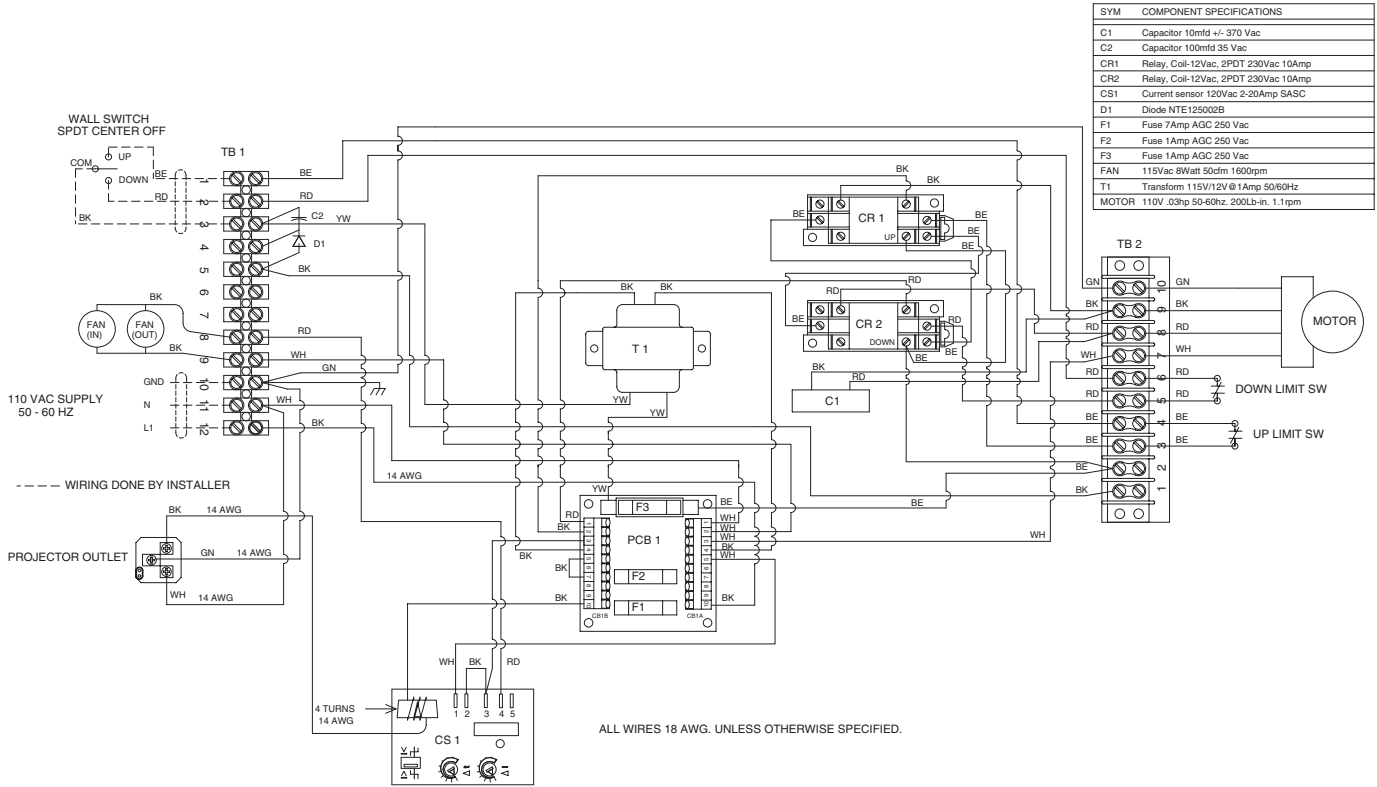

Low Voltage Multiple Station and Remote Control

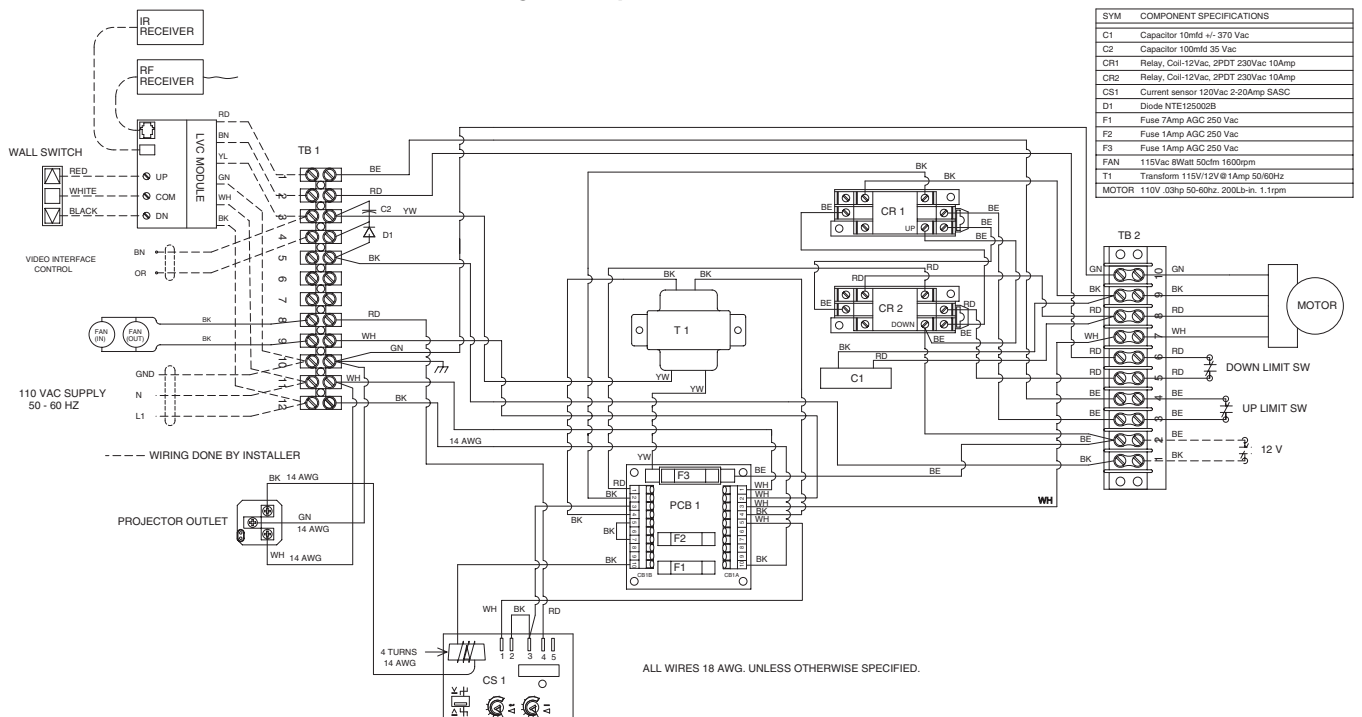

VIC12 Kit Installation Instructions

The VIC 12 KIT includes all the components necessary for the VIC 12 to work with the Revelation. Follow these steps to install the components in this KIT.

- ① Close the door to the Revelation.
- ② DISCONNECT POWER TO THE REVELATION.
- ③ Remove the covers from the electrical enclosure.
- ④ Attach the pre-wired limit switch [1] to the shaft mounting bracket which is closest to the motor as shown in FIGURE #1. Using the #6-32 x 1" [2] long screws and #6 lock washers [2] provided.
- ⑤ Run the wires through the open grommet in the end of the electrical enclosure that is toward the motor as shown in FIGURE #1 and connect them as follows:
 Connect the black wire to screw #1 of TB2
 Connect the blue wire to screw #2 of TB2. (Be sure that wires do not interfere with moving linkage or the sliding inner pan)
- ⑥ Put the 12V ACTUATOR LEVER [3] onto the shaft as shown in Figure #2. The 12V ACTUATOR LEVER will need to be spread out before it will fit onto the shaft. The door to the Revelation must be closed before going on to step #7
- ⑦ Position the 12V ACTUATOR LEVER by rotating it into the limit switch until the limit switch clicks and secure the lever onto the shaft using the #10-32 screw [4] and lock washer [5] supplied with the lever. (Be sure that the screw on the lever is tightened so that the lever does not twist on the shaft.)
- ⑧ After the VIC 12 [7] is installed with the screen, run the wiring to the Revelation using the cord strain relief [6] and connect to TB1 as shown in the Revelation wiring diagram.
- ⑨ Put the covers back on to the electrical enclosure.
- ⑩ Reconnect power to the Revelation.

FIGURE #1

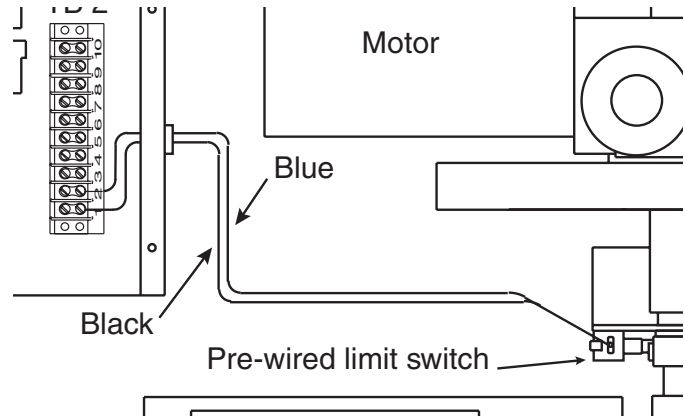
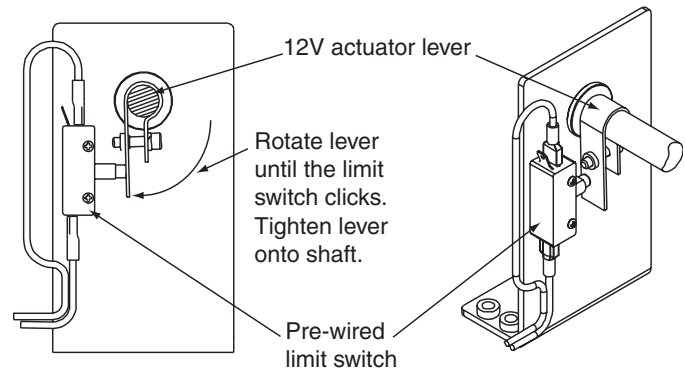

FIGURE #2



VIC 12 OR VIC 12 MODIFIED INSTALLATION PART LIST

ITEM #	DESCRIPTION	QTY
1	PRE-WIRED LIMIT SWITCH	1
2	SCREW #6-32 X 1" LONG PHIL PAN HD W/ EXT LOCK WASHER	2
3	12V ACTUATOR LEVER	1
4	SCREW #10-32 X 3/8" LONG SHCS	1
5	WASHER #10-.190" I.D. X .375" O.D. ZINC INTERNAL TOOTH	1
6	FITTING CORD CRIMP STRAIN RELIEF	1
7	VIC 12 OR VIC 12 MODIFIED	1

TOOLS NEEDED

- MED POINT PHILLIP SCREW DRIVER
- 1/8" FLAT BLADE SCREW DRIVER
- 3/16" ALLEN WRENCH