

## SPECIFICATIONS

### Rolled Classic

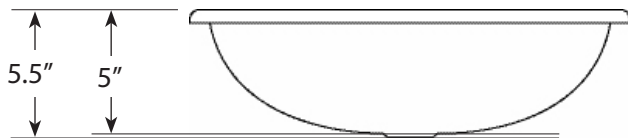
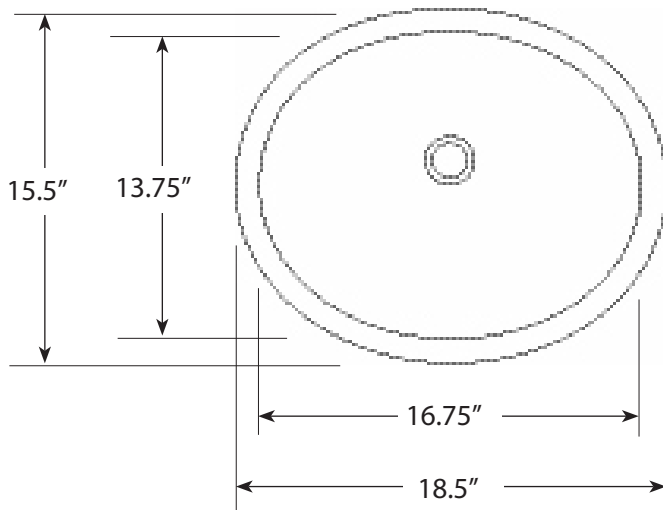

#### FEATURES

- \* 18.5" x 15.5" x 5.5" OD
- \* 16.75" x 13.75" x 5" ID
- \* Hand hammered 18 gauge copper
- \* 1.5" drain opening
- \* Dimensions are not exact and may vary 1/2"

#### FINISHES

- \* Antique - CPS240
- \* Natural - CPS140
- \* Brushed Nickel - CPS540

#### INSTALLATION

- \* Lavatory
- \* Self-rimming

#### COORDINATING ACCESSORIES

- \* Drains: DR120, DR140 or DR160

#### STANDARDS COMPLIANCE

- \* IAPMO Listed / cUPC

#### IMPORTANT

Due to the handcrafted nature of this product, it will vary in finish, texture, hammering, and other details. Dimensions may vary up to 1/2". We strongly recommend that you wait for the actual product before making any installation cuts.