



INSTALLATION, OPERATION AND MAINTENANCE MANUAL

Warning

Please read carefully before proceeding with installation. Your failure to follow any attached instructions or operating parameters may lead to the product's failure.

Save manual for future reference

MODEL WP-4V



System Tested and certified by NSF International against ANSI/NSF Standard 53 & 58 for the reduction of the claims specified on the performance data sheet.

Refer to enclosed warranty and operating parameters to ensure proper use with your water supply.

Watts Premier, Inc.
Phone: 800-752-5582

8716 W Ludlow Drive Suite #1
www.premierH2o.com

Peoria, AZ 85381
Fax: 623-866-5666

Thank you for your purchase of a state of the art Watts Premier Reverse Osmosis (RO) water treatment system. Water quality concerns are becoming more of a focus for the public. You may have heard about contaminants in the drinking water, such as Arsenic, Chromium, Cryptosporidium or Giardia. There may also be some local water issues such as high levels of Lead and Copper. This Watts Premier water treatment system has been designed and tested to provide you with high quality water for years to come. The following is a brief overview of the system.

Your Reverse Osmosis System:

Osmosis is the process of water passing through a semi permeable membrane in order to balance the concentration of contaminants on each side of the membrane. A semi permeable membrane is a barrier that will pass some particles like clean water, but not other particles like arsenic and lead.

Reverse osmosis uses a semi permeable membrane; however, by applying pressure across the membrane, it concentrates contaminants (like a strainer) on one side of the membrane, producing clean water on the other. This is why RO systems produce both clean drinking water and waste water that is flushed from the system. This reverse osmosis system also utilizes carbon block filtration technology, and can therefore provide much higher quality drinking water than carbon filtration systems.

Your system is a Four Stage RO which is based upon four separate treatment segments within one complete water filtration system. These stages are as follows:

Stage 1 – Sediment filter, recommended change 6 months.

The first stage of your RO system is a five micron sediment filter that traps sediment and other particulate matter like dirt, silt and rust which affect the taste and appearance of your water.

Stage 2 – Carbon filter, recommended change 6 months.

The second stage contains a 5 micron carbon block filter. This helps ensure that chlorine and other materials that cause bad taste and odor are greatly reduced.

Stage 3- Membrane, recommended change 2-5 years.

Stage three is the heart of the reverse osmosis system, the RO membrane. This semi-permeable membrane will take out TDS & Sodium and a wide range of contaminants such as Perchlorate, Chromium, Arsenic, Copper, Lead, as well as Cysts, such as Giardia and Cryptosporidium and much more. Because the process of extracting this high quality drinking water takes time, your RO water treatment system is equipped with a storage tank.

Stage 4- VOC Block, recommend change 12 months.

Watts Premier WP-4V reverse osmosis system conforms to NSF/ANSI 58 for VOC reduction. Through the specialty formulated VOC post filter your system is capable of reducing harmful Volatile Organic Chemicals (VOC) like MTBE's, Atrazine, Benzene, 2,4-D, Lindane and others from your drinking water. It is estimated that VOC's are present in one-fifth of the nation's water supplies. These water contaminants can enter ground water from a variety of sources including localized use of herbicides and pesticides, gasoline or oil spills, leaking underground fuel tanks, septic system cleaners, and chemicals used in the dry-cleaning industry. See performance data sheet for individual contaminants and reduction performance.

Note: Filter life may vary based upon local water conditions and/or use patterns.

System Maintenance

Just because you can not taste it, does not mean that it is not there. Contaminants such as lead, chromium, VOC's and arsenic are undetectable to the taste. Additionally, over time if you do not replace the filter elements, other bad tastes and odors will be apparent in your drinking water.

This is why it is important to change out your filter at the recommended intervals as indicated in this system manual. When replacing the filter elements, pay special attention to any cleaning instructions. Should you have any further questions please refer to our website at www.premierH2o.com or call our customer service dept. at **1-800-752-5582**.

**** Before installation, please take a moment to fill out the warranty card on page 25.**

With proper installation and maintenance, this system will provide you with high quality water for years to come. All of Watts Premier's water enhancement products are rigorously tested by independent laboratories for safety and reliability. If you have any questions or concerns, please contact our customer service department at 1-800-752-5582 (outside USA 480-675-7995) or refer to our on-line trouble shooting section at www.premierH2o.com.

Table of Contents

Operational Parameters	4
Contents of Reverse Osmosis System.....	4
Tools Recommended For Installation	4
Drill a Hole for the Faucet in a Porcelain Sink.....	5
Punch a Hole for the Faucet in a Stainless Steel Sink	5
Watts Faucet Installation	6
Adapt-a-Valve Installation (Plastic / Brass)	7
Drain Saddle Installation	7
Drain Saddle Installation Continued	8
3/8" Black Drain Tube Connection	8
Green Tube Connection	8
Reverse Osmosis Module Mounting	9
Tank Elbow Installation	9
Blue Tube Connection (From unit to tank)	9
How to use Quick Connect Fittings.....	10
Red Tube Connection (From Faucet).....	10
Blue Tube Connection (From Faucet)	10
Start up Instructions.....	11
6 Month Maintenance.....	12
Annual Maintenance.....	13
Membrane Replacement	14
Checking Air Pressure in the Tank	15
Procedure for Extended Non-Use	15
Trouble Shooting	16
Arsenic Fact Sheet.	17
California Certification	18
Performance Data Sheets	19
VOC Performance Data Sheet.....	20
Unit Drawing.....	21
Parts List	21
Other Products	22 - 24
Warranty Registration.....	25 & 26
Service Record	27
Limited Warranty	28

Operational Parameters

Installation must comply with state and local plumbing regulations. This system is intended to be installed on the cold water line only.

Operating Temperatures:	Maximum 100°F (37.8°C)	Minimum 40°F (4.4°C)
Operating Pressure:	Maximum 85 psi (6.0 kg/cm ²)	Minimum 40 psi (2.80 kg/cm ²)
pH Parameters:	Maximum 11	Minimum 2
Iron:	Maximum 0.2 ppm	
TDS (Total Dissolved Solids)	< 1800 ppm	
Turbidity	< 5 NTU	

Hardness: Recommended hardness not to exceed 10 grains per gallon, or 170ppm. System will operate with hardness over 10 grains but the membrane life may be shortened. Addition of a water softener may lengthen the membrane life.

Water Pressure: The operating water pressure in your home should be tested over a 24 hour period to attain the maximum pressure. If the incoming water pressure is above 85 psi a pressure regulator is recommended and if over 100 psi then a pressure regulator is required. Should you need a gauge to check your water pressure, see page 19 (item no. 261003).

Copper Tubing: Reverse Osmosis water should not be run through copper tubing as the purity of the water will leach copper causing an objectional taste in water and pin holes may form in the tubing. Watts Premier supplies speciality filters (part number 107008) that can be used if copper tubing follows the Reverse Osmosis unit. Be sure to follow any state or local regulations during installation.

Contents of Reverse Osmosis (RO) System

- 1 Tank – White
- 1 Module – White
- 1 Parts Bag
- 1 Faucet Bag
- 1 Filter Wrench
- 1 Manual

If any of the items are missing please contact Watts Premier prior to installing.



*** All Filters Are Pre-Installed**

Tools Recommended For Installation

- √ 1 1/4" Hole Saw Bit for Faucet opening and/or
- √ Round Knock out Punch for Stainless Sinks 1 1/4"
- √ Adjustable Wrench
- √ Sharp Knife
- √ 1/2" - 13/16" Open End Wrenches
- √ Phillips Screw Driver
- √ Needle Nose Pliers – Adjustable Pliers
- √ Electric Drill
- √ 1/8", 1/4" & 3/8" Drill Bits



Drill a Hole for the Faucet in a Porcelain Sink

Note: *Most sinks are pre drilled with 1 ½” or 1 ¼” diameter hole that you can use for your RO faucet. (If you are already using it for a sprayer or soap dispenser, see step 1)*

Porcelain sinks are extremely hard and can crack or chip easily. Use extreme caution when drilling. Watts Premier accepts no responsibility for damage resulting from the installation of faucet.

Step 1 Determine desired location for the RO faucet on your sink and place a piece of masking tape on over where the hole is to be drilled. Mark the center of the hole on the tape.

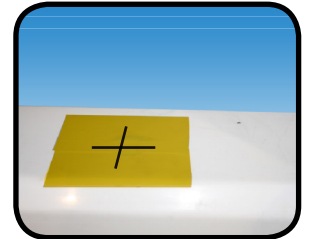

Step 2 Using a variable speed drill set on the slowest speed, drill a 1/8” pilot hole through both porcelain and metal casing of sink at the marked center of the desired location. Use lubricating oil or liquid soap to keep the drill bit cool (If drill bit gets hot it may cause the porcelain to crack or chip).



Step 3 Using a 1 ¼” hole saw, proceed to drill the large hole. Keep drill speed on the slowest speed and use lubricating oil or liquid soap to keep the hole saw cool during cutting.

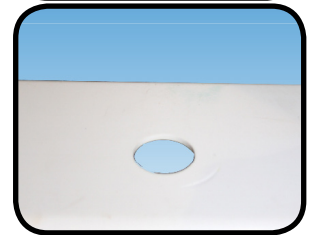

Step 4 Make sure the surroundings of the sink are cooled before mounting the faucet to the sink after drilling and remove all sharp edges.

Punch a Hole for the Faucet in a Stainless Steel Sink

Note: *If mounting faucet to a Stainless Steel Sink you will need a 1 ¼” Hole Punch. The faucet opening should be centered between the back splash and the edge of the sink, ideally on the same side as the vertical drain pipe.*

Step 5 Drill a ¼” pilot hole. Use a 1/2” Hole Punch and an adjustable wrench to punch the hole in the sink. Change to the 1 ¼” Hole Punch to enlarge the hole.



The faucet can now be installed.

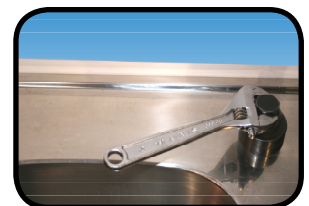

WATTS Premier Monitored (Top Mount) Faucet Installation

A) Connect tubes to the RO faucet (Figure A)

This RO faucet is equipped with quick connect fittings for easy tube installation. To connect tubes, simply push them *firmly* into their corresponding fitting on the RO faucet until fully seated.

Approximately 3/4" of the tube should go into the fitting.

1. Connect 3/8" **BLUE** tube. (3/8" Fitting on Toggle Bolt)
2. Connect 3/8" **BLACK** tube. (3/8" Fitting on base of faucet)
3. Connect 1/4" **RED** tube. (1/4" Fitting on base of faucet)

To disconnect a tube, push in collet (**Fig. b**) squarely against face of fitting (**Fig. a**). With collet held in this position the tube can be removed.

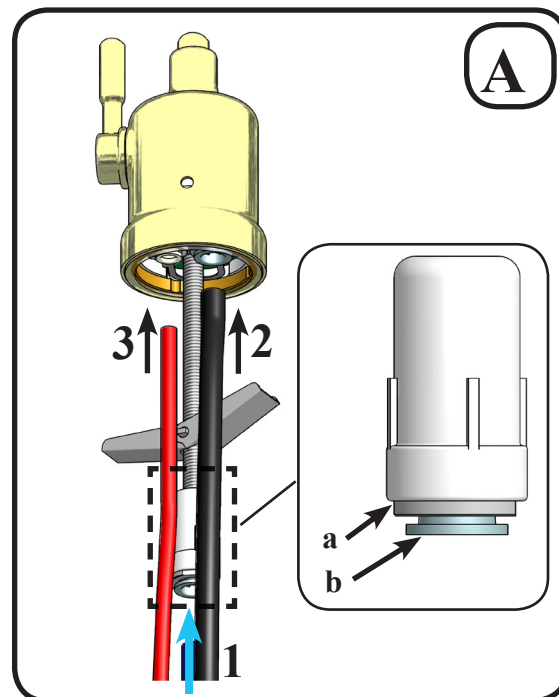

B) Mount the RO faucet (Figure B)

A 1.0" - 1.25" Mounting hole is required for faucet installation.

4. Feed the toggle bolt and tubes through the mounting hole in The sink. Test fit faucet placement.
5. Peel the white backing paper off the seal on the bottom of the faucet base and press firmly over the mounting location.
6. Using a flat head screwdriver torque the toggle bolt through the spout hole to approximately 5lbs/in.

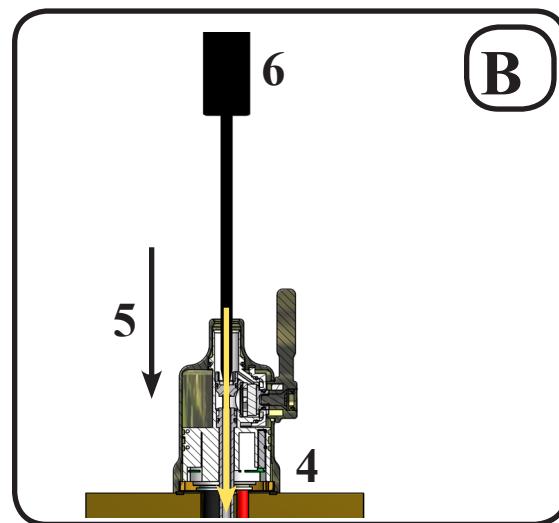

C) Pull Battery Tab and Install Spout (Figure C)

7. Insert spout into the faucet base until fully seated.
8. Pull the Battery Safety Tab out to activate faucet monitor. Make sure that the clear drawer is firmly seated in the faucet base. The monitor will flash briefly once activated.

CAUTION!

“This product contains a button cell battery. If swallowed, it could cause severe injury or death in just 2 hours. Seek medical attention immediately.”

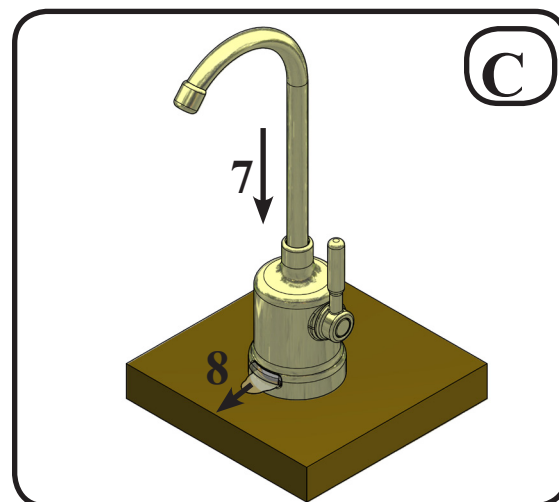

Adapt-a-Valve Installation

Caution: Water supply line to the system must be from the cold water supply line only. Hot water will severely damage your system.

Plastic Valve Configuration:

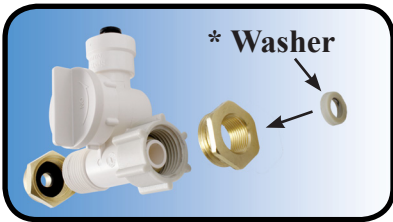

Configuration for 3/8"
(With Brass Fittings)
* Insert White Washer



Hot Supply Cold Supply



Configuration for 1/2"
(Without Brass Fittings)

Brass Valve Configuration:

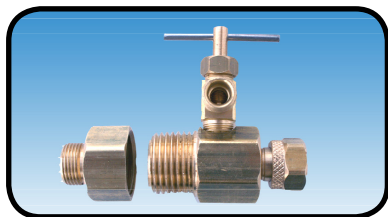

Configuration for 3/8"
compression fittings

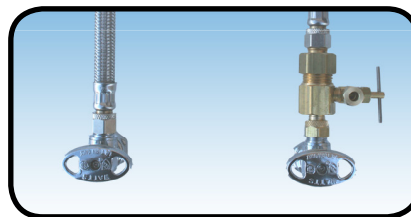

Hot Supply Cold Supply

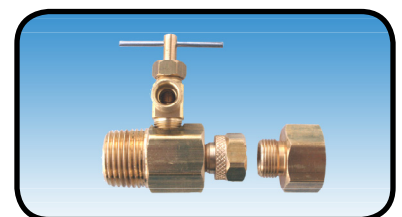

Configuration for 1/2"
compression fittings

- Step 6 Turn off the cold water supply to the faucet by turning the angle stop valve completely off.
- Step 7 Attach the adapt-a-valve as illustrated in the three photos above, choosing the configuration that fits your plumbing.

Drain Saddle Installation - Part# 164016

Drain Saddle fits standard 1 1/4" – 1 1/2" drain pipes

Caution: If you have a garbage disposal, do not install the drain saddle near it. Installation of the drain saddle must be either above the garbage disposal, or if a second sink drain is available, install it above the cross bar on the second drain. Installation of the drain saddle near a garbage disposal may cause the drain line to plug. If no other installation of drain line is available, Watts Premier offers drain line installation kit (part number 164020) that can be used with garbage disposals.

- Step 8 Gather the pieces of the drain saddle:
- | | |
|-------------------------|-----------------------------------|
| 1 Black compression nut | 1 Semicircle bracket with opening |
| 2 Screws | 1 Foam gasket |
| 2 Nuts for screws | 1 Semicircle bracket |

- Step 9 The small square black foam gasket with a circle cut out of the middle must be applied to the inside of the drain saddle. Remove sticky tape backing and stick to the drain saddle as shown.

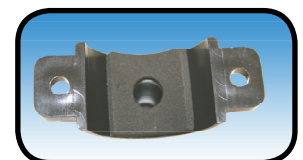
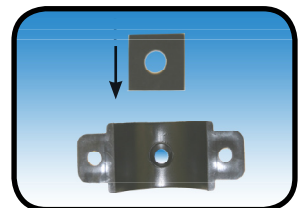
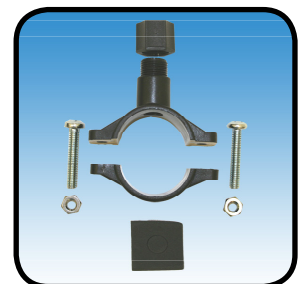

Drain Saddle Installation Continued...

- Step 10 The drain saddle must be mounted at least 1 ½" above the nut of the P-trap or cross bar from the garbage disposal to insure proper drainage. Assemble the drain saddle around the drain pipe at the best available location. Using Phillips screw driver tighten screws evenly and securely on both sides of the drain saddle. Keep the plastic compression nut off at this time.



Caution: Do not over tighten the screws. It may crack the drain saddle.

Drill Hole and Connect 3/8" Black Tube from Faucet to the Drain

IMPORTANT:

The black 3/8" drain tube must be as SHORT and STRAIGHT as possible to the drain saddle, making a downward slope from faucet to drain saddle to allow for proper drainage. This is a gravity fed line and if there is any bend or dip in the tube, the rinse water will not flow into the drain properly. Water may back up and come out the air gap hole in the back of the faucet.

- Step 11 With the drain saddle secured onto the drain pipe, using a 1/4" drill bit installed in your electric drill, insert the drill bit through the opening in the drain saddle and drill through the drain pipe.



Caution: It is very important to keep the drill centered to prevent damage of the drain saddle while drilling.

- Step 12 Measure the 3/8" black tube from faucet to the drain saddle on the drain pipe and make a straight cut to the correct length.

- Step 13 Slip black tube through black compression nut. Insert black tube into the opening in the drain saddle and hand tighten the black nut, and add 1/4 turn with a wrench.

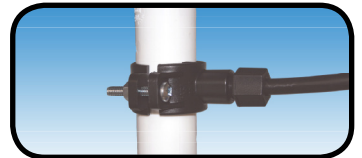

Green Tube Connection

Brass Valve:

- Step 14 Locate green tube attached to the RO Module. Remove a brass nut, plastic sleeve and brass insert from the parts bag. To assemble, place the brass nut on the green tube first, then the sleeve (small tapered end of sleeve must point to the end of tube) and then push the brass insert all the way into the end of the tube. (See Picture)

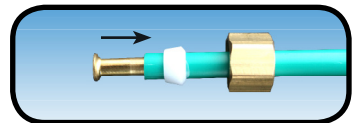

- Step 15 Insert the green tube into the 1/4" opening on the adapt-a-valve until it stops. Slide the brass nut and sleeve down and thread onto the male pipe threads. Use a 1/2" wrench to securely tighten the nut.

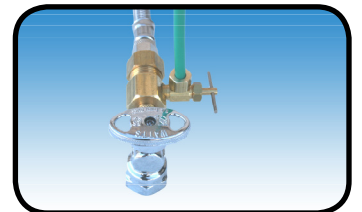

Plastic Valve Valve:

- Step 16 Locate green tube attached to the RO Module. Insert the open end of the green 1/4" tube into the open 1/4" quick connect fitting on the plastic water feed valve making sure the tube is pushed in all the way to the tube stop.

Reverse Osmosis Module Mounting

Step 17 Determine best location for the RO module to be mounted to allow for future system maintenance. The parts bag has 2 self tapping screws. Using an electric drill with a Phillips bit, screw them into the cabinet wall 6" apart and 16" from the bottom of the cabinet.



Tank Elbow Installation

Step 18 Wrap (7 to 12 turns) of teflon tape clockwise around the male pipe threads (MPT) on the Stainless Steel fitting on top of the tank.

Note: *Do not let the tape cover the opening.*



Step 19 Thread the plastic elbow (supplied in the parts bag) onto the stainless steel connection on the top of tank. Tighten using an adjustable wrench. **Do not over tighten as plastic could crack.**



Connect Blue Tube from "TANK" Port on RO Module to the Tank

Step 20 Position tank in desired location. Stand it upright or lay it on its side (using the black plastic stand). Measure the blue tube from the RO module port marked "TANK" over to the tank and cut it to desired length.



Step 21 Insert the blue 3/8" tube into the compression side of the elbow previously installed on top of the storage tank and push in as far as it will go. Tighten the compression nut securely with a wrench.



How To Use the Quick Connect Fittings on the RO Module

To make a connection, the tube is simply pushed into the fitting. The unique patented John Guest® locking system holds the tube firmly in place without deforming it or restricting flow.

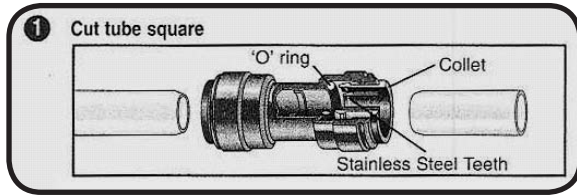

It is essential that the outside diameter be free of score marks and that burrs and sharp edges be removed before inserting into fitting.

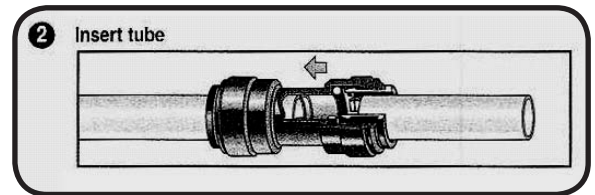

Fitting grips before it seals. Ensure tube is pushed into the tube stop.

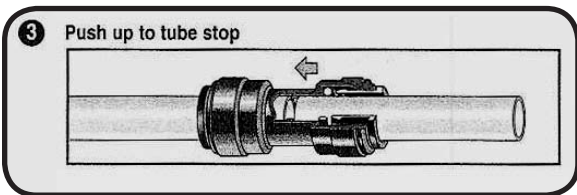

Push the tube into the fitting, to the tube stop. The collet (gripper) has stainless steel teeth which hold the tube firmly in position while the O-ring provides a permanent leak proof seal.

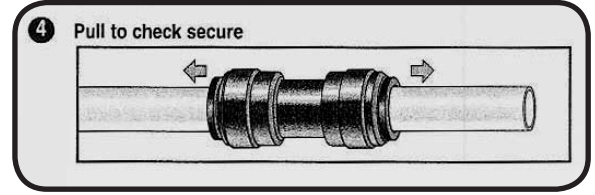

Pull on the tube to check that it is secure. It is a good practice to test the system prior to leaving site and /or before use.

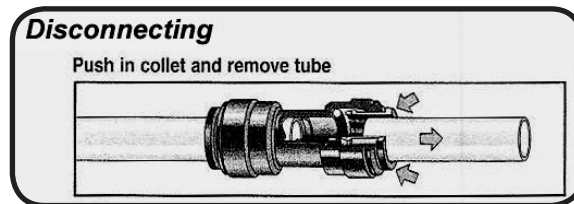

To disconnect, ensure the system is depressurized before removing the tube. Push in collet squarely against face of fitting. With the collet held in this position, the tube can be removed. The fitting can then be reused.

Connect the Red Tube from Faucet to RO Module

Step 22 Insert the open end of the red 1/4" tube attached to the RO faucet into the 1/4" X 1/4" quick connect fitting on the RO Manifold. Make sure the tube is pushed in all the way to the tube stop. (See Picture)

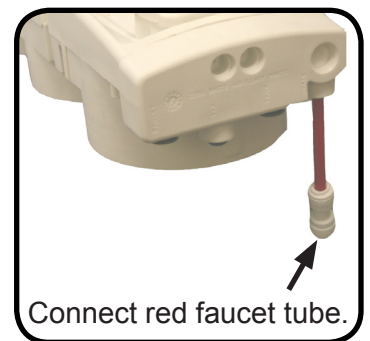

Connect the Blue Tube from the Faucet to RO Module

Step 23 Insert the blue 3/8" tube from the faucet into the port on the module marked "FAUCET". Make sure the tube is pushed in all the way to the tube stop.

Note: A connection to a refrigerator / ice maker may be tee'd into this blue tube. Watts Premier offers an ice maker install kit part # 500102 (See Page 22).

Congratulations!

You have completed the installation of new your Reverse Osmosis system.

Please Follow the Startup Instructions.

Start up Instructions

Step 1 Turn on the incoming cold water at the angle stop valve. Open the needle valve on the brass Adapt-a-Valve by turning counter clockwise. Check the system for leaks and tighten any fitting as necessary. (Check frequently over the next 24 hours to ensure no leaks are present).

Step 2 If you have connected your RO system to a refrigerator / ice maker, make sure the ice maker is off (do not allow water to flow to the ice maker) until flushing (Step 5) is complete and the tank has been allowed to completely fill. Connection from the RO to the ice maker system should have an in-line valve installed before the ice maker so it can easily be closed to prevent water flowing to the ice maker during start up and periodic maintenance. Your RO tank must be allowed to fill up fully in order for the ice maker system to work properly.

Step 3 Open the RO faucet and leave it open until water begins to trickle out (it will come out slowly).

Step 4 Close the RO faucet allowing the storage tank to fill with water. It may take 4 to 6 hours to fill the tank completely depending on the production capability of the membrane, local water temperature and water pressure.

Note: ***During the fill period you may hear water trickling due to the Reverse Osmosis Process.***

Step 5 After the Tank has filled, open the RO Faucet to flush the tank completely. You will know that the tank is empty when the flow rate from the RO faucet is down to a trickle. Repeat this step two more times. The fourth tank can be used for drinking.

The flushing process should take about a day to complete.

Note: ***Flushing of the tank 3 times is only necessary during the initial startup and after replacing the membrane.***

Don't Forget To Register!

Register by mail, phone, fax or internet. Watts Premier uses this information only to provide a filter change reminder notice. Pre-filters should be changed every 6 months and VOC filter annually. You may register your system via our website at www.premierH2o.com or call 1-800-752-5582 (within USA only) / FAX#: 623-866-5666.

For Warranty card Please see page 25-26.

6 Month System Maintenance

*Order filters by calling 1-800-752-5582 or buy online at www.premierH2o.com.

√ Stage 1 - Sediment Filter (part #: 104017)

√ Stage 2 - Carbon Block Filter (part #: 101009-White End Caps)

Step 1 Turn off the incoming water supply to the RO by turning the needle valve on the adapt-a-valve clockwise until it stops. (Follow the green tube away from the RO system to find the adapt-a-valve.)

Step 2 Open the RO Faucet and allow water to drain from the tank until it is completely empty.

Note: *Water Can be saved in a container for drinking or to rinse system parts.*

Step 3 Let system sit for a few minutes after tank is empty to depressurize before attempting to remove filter housings.

Step 4 For more leverage you may leave the RO module attached to wall of cabinet. If you are unable to access the module while it hangs, remove it prior to changing filters. Starting with the closest housing (Stage 1), remove it by turning it clockwise, empty water, then discard filter. Continue on to the 2nd housing (Stage 2).

Step 5 Clean filter housings (bowls) with a mild soap solution and rinse with water. Check O-rings and lubricate with water soluble lubricant. *KY Jelly® or other water based lubricants may be used. Petroleum based lubricants (such as Vaseline®) must not be used.*

Caution: *Before re-installing the filter bowls back on to the system , check O-rings to make sure they are still in place.*

Step 6 Insert the new sediment filter (cloth like appearance) into the 1st filter housing which is the one closest to the side with tubing connections and re-install housing.

Step 7 Insert the new Carbon Block filter (White End Caps) into the middle housing and re-install housing.

Step 8 Turn water on to the unit by turning the needle valve on the adapt-a-valve counter clock wise.

Step 9 Open the RO faucet and leave it open until water begins to trickle out (it will come out slowly).

Step 10 Close the RO faucet allowing the storage tank to fill with water. It may take 4 to 6 hours to fill the tank completely depending on the production capability of the membrane, local water temperature and water pressure.

Note: *** To reset the electronic monitor during replacement of filters, simply slide out the battery from the base of the faucet and reinsert.*

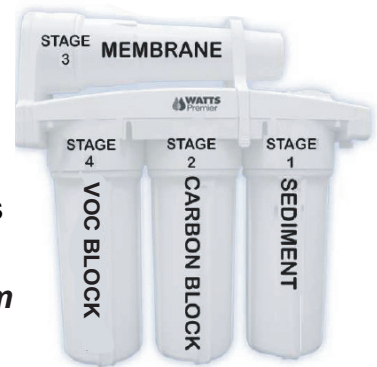

Annual Maintenance

*Order filters by calling 1-800-752-5582 or buy online at www.premierH2o.com.

- √ Stage 1 - Sediment Filter (part #: 104017)
- √ Stage 2 - Carbon Block Filter (part #: 101009-White end caps)
- √ Stage 4 - VOC Carbon Block (part #: 101013-Blue end caps)
- √ 1/2 Cup of hydrogen peroxide or 2 tablespoons of common household bleach.

Note: *Sanitizing of unit is recommended.*

- Step 1 Perform steps 1 through 3 in the Six Month System Maintenance (Page 12).
- Step 2 For more leverage you may leave the RO module attached to wall of cabinet. If you are unable to access the module while it hangs, remove it prior to changing filters. Starting with the closest housing (Stage 1), remove it by turning it clockwise, empty water, then discard filter. Continue on to the 2nd (Stage 2) and 3rd (Stage 4) housings.

Note: *If not sanitizing the system skip to step 9.*

- Step 3 Open the horizontal membrane housing and remove the RO membrane. Rest the membrane in a clean, sanitary place. Replace the empty membrane housing onto the unit.
- Step 4 Leaving the filters out, replace stage 2 and 4 empty filter housings (hand tight) onto unit. Measure & pour either 1/2 cup of hydrogen peroxide or 2 tablespoons of common household bleach into the 1st filter housing (Stage 1) and hand tighten onto unit.
- Step 5 Turn on incoming water supply to the system by turning the adapt-a-valve counter clockwise. Wait 1 minute for the unit to pressurize. Turn on the RO faucet and let the water run for 30 seconds. Turn off the RO faucet and let the unit rest for 2 minutes. Finally, open the RO faucet and let the water run for 5 more minutes.
- Step 6 Turn off the incoming water supply to the system by turning the adapt-a-valve clockwise until it stops. Keep the RO faucet open until the storage tank is completely drained.
- Step 7 Open the membrane vessel and insert the RO membrane back into the manifold while making sure not to kink the O-rings. Tighten the membrane housing back on the RO unit (Refer to "Membrane Replacement" below for details).
- Step 8 Remove filter housings Stage 1, 2 and 4 and empty of water.

Caution: *Before re-installing the filter bowls back on to the system , check O-rings to make sure they are still in place and lubricate with water soluble lubricant.*

- Step 9 Insert the new sediment filter (cloth like appearance) into the 1st filter housing which is the one closest to the side with tubing connections and re-install housing.
- Step 10 Insert the new Carbon Block filter (White End Caps) into the middle housing and re-install housing.
- Step 11 Insert the new VOC Carbon Block filter (Blue End Caps) into the 3rd filter housing which is the one farthest from the side with tubing connections and re-install housing.

Tip: *This is a good time to check the air pressure in your storage tank. For instructions please see page 15.*

- Step 12 Follow Steps 8 through 10 in the Six Month System Maintenance (Page 12) for startup directions.

This reverse osmosis system contains a replaceable component (the RO membrane) which is critical to the efficiency of the system. Replacement of this reverse osmosis membrane should be with one of identical specifications as defined by Watts Premier to assure the same efficiency and contaminant reduction performance.

Membrane Replacement

Membranes have a life expectancy between 2 and 5 years, depending on the incoming water conditions and the amount the RO system is used. This reverse osmosis membrane is critical for effective reduction of total dissolved solids (TDS). The product water should be tested periodically to verify that the system is performing satisfactorily.

Normally, a membrane would be replaced during a semiannual or annual filter change. However, if at any time you notice a reduction in water production or an unpleasant taste in the reverse osmosis water, it could be time to replace the membrane. Watts Premier recommends replacing the membrane when TDS reduction falls below 75%.

Note: *A water sample may be sent to Watts Premier for a free diagnosis of your membranes performance. To send a water sample, use two (2) clean containers and fill ½ cup of tap water in one container and ½ cup of reverse osmosis water in 2nd container. Clearly label each sample. Send the samples to the address listed on the cover of this manual attention "Water Samples". Watts Premier will test the water and mail or call you with the results.*

Step 1 Turn off the incoming water supply to the RO by turning the needle valve on the adapt-a-valve clockwise until it stops. (Follow the green tube away from the RO system to find the adapt-a-valve.)

Step 2 Open the RO Faucet and allow water to drain from the tank until it is completely empty.

Step 3 Remove the horizontal membrane housing on top of the unit by turning it counter clockwise to loosen.

Step 4 Pull firmly on the yellow RO membrane to remove it from the housing and discard.

Step 5 Lubricate the O-rings on the new membrane with a water soluble lubricant such as KY Jelly ®. Insert the end with the two black O-rings into the cap. Twist the membrane as you push it firmly into the manifold.

Caution: *Before re-installing the membrane housing back on to the system, check O-ring on the housing to make it is still in place and lubricate with water soluble lubricant.*

Step 6 Replace the membrane housing onto the cap by turning clockwise. Tighten securely.

Step 7 Follow Start up instructions on page 11.

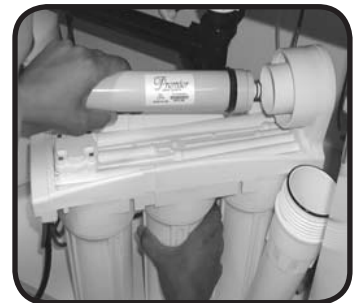
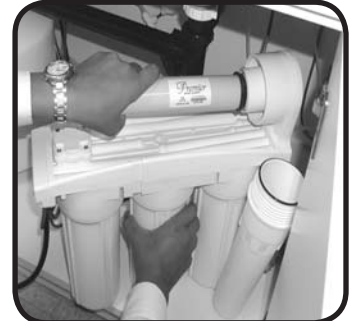

Check Air Pressure in the Tank

Important: *Check air pressure only when tank is empty of water!*

Check air pressure in the storage tank when you notice a decrease in available water from the RO system. Air can be added with a bicycle pump using the schrader valve that is located on the lower side of the tank behind a blue plastic cap.

Step 1 Turn off the incoming water supply to the RO by turning the needle valve on the adapt-a-valve clockwise until it stops. (Follow the green tube away from the RO system to find the adapt-a-valve.)

Step 2 Open the RO Faucet and allow water to drain from the tank until it is completely empty.



Tip: *When water from the RO faucet slows to a trickle, with the faucet still in the open position, you may add air to the tank to purge any left over water, this will ensure that the tank is completely empty.*

Step 3 Once all water in the tank is purged, check air pressure using an air pressure gauge, it should read between 5 - 7 PSI. (Digital air pressure gauge is recommended)

Procedure for Extended Non-Use (More than 2 months)

Turn off the water supply by turning the “T” on the adapt-a-valve clockwise until it stops and open the RO faucet to empty the storage tank (Save a few ounces of RO water). Once the storage tank is empty, remove the membrane and place it in a sealed plastic bag with the RO water saved earlier and store in your refrigerator.

For restart, reinstall membrane and follow startup procedure on page 11.

TROUBLE SHOOTING

Problem	Cause	Solution
1. Low/Slow Production	Low Water Pressure	Assure a minimum of 40 psi incoming water pressure. Premier sells a booster pump if home water pressure is low. Make sure water supply is turned on and Adapt Valve is all the way open
	Crimps in tubing	Check tubing and straighten or replace as necessary.
	Clogged pre-filters Fouled membrane	Replace pre-filters. Replace membrane and clean flow restrictor.
2. Milky colored Water	Air in system	Air in the system is a normal occurrence with initial start up of the RO system. This milky look will disappear during normal use within 1-2 weeks. If condition reoccurs after filter change, drain tank 1 to 2 times.
3. Water constantly running/unit will not shut off	Low water pressure	See #1 Above
	Fouled membrane High water pressure	Replace membrane Check incoming water pressure to make sure it does not exceed 100psi. A pressure relief valve may be necessary.
	High air pressure in tank	Empty storage tank of water. Set tank air pressure to 5 psi. See Page 15.
4. Noise from faucet or drain	Air gap faucet	Inherent sound with air-gap faucets.
	Location of drain saddle	See diagram for proper location of drain saddle.
	Higher capacity membrane	Normal with high capacity membrane
	High water pressure	Check incoming water pressure to make sure it does not exceed 100 psi. A pressure relief valve may be necessary.
5. Faucet leaks from the air gap feature	Crimp or loop in drain line Drain tube clogged/restricted	Straighten black 3/8 drain tube. Cut off any excess tubing Caused from dishwasher or garbage disposal. Disconnect the 3/8" black tube at the drain, clean the 3/8" black tube out with a wire, then reconnect.
6. Small amount of water in storage tank	System just starting up	Normally it takes 4-6 hours to fill tank. Note: Low water pressure and/or temperature can drastically reduce production rate.
	Low water pressure	See #1 Above
	Too much air in tank	Add air if below 5 psi and bleed if above 5 psi. Check only when tank is empty of water. See Page 15.
7. Water leaks from the filter housing	Not properly tightened. Missing or kinked O-ring	Tighten the bowl Turn off the water supply. Release the pressure, remove bowl and replace the O-ring. (p/n 113043). Make sure the O-ring is seated in the filter bowl properly before reinstalling the filter bowl.

Arsenic Fact Sheet

Arsenic (As) is a naturally occurring contaminant found in many ground waters. Arsenic in water has no color, taste or odor. It must be measured by an arsenic test kit or lab test.

Public water utilities must have their water tested for arsenic. You can obtain the results from your water utility contained with in your consumer confidence report. If you have your own well, you will need to have the water evaluated. The local health department or the state environmental health agency can provide a list of test kits or certified labs.

There are two forms of arsenic: pentavalent arsenic (also called As (V), As (+5)) and trivalent arsenic (also called As (III), As (+3)). In well water, arsenic may be pentavalent, trivalent, or a combination of both. Although both forms of arsenic are potentially hazardous to your health, trivalent arsenic is considered more harmful than pentavalent arsenic.

RO systems are very effective at removing pentavalent arsenic. A free chlorine residual will rapidly convert trivalent arsenic to pentavalent arsenic. Other water treatment chemicals such as ozone and potassium permanganate will also change trivalent arsenic to pentavalent arsenic. A combined chlorine residual (also called chloramine) where it does convert trivalent arsenic to pentavalent arsenic, may not convert all the trivalent arsenic in to pentavalent arsenic. If you get your water from a public water utility, contact the utility to find out if free chlorine or combined chlorine is used in the water system.

This Watts Premier reverse osmosis system is designed to remove up to 98% of pentavalent arsenic. It will not convert trivalent arsenic to pentavalent arsenic. Under laboratory standard testing conditions, this system reduced 0.30 mg/L (ppm) pentavalent arsenic to under 0.010 mg/L (ppm) (the USEPA standard for drinking water). Actual performance of the system may vary depending on specific water quality conditions at the consumer's installation. In addition to the independent laboratory standard testing conditions Watts Premier has conducted additional field testing on our reverse osmosis units to determine trivalent arsenic reduction capabilities. Based upon Watts Premier field testing, it has been determined that the RO units are capable of reducing up to 67% of trivalent arsenic from the drinking water.

The RO membrane component of this Watts Premier reverse osmosis system must be maintained according to its recommended maintenance cycle. Specific component identification and ordering information can be found in the installation/operation manual maintenance section, by phone at 1-800-752-5582 or online www.premierH2o.com

State of California
 Department of Health Services
 Water Treatment Device
 Certificate Number
 05 - 1731

Date Issued: November 9, 2005

Trademark/Model Designation

WP-4v

Replacement Element(s)

sediment prefilter: 104017
 carbon prefilter: 101009
 membrane: 110016
 post filter: 101013

Manufacturer: Watts Premier

The water treatment device(s) listed on this certificate have met the testing requirements pursuant to Section 116830 of the Health and Safety Code for the following health related contaminants:

Microbiological Contaminants and Turbidity

Cysts

Inorganic/Radiological Contaminants

Arsenic¹ (pentavalent)
 Barium
 Cadmium
 Chromium (hexavalent)
 Chromium (trivalent)
 Copper
 Fluoride
 Lead
 Radium 226/228
 Selenium
 Perchlorate ($\leq 100 \mu\text{g/L}$)²

Organic Contaminants

VOCs

Alachlor
 Atrazine
 Benzene
 Carbofuran
 Carbon Tetrachloride
 Chlorobenzene
 Chloropicrin
 2,4-D
 DBCP
 o-Dichlorobenzene
 p-Dichlorobenzene
 1,2-Dichloroethane
 1,1-Dichloroethylene
 cis-1,2-Dichloroethylene
 trans-1,2-Dichloroethylene
 1,2-Dichloropropane
 cis-1,3-Dichloropropylene
 Dinoseb

Endrin
 Ethylbenzene
 EDB
 Haloacetonitriles (HAN)
 Bromochloroacetonitrile
 Dibromoacetonitrile
 Dichloroacetonitrile
 Trichloroacetonitrile
 Haloketones (HK)
 1,1-Dichloro-2-Propanone
 1,1,1-Trichloro-2-Propanone
 Heptachlor
 Heptachlor Epoxide
 Hexachlorobutadiene
 Hexachlorocyclopentadiene
 Lindane
 Methoxychlor
 Pentachlorophenol

Simazine
 Styrene
 1,1,2,2-Tetrachloroethane
 Tetrachloroethylene
 Toluene
 2,4,5-TP (Silvex)
 Tribromoacetic Acid
 1,2,4-Trichlorobenzene
 1,1,1-Trichloroethane
 1,1,2-Trichloroethane
 Trichloroethylene
 Trihalomethanes (THMs)
 Bromodichloromethane
 Bromoform
 Chloroform
 Chlorodibromomethane
 Xylenes

Rated Service Capacity: 600 gals

Rated Service Flow: 9 gpd

Do not use where water is microbiologically unsafe or with water of unknown quality, except that systems certified for cyst reduction may be used on disinfected waters that may contain filterable cysts.

¹ Claims for arsenic reduction shall only be made on water supplies maintaining detectable residual free chlorine at the reverse osmosis (RO) system inlet. Water systems using an in-line chlorinator should provide a minimum of 1 minute chlorine contact time before the RO system.

² This system is acceptable for treatment of influent perchlorate concentrations of no more than 100 ug/L.

Performance Data Sheet

WP-4v

Watts Premier Inc.

8716 W Ludlow Drive Sutie #1

Peoria, AZ 85381 85027 USA

GENERAL USE CONDITIONS:

1. System to be used with municipal or well water sources treated and tested on regular basis to insure bacteriological safe quality. DO NOT use with water that is microbiologically unsafe or unknown quality without adequate disinfection before and after the system. Systems certified for cyst reduction may be used on disinfected water that may contain filterable cysts.
2. Operating Temperature: Maximum: 100°F (40.5°C) Minimum: 40° (4.4°)
3. Operating Water Pressure: Maximum: 100 psi (7.0kg/cm2) Minimum: 40 psi (2.8kg/cm2)
4. pH 2 to 11
5. Maximum iron present in incoming feed water supply must be less than 0.2 ppm.
6. Hardness of more than 10 grains per gallon (170 ppm) may reduce RO membrane life expectancy.
7. Recommend TDS (Total Dissolved Solids) not to exceed 1800 ppm.

<u>Description</u>	<u>Replace</u>	<u>Cost</u>	<u>Description</u>	<u>Replace</u>	<u>Cost</u>
Sediment Filter			Stage 4 - VOC Block Filter		
▪ Part# 104017	6 Months	\$ 3.50	▪ Part# 101013	12 Months	\$24.95
Carbon Filter			(600 Gallons)		
▪ Part# 101009	6 Months	\$10.50	RO Membrane		
			▪ 35 GPD Part# 110016	2 to 5 Years	\$74.95
Depending upon incoming feed water conditions replacement time frame may vary.					
* All Prices Subject to change without notice			* All Prices Subject to change without notice		

This system has been tested according to NSF/ANSI 58 for reduction of the substances listed below. The concentration of the indicated substances in water entering the system was reduced to a concentration less than or equal to the permissible limit for water leaving the system as specified in NSF/ANSI 58. This system has been tested for the treatment of water containing pentavalent arsenic (also known as As (V), As (+5), or arsenate) at concentrations of 0.30 mg/L or less. This system reduces pentavalent arsenic, but may not remove other forms of arsenic. This system is to be used on water supplies containing a detectable free chlorine residual at the system inlet or on water supplies that have been demonstrated to contain only pentavalent arsenic. Treatment with chloramine (combined chlorine) is not sufficient to ensure complete conversion of trivalent arsenic to pentavalent arsenic. Please see the Arsenic Facts section of the Performance Data Sheet for further information.

	<u>Avg. In.</u> <u>(mg/L)</u>	<u>Avg. Eff.</u> <u>(mg/L)</u>	<u>% Reduction</u>	<u>pH</u>	<u>Pressure</u>	<u>Max Eff.</u> <u>mg/L</u>	<u>Inf. challenge</u> <u>concentration</u> <u>mg/L</u>	<u>Max Allowable</u> <u>concentration</u> <u>mg/L</u>
Arsenic (Pentavalent)	334.62 ug/L	5.039 ug/L	98.4%		50psi	19 ug/L	0.30±10%	0.010 mg/L
Barium Reduction	10.2	0.13	98.7%	7.24	50psi	0.27	10.0±10%	2.0
Cadmium Reduction	0.031	0.0001	99.7%	7.49	50psi	0.0009	0.03±10%	0005
Chromium (Hexavalent)	0.30	0.006	98.0%	7.24	50psi	0.013	0.03±10%	0.1
Chromium (Trivalent)	0.30	0.003	99.0%	7.24	50psi	0.008	0.03±10%	0.1
Copper Reduction	3.0	0.04	98.7%	7.64	50psi	0.06	3.0±10%	1.3
Cysts	222,077#/ml	10 #/ml	99.99%		50psi	58	minimum 50,000/mL	N/A
Fluoride Reduction	8.0	0.33	95.9%	7.49	50psi	0.47	8.0±10%	1.5
Lead Reduction	0.15	0.004	97.3%	7.49	50psi	0.008	0.15±10%	0.0107
Perchlorate	0.10	0.003	96.5%	7.39	50 psi	0.005 mg/L	0.10±10%	0.006
Radium 226/228	25pCi/L	5pCi/L	80.0%	7.24	50psi	5pCi/L	25pCiL±10%	5pCiL
Selenium	0.10	<0.001	99.0%		50psi	<0.001	0.10±10%	0.05
TDS	765	24	96%	7.84	50psi	39.0	750±40mg/L	187
Turbidity	81 NTU	0.15 NTU	99.8%		50psi	0.28 NTU	11±1 NTU	0.5 NTU

*Refer to the VOC Performance Data Sheet for the complete list of VOC's.

Recovery - 16.0%

Daily Production Rate - 9.56 GPD

Efficiency - 9.58%

Depending on water chemistry, water temperature, and water pressure Watts Premier's R.O. Systems production and performance will vary. Efficiency rating means the percentage of the influent water to the system that is available to the user as reverse osmosis treated water under operating conditions that approximate typical daily usage. Recovery rating means the percentage of the influent water to the membrane portion of the system that is available to the user as reverse osmosis treated water when the system is operated without a storage tank or when the storage tank is bypassed. There is an average of 4 gallons of reject water for every 1 gallon of product water produced.

REFER TO OWNER'S INSTALLATION/SERVICE MANUAL FOR FURTHER MAINTENANCE REQUIREMENTS AND WARRANTY INFORMATION.

Phone: (480) 675-7995

Fax: (623) 866-5666

Email: wpmail@watts.com

VOC Performance Data Sheet

Watts Premier Inc.

8716 W Ludlow Drive Sutie #1

Peoria, AZ 85381 USA

Substance	Percent Reduction	Influent Challenge Concentration (mg/L unless noted)	Maximum Permissible Product Water Concentration
ALACHLOR	>98%	0.05	0.001
ATRAZINE	>97%	0.1	0.003
BENZENE	>99%	0.081	0.001
BROMODICHLOROMETHANE (TTHM)	>99.8%	0.300 +/- 0.30	0.015
BROMOFORM (TTHM)	>99.8%	0.300 +/- 0.30	0.015
CARBOFURAN (Furadan)	>99%	0.19	0.001
CARBON TETRACHLORIDE	98%	0.078	0.0018
CHLOROBENZENE (Monochlorobenzene)	>99%	0.077	0.001
CHLOROPICRIN	99%	0.015	0.0002
CHLOROFORM (TTHM)	>99.8%	0.300 +/- 0.30	0.015
2, 4-D	98%	0.110	0.0017
DBCP (see Dibromochloropropane)	>99%	0.052	0.00002
1,2-DCA (see 1,2-DICHLOROETHANE)	95%	0.088	0.0048
1,1-DCE (see 1,1-DICHLOROETHYLENE)	>99%	0.083	0.001
DIBROMOCHLOROMETHANE (TTHM; Chlorodibromomethane)	>99.8%	0.300 +/- 0.30	0.015
DIBROMOCHLOROPROPANE (DBCP)	>99%	0.052	0.00002
o-DICHLOROBENZENE (1,2 Dichlorobenzene)	>99%	0.08	0.001
p-DICHLOROBENZENE (para-Dichlorobenzene)	>98%	0.04	0.001
1,2-DICHLOROETHANE (1,2-DCA)	95%	0.088	0.0048
1,1-DICHLOROETHYLENE (1,1-DCE)	>99%	0.083	0.001
CIS-1,2-DICHLOROETHYLENE	>99%	0.17	0.0005
TRANS-1,2- DICHLOROETHYLENE	>99%	0.086	0.001
1,2-DICHLOROPROPANE (Propylene Dichloride)	>99%	0.08	0.001
CIS-1,3- DICHLOROPROPYLENE	>99%	0.079	0.001
DINOSEB	99%	0.17	0.0002
EDB (see ETHYLENE DIBROMIDE)	>99%	0.044	0.00002
ENDRIN	99%	0.053	0.00059
ETHYLBENZENE	>99%	0.088	0.001
ETHYLENE DIBROMIDE (EDB)	>99%	0.044	0.00002
Furadan (see CARBOFURAN)	>99%	0.19	0.001
HALOACETONITRILES (HAN)			
BROMOCHLOROACETONITRILE	98%	0.022	0.0005
DIBROMOACETONITRILE	98%	0.024	0.0006
DICHLOROACETONITRILE	98%	0.0096	0.0002
TRICHLOROACETONITRILE	98%	0.015	0.0003
HALOKETONES (HK):			
1,1-DICHLORO-2-PROPANONE	99%	0.0072	0.0001
1,1,1-TRICHLORO-2-PROPANONE	96%	0.0082	0.0003
HEPTACHLOR	>99%	0.25	0.00001
HEPTACHLOR EPOXIDE	98%	0.0107	0.0002
HEXACHLOROBUTADIENE (Perchlorobutadiene)	>98%	0.044	0.001
HEXACHLOROCYCLOPENTADIENE	>99%	0.060	0.000002
LINDANE	>99%	0.055	0.00001
METHOXYCHLOR	>99%	0.050	0.0001
Methylbenzene (see TOLUENE)	>99%	0.078	0.001
Monochlorobenzene (see CHLOROBENZENE)	>99%	0.077	0.001
PCE (see TETRACHLOROETHYLENE)	>99%	0.081	0.001
PENTACHLOROPHENOL	>99%	0.096	0.001
Perchlorobutadiene (see HEXACHLOROBUTADIENE)	>98%	0.044	0.001
Propylene Dichloride (see 1,2 -DICHLOROPROPANE)	>99%	0.080	0.001
SIMAZINE	>97%	0.120	0.004
Silvex (see 2,4,5-TP)	99%	0.270	0.0016
STYRENE (Vinylbenzene)	>99%	0.15	0.0005
1,1,1-TCA (see 1,1,1 - TRICHLOROETHANE)	95%	0.084	0.0046
TCE (see TRICHLOROETHYLENE)	>99%	0.180	0.0010
1,1,2,2- TETRACHLOROETHANE	>99%	0.081	0.001
TETRACHLOROETHYLENE	>99%	0.081	0.001
TOLUENE (Methylbenzene)	>99%	0.078	0.001
2,4,5-TP (Silvex)	99%	0.270	0.0016
TRIBROMOACETIC ACID		0.042	0.001
1,2,4 TRICHLOROETHANE (Unsymtrichlorobenzene)	>99%	0.160	0.0005
1,1,1-TRICHLOROETHANE (1,1,1-TCA)	95%	0.084	0.0046
1,1,2-TRICHLOROETHANE	>99%	0.150	0.0005
TRICHLOROETHYLENE (TCE)	>99%	0.180	0.0010
TRIHALOMETHANES (TTHM) (Chloroform; Bromoform; Bromodichloromethane; Dibromochloromethane)	>99.8%	0.300 +/- 0.30	0.015
Unsym-Trichlorobenzene (see 1,2,4-TRICHLOROETHANE)	>99%	0.160	0.0005
Vinylbenzene (see STYRENE)	>99%	0.150	0.0005
XYLENES (TOTAL)	>99%	0.070	0.001

500109 (WP-4V)

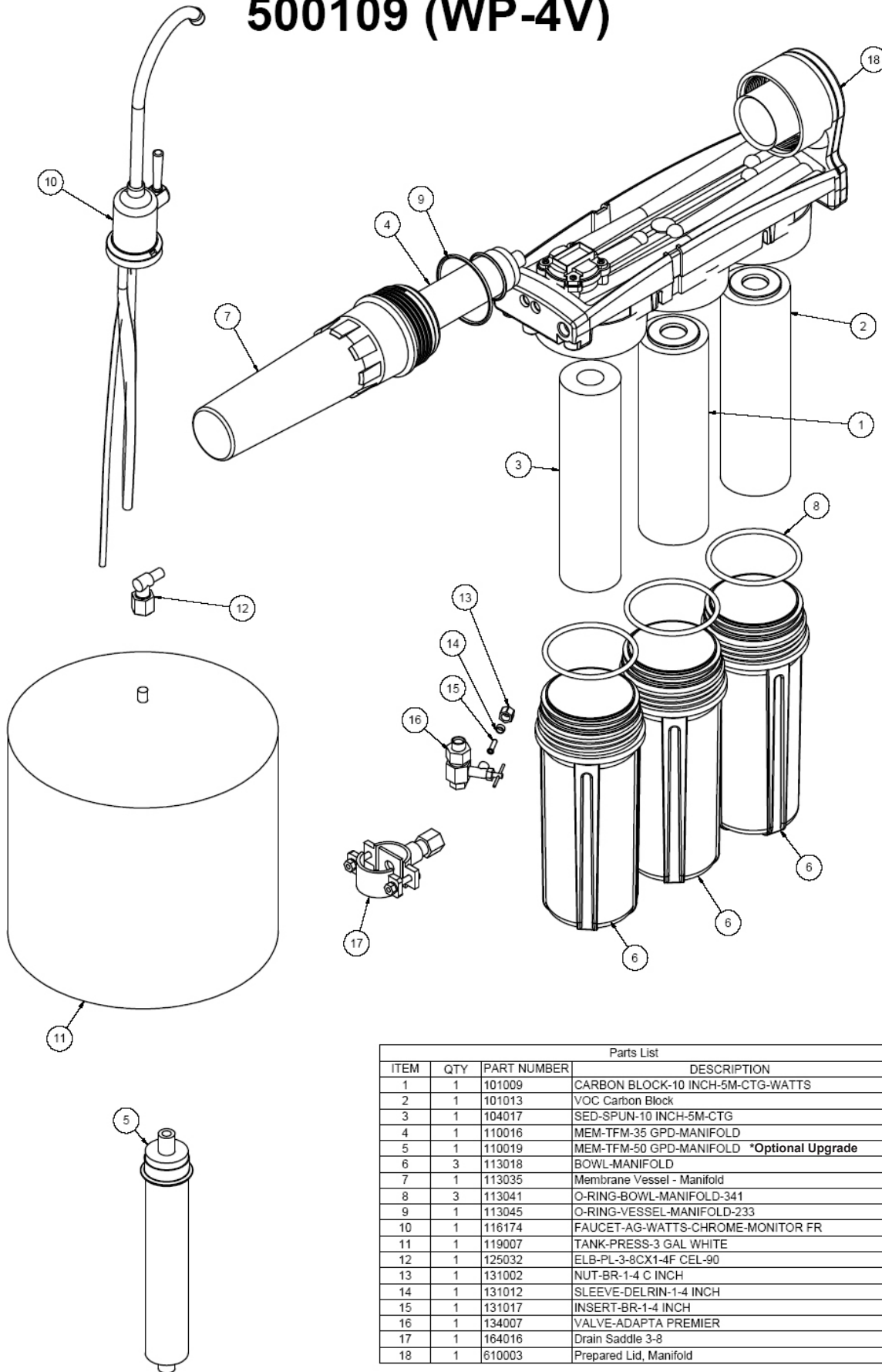

Parts List			
ITEM	QTY	PART NUMBER	DESCRIPTION
1	1	101009	CARBON BLOCK-10 INCH-5M-CTG-WATTS
2	1	101013	VOC Carbon Block
3	1	104017	SED-SPUN-10 INCH-5M-CTG
4	1	110016	MEM-TFM-35 GPD-MANIFOLD
5	1	110019	MEM-TFM-50 GPD-MANIFOLD *Optional Upgrade
6	3	113018	BOWL-MANIFOLD
7	1	113035	Membrane Vessel - Manifold
8	3	113041	O-RING-BOWL-MANIFOLD-341
9	1	113045	O-RING-VESSEL-MANIFOLD-233
10	1	116174	FAUCET-AG-WATTS-CHROME-MONITOR FR
11	1	119007	TANK-PRESS-3 GAL WHITE
12	1	125032	ELB-PL-3-8CX1-4F CEL-90
13	1	131002	NUT-BR-1-4 C INCH
14	1	131012	SLEEVE-DELRIN-1-4 INCH
15	1	131017	INSERT-BR-1-4 INCH
16	1	134007	VALVE-ADAPTA PREMIER
17	1	164016	Drain Saddle 3-8
18	1	610003	Prepared Lid, Manifold

Other Products from **WATTS Premier**

Watts Premier has other fine water filtration products and accessories to enhance your water and to compliment your existing RO System. Listed on the next several pages are just few of the items we have to offer. Visit our website at www.premierH2o.com or call our Customer Service Representatives at 1-800-752-5582 (inside USA) 1-480-675-7995 (outside USA) for more products.



VOC Filter Replacement Kit (5 pack)

Compatible with Watts Premier Reverse Osmosis and water filtration systems. These filters provide an extra level of filtration by allowing for more contact between the carbon media and your water.

Part No. 500124

***\$ 42.95/Kit**



50 GPD Membrane

Compatible with Watts Premier Reverse Osmosis systems, this 50 GPD membrane generates a greater amount of water per day for your RO system. Good application for households with higher levels of Nitrites & Nitrates. Contact Watts Premier if you are in need of a Nitrite/Nitrate test kit.

Part No. 110019 (50 GPD Membrane)

***\$ 80.95/ea**



3/8" Ice Maker Kit for RO and Filtration

3/8 inch connection includes 30 feet tubing, ball valve, and fittings.

Part No. 500102

***\$ 21.95/ea**



Watts Premier Hot Water Recirculation System

Bring convenience and saving to your home, giving you hot water instantly at every faucet, when you need it. This unique product is easy to install and not only provides you with the convenience of hot water when you need it, but saves an average of over 15,000 gallons per year.

Part No. 500800

***\$ 229.99 each**



PERMEATE PUMP KIT

Using only the available energy from the brine water (otherwise lost to the drain), the pump forces product water into the storage tank. This process effectively reduces membrane back pressure to less than 5 psi and allows the membrane to maximize its use of the available feed pressure.

- Fills product tank up to 4 times more rapidly
- Reduces waste water by as much as 80%
- Lowers "TDS creep"
- NSF approved (Standard 58)

Part No. 560041

***\$ 65.95/ea**

****All prices subject to change without notice.***



Top Mount Faucets by Watts Premier

These attractively designed faucets feature a long reach spout to compliment all styles of kitchen decor. The unique top mount design allows for easy above counter installation. The Monitored version of this faucet has an LED light that turns red to notify you for filter replacement.

- Part No. 116115 - Oil Rubbed Bronze (Non-Monitored) *\$67.95 each**
- 116095 - Brushed Nickel (Non-Monitored) *\$52.95 each**
- 116093 - Brushed Nickel (Monitored) *\$62.95 each**
- 116110 - Black (Non-Monitored) *\$60.47 each**



Watts Premier Ice Maker Filter Kit - High efficiency replaceable filter that can last up to 5 years or 20,000 gallons. Perfect for residential and commercial ice makers as well as refrigerators, drinking fountains, coffee & tea brewers, motor homes and campers. Reduces chlorine taste and odor.

Part No. 500318 *\$32.95/ea



Whole House Filter

Great for sediment problems such as in well water supply or areas where dirt and rust particles are a problem. Includes three 50 micron sediment filters and wrench (3/4" ports)

Part No. 500223 *\$42.95/ea

Replacement filter

Part No. 304007 *\$ 4.50/ea



Water Pressure Gauge

This gauge mounts onto your outside hose connection to accurately show your home's water pressure up to 300 psi. A red needle shows peak overnight pressure, which may exceed readings during the day. High pressure readings may indicate the need for a pressure regulator to prevent damage to appliances.

Part No. 261003 *\$11.50/ea



Pocket Total Dissolved Solids (TDS) Monitor

Test water electronically to verify reverse osmosis membrane effectiveness. Carrying case included.

Part No. 273001 *\$39.95/ea



Tank Ball Valve

Eliminates the need to drain the tank during normal filter changes. This easy to install valve attaches to the top of your water tank. The tank should always be drained after the membrane is changed.

Part No. 134023 *\$ 6.75/ea

**All prices subject to change without notice.*

Removing chlorine from your shower

Special Chlorgon & KDF media – More effective than carbon medias with hot water applications in the removal of the following.

- √ Free Chlorine (CL-)
- √ Combined Chlorine (Sodium Hypochlorite)
- √ Hydrogen Sulfide (Rotten egg smell)
- √ Plus, its pH balanced.
- √ Iron oxide (rust water)
- √ Dirt, sediment
- √ Odors



Deluxe Shower Handle with Built in Filter

5-Way Massaging Spray
72" Reinforced Hose
High Strength Bracket
Triple Plated Finish
Reversible Filter Cartridge (Model HHC)
Cartridge Life Rating: 3 months

Part No. 107070 WHITE *\$38.95
Part No. 107091 CHROME *\$44.95
Part No. 107092 GOLD *\$44.95

Replacement filters 2PK



Part No. 107075 *\$15.95/pk



Shower Falls Deluxe Shower Handle with Built in Filter

Curved Ergonomic Shower Handle
Filter Handle Extension
Dual Swivel Adjustment
Ultra Deluxe 5 Way Massaging Spray
72" Reinforced Hose
Chrome Plated Brass Bracket & Swivel Ball Extension
Triple Plated Finish
Reversible Filter Cartridge (Model HHC)
Cartridge Life Rating: 3 months

Part No. 107095 CHROME *\$55.95

Replacement filters 2PK



Part No. 107075 *\$15.95/pk



All-In-One reversible High-Flow Filter

Deluxe 5-Way Massaging Spray

Soft-Touch Adjustment Pads
Anti-Scaling Spray Nozzle
High Strength Housing
Triple Plated Finish
Cartridge Life Rating: 6 months

Part No. 107098 White/Chrome *\$39.95
Part No. 107099 White/Gold *\$39.95

Replacement filter



Part No. 107080 *\$13.95/ea

***All prices subject to change without notice.**

WARRANTY REGISTRATION

Thank you for selecting Watts Premier for your water filtration needs.

4 Ways to Register

1. Online at www.premierH2o.com

Register your product online and receive a 5% discount on your next online order, Plus receive reduced shipping.

2. Call in your information 1-800-752-5582

Call and we will enter your information.

3. Fax in your information 623-866-5666

Fax this form directly to us.

4. Mail in the information.

Please complete the form below. Mail to: **Watts Premier**
8716 W Ludlow Drive Suite #1
Peoria, AZ 85381

Registering will
insure you
receive Watts
FREE
Filter
Reminder
Notice

Watts Premier Inc. is concerned for the safety of your personal information. Watts Premier collects personal information when you register with Watts Premier. This information is stored in our data base and we do not rent, sell, or share personal information with other people or nonaffiliated companies. We reserve the right to send you certain types of communications such as direct mail, email, or by telephone relating to our products or products that you have purchased. We limit access to your personal information to those employees who will directly provide you with services or products in order to do their jobs. We want to offer you four ways to communicate with us. 1.Online, 2.Fax, 3.Telephone, and 4. Mail the form below. By registering your product you will receive the full benefit of our warranty. Watts Premier will also send you a semiannual filter change reminder beginning six months from date of installation. To insure the highest quality of your water, filters should be replaced every 6 months. If you have any questions or comments please give us a call at 1-800-752-5582 M-F 8:00am -5:00pm MST.



First Name: _____ Last Name: _____

Address: _____ City: _____

State: _____ Zip Code: _____

Country: USA CANADA MEXICO OTHER _____

Phone # _____ - _____ - _____ Email Address: _____

Date of Purchase: _____ Date of Install: _____

Installed By: SELF Plumbing Professional Where Purchased: _____

Model Number: _____ Serial Number: _____ - _____
xxxxxx - xxxxxx

Watts Premier, Inc.
Phone: 800-752-5582

8716 W Ludlow Drive Suite #1
www.premierH2o.com

Peoria, AZ 85381
Fax: 623-866-5666

Service Record

Serial No. _____

Date of Purchase: _____ Date of Install: _____ Installed by: _____

Date	1st stage Sediment (6 months)	2nd stage Carbon (6 months)	4th stage VOC Block (1 year)	3rd stage Membrane (2-5 years)	

NOTES:

Limited Warranty

What your Warranty Covers:

If any part of your WATTS PREMIER Reverse Osmosis System is defective in workmanship (excluding replaceable filters and membranes), return unit after obtaining a return authorization (see below), less tank, within 3 years of original retail purchase, WATTS PREMIER will repair or, at WATTS PREMIER'S option, replace the system at no charge.

How to obtain Warranty Service:

For warranty service, call 1-800-752-5582 for documentation and a return authorization number. Once the return authorization number has been created, ship your Reverse Osmosis unit (less tank) to our factory, freight and insurance prepaid, with proof of date of original purchase. Include a note stating the problem experienced and include your name, address and your return authorization number. No returns will be accepted with out the proper return authorization number. Premier will repair it, or replace it, and ship it back to you prepaid.

What this warranty does not cover:

This warranty does not cover defects resulting from improper installation, (contrary to WATTS PREMIER's printed instructions), from abuse, misuse, misapplication, improper maintenance, neglect, alteration, accidents, casualties, fire, flood, freezing, environmental factors, water pressure spikes or other such acts of God.

This warranty will be void if defects occur due to failure to observe the following conditions:

1. The Reverse Osmosis System must be hooked up to a potable municipal or well cold water supply.
2. The hardness of the water should not exceed 10 grains per gallon, or 170 ppm.
3. Maximum incoming iron must be less than 0.2 ppm.
4. The pH of the water must not be lower than 2 or higher than 11.
5. The incoming water pressure must be between 40 and 100 pounds per square inch.
6. Incoming water to the RO cannot exceed 105 degrees F (40 degrees C.)
7. Incoming TDS/Total Dissolved Solids not to exceed 1800 ppm.
8. Do not use with water that is microbiologically unsafe or of unknown quality without adequate disinfection before or after the system.

This warranty does not cover any equipment that is relocated from the site of its original installation.

This warranty does not cover any equipment that is installed or used outside the United States of America and Canada.

LIMITATIONS AND EXCLUSIONS:

WATTS PREMIER WILL NOT BE RESPONSIBLE FOR ANY IMPLIED WARRANTIES, INCLUDING THOSE OF MERCHANTABILITY AND FITNESS FOR A PARTICULAR PURPOSE. PREMIER WILL NOT BE RESPONSIBLE FOR ANY INCIDENTAL OR CONSEQUENTIAL DAMAGES, INCLUDING TRAVEL EXPENSE, TELEPHONE CHARGES, LOSS OF REVENUE, LOSS OF TIME, INCONVENIENCE, LOSS OF USE OF THE EQUIPMENT, AND DAMAGE CAUSED BY THIS EQUIPMENT AND ITS FAILURE TO FUNCTION PROPERLY. THIS WARRANTY SETS FORTH ALL OF PREMIER'S RESPONSIBILITIES REGARDING THIS EQUIPMENT.

OTHER CONDITIONS:

If PREMIER chooses to replace the equipment, WATTS PREMIER may replace it with reconditioned equipment. Parts used in repairing or replacing the equipment will be warranted for 90 days from the date the equipment is returned to you or for the remainder of the original warranty period, whichever is longer. This warranty is not assignable or transferable.

YOUR RIGHTS UNDER STATE LAW:

Some states do not allow limitations on how long an implied warranty lasts, and some states do not allow the exclusion or limitation of incidental or consequential damages, so the above limitations or exclusions may not apply. This warranty gives you specific legal rights, and you may have other legal rights which vary from state to state.