

INSTALLATION MANUAL

MULTI-MONITOR MOUNT FLAT PANEL DISPLAY MOUNT



Model # MMT



Model # MMW

 **PREMIER
MOUNTS™**
The original holding company

3130 E. Miraloma Ave. Anaheim, CA 92806 Phone: 800 368-9700 Fax: 800 832-4888

www.mounts.com

Contents

- Assembly drawing
- Parts list
- Mounting the table top stand
- mounting LCD monitor to multi-mount assembly
- Threading cables through post
- Mounting Multi-Monitor assembly to the wall
- Making adjustments to the Multi-Monitor assembly

WARNING!

The wall structure or table top must be capable of supporting at least five (5) times the weight of the flat panel(s). If not, the wall or table top must be reinforced. Proper installation procedure by qualified personnel as outlined in the installation instructions must be adhered to. Failure to do so could result in serious personal injury.

WARNING Safety precaution measures must be practiced at all times during the installation of this product. Use proper safety gear and tools for the installation procedure to prevent personal injury.

The entire installation instructions should be fully read and understood, including all of the safety symbols and safety precautions, before beginning installation. The installation instructions should be read, understood and followed to prevent personal injury or property damage. Keep these installation instructions in an easily accessible location for future reference.



Indicates that the power plug is to be disconnected from the power outlet.



Contact Premier Mounts for any questions



Safety precautions must be taken at all times.

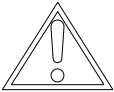

Warning and caution in general



A secured structure wooden stud wall must always support the weight or load of the flat panel(s). Always confirm the center of the wood stud before beginning the installation.



Do not install in locations where there is vibration, movement or danger of impact. Failure to do so could result in flat panel(s) cracking or falling from the wall causing damage and injury.

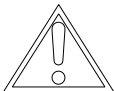

Do not install near heater, fireplace, direct sunlight or air conditioning or any other source of direct heat energy. Failure to do so may result in damage to the flat panel(s) and could cause a risk of fire.



Mounting structure recommended wood studs, solid-flat concrete, and reinforced metal studs. If installing the mount on other than wood studs use (commercially available) suitable hardware.

Assembly drawings

Dimensions are in Inches and (mm)

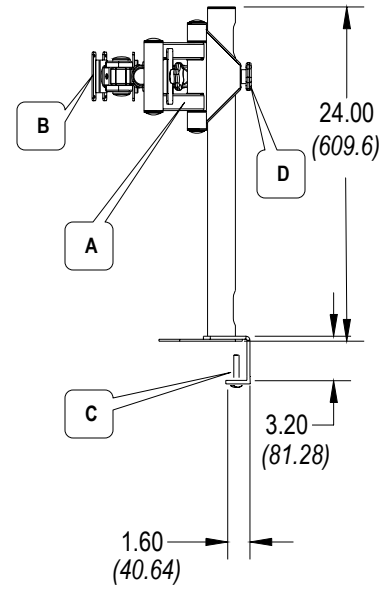
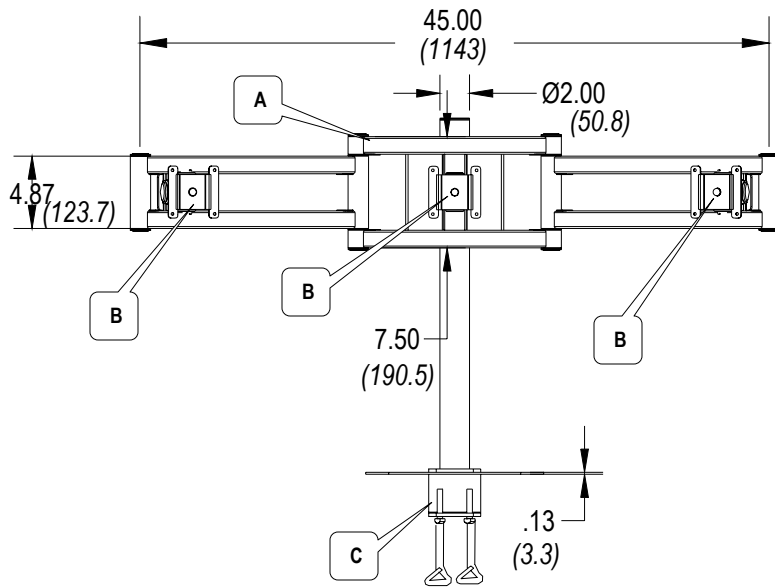

Model: MMT

Description

- A. Adjustable Multi-Monitor assembly
- B. Flat Panel Mounting brackets VESA 75/100
- C. Removable desk clamp
- D. Adjustable safety knob
- E. Wall mount
- F. Set screw

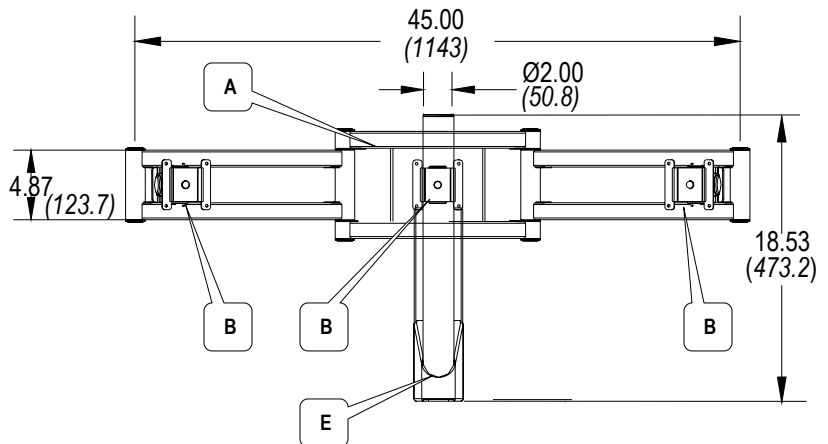
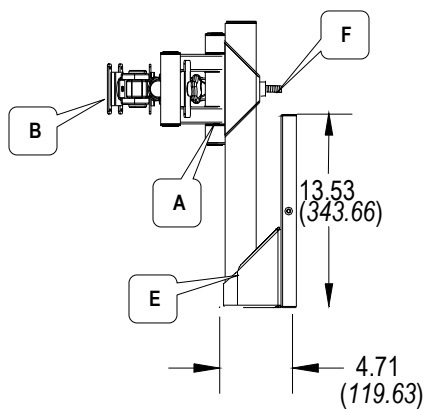

Model: MMW

Parts list

NOTE: This wall mount is shipped with all proper installation hardware and components. Make sure that none of these parts are missing before beginning installation. If there are parts missing stop the installation and contact Premier Mounts.

Wood screws (4)

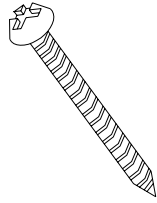

Wedge anchors (4)

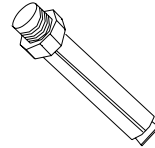

M4 X 10 phillips
Head screws (12)

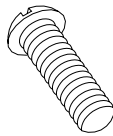

Set screw (1)

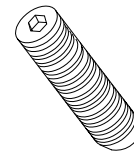

Allen wrench (1)

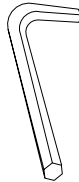

Multi-Monitor assembly

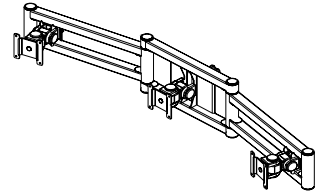

Wall mount
For use on model: MMW

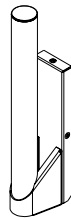

Desk mount
For use on model: MMT

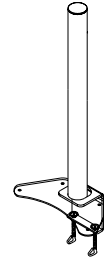

Mounting the Multi-Monitor Mount to a desk or hard surface (model: MMT)

WARNING: Proper installation procedure by qualified personnel as outlined in the installation instructions must be adhered to. Failure to do so could result in serious personal injury and possible damage to the flat panel(s).

Figure 1

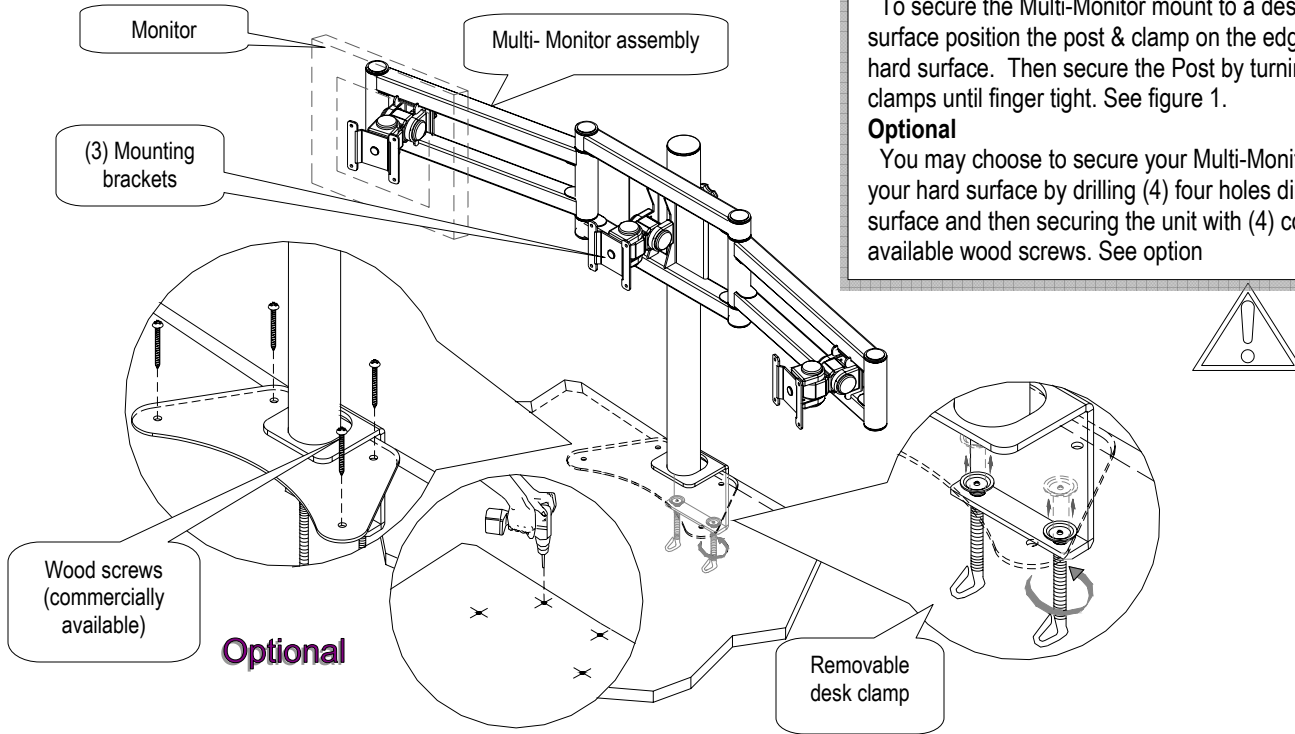

Step 1

To secure the Multi-Monitor mount to a desk or hard surface position the post & clamp on the edge of the desk or hard surface. Then secure the Post by turning the two desk clamps until finger tight. See figure 1.

Optional

You may choose to secure your Multi-Monitor directly to your hard surface by drilling (4) four holes directly in the surface and then securing the unit with (4) commercially available wood screws. See option

Step 2

Using the (4) M4 X 10 phillips screws (supplied) secure your monitor or monitors to the mounting brackets. See figure 2.

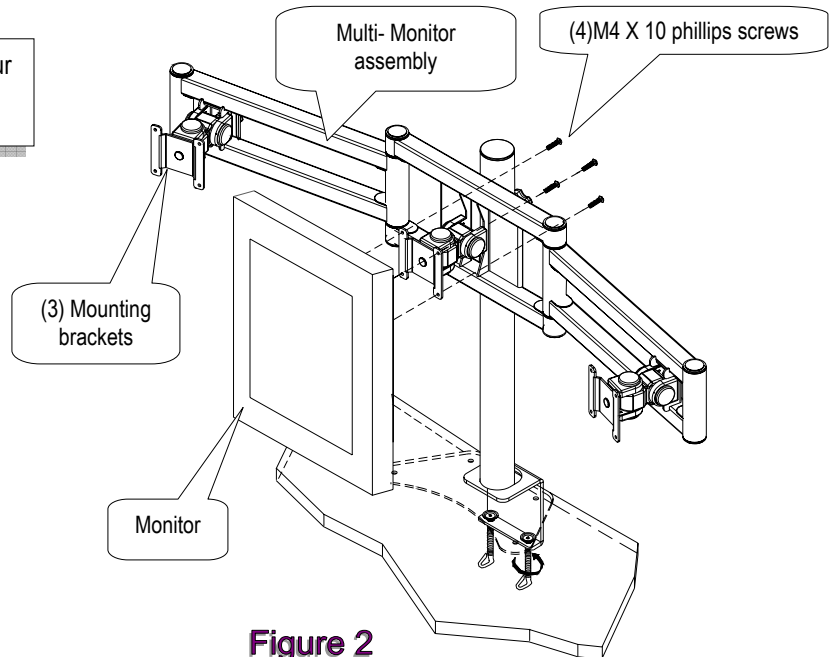
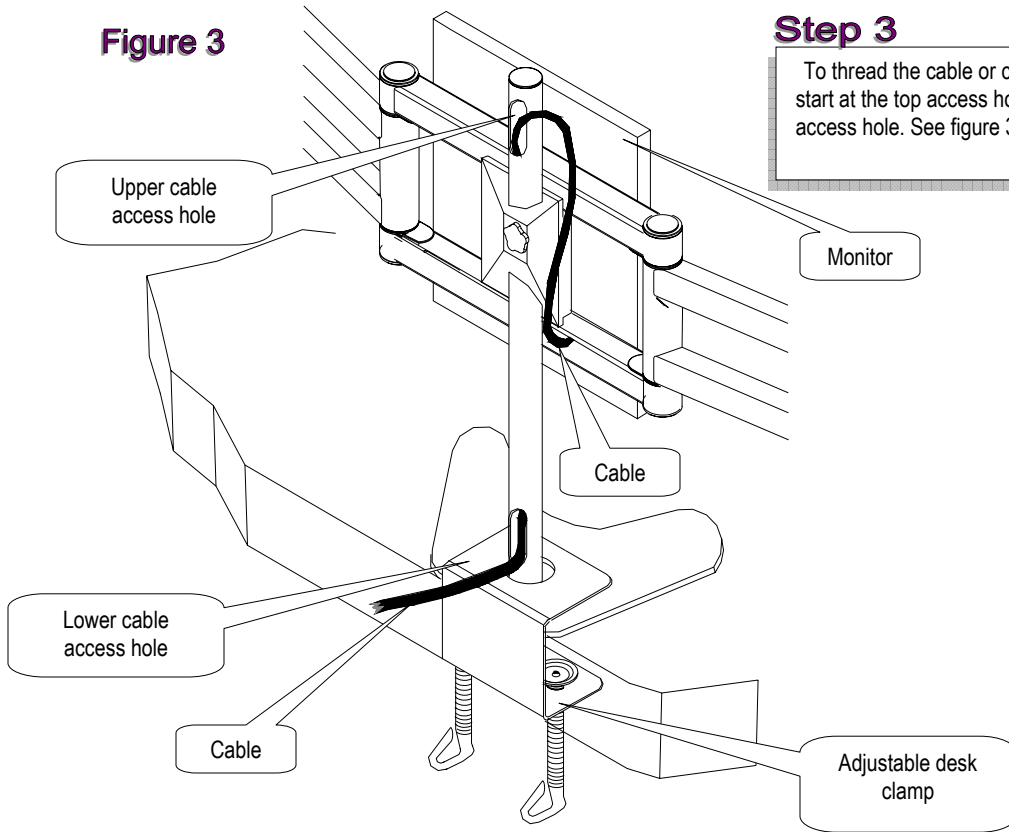

Figure 2

Threading cables through cable access holes (model: MMT)

Figure 3



Step 3

To thread the cable or cables from the monitor through the post, start at the top access hole and gently pull cable out of the bottom access hole. See figure 3



Mounting Multi-Monitor Mount to wall or concrete (model: MMW)

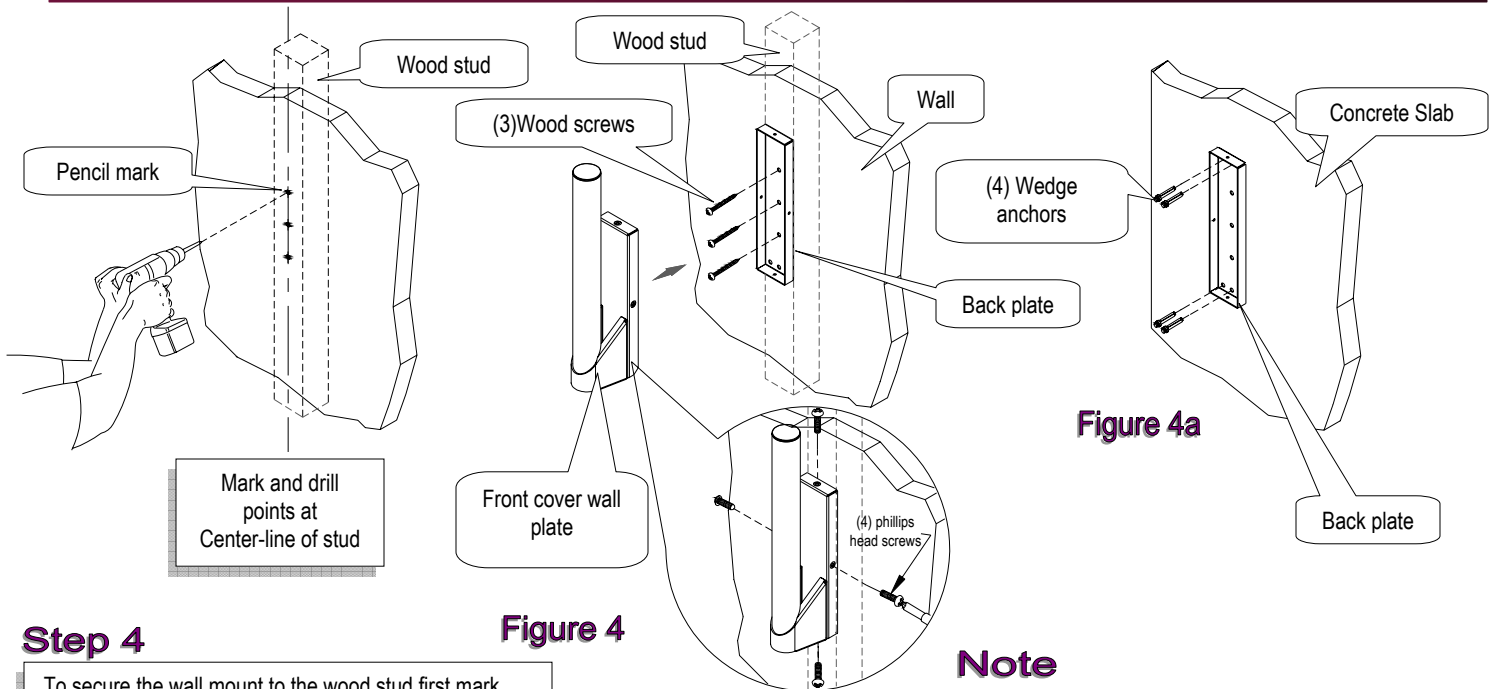

Step 4

To secure the wall mount to the wood stud first mark three points with a pencil and then drill pilot holes to start. Using (3) wood screws (supplied) screw the back plate to the wall. Then secure the front plate with the (4) M4 X 10 phillips screws (supplied). See figure 4

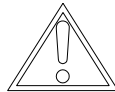

Note

To secure the back wall plate into a concrete wall use (4) wedge anchors (supplied). See figure 4a

Mounting Multi-Monitor assembly to wall mount (model: MMW)

Figure 5

Step 5

Align the Multi-Monitor Assembly with the wall mount and slide the arm down around the wall mount post. To secure the arm to the wall mount, finger tighten the safety knob until the arm is secure. See figure 5

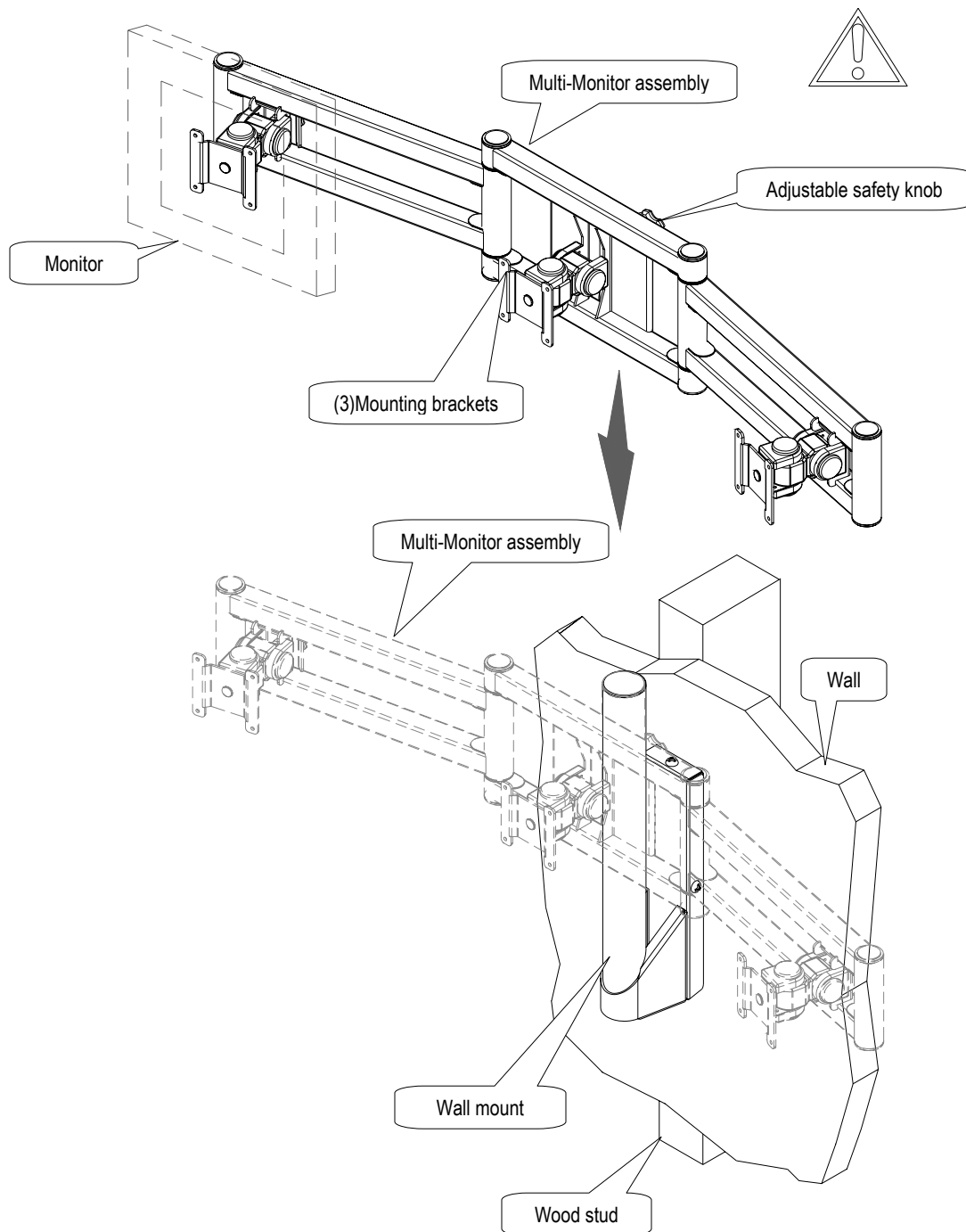

Adjustments

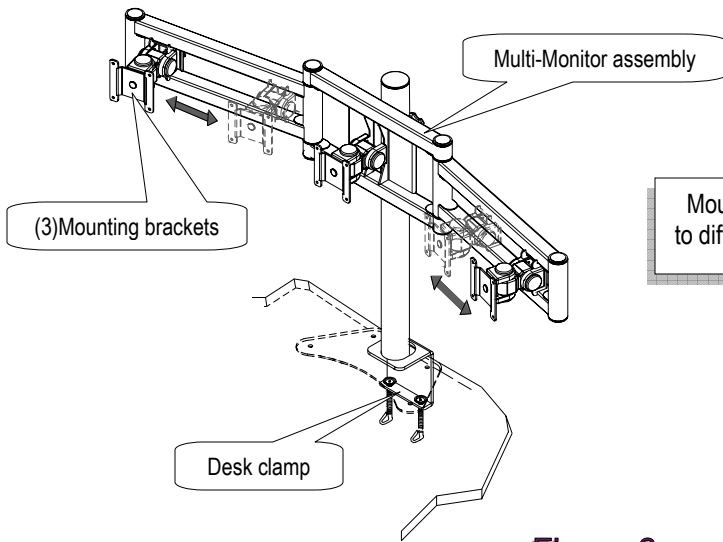

Mounting brackets on arms only slide inward and outward to different positions. See figure 6

Figure 6

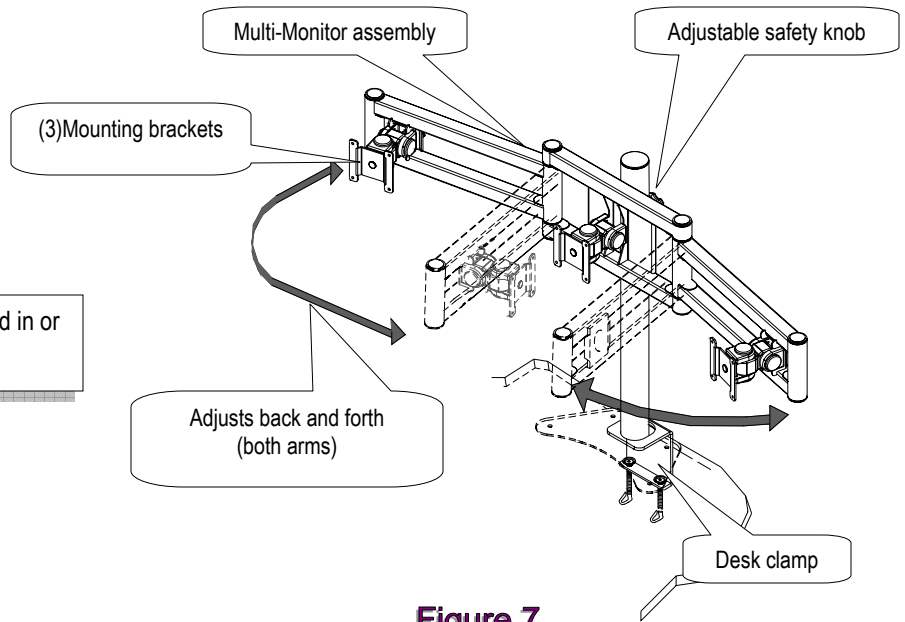

The arms of the Multi-Monitor assembly can be pulled in or out for desired positions. See figure 7

Figure 7

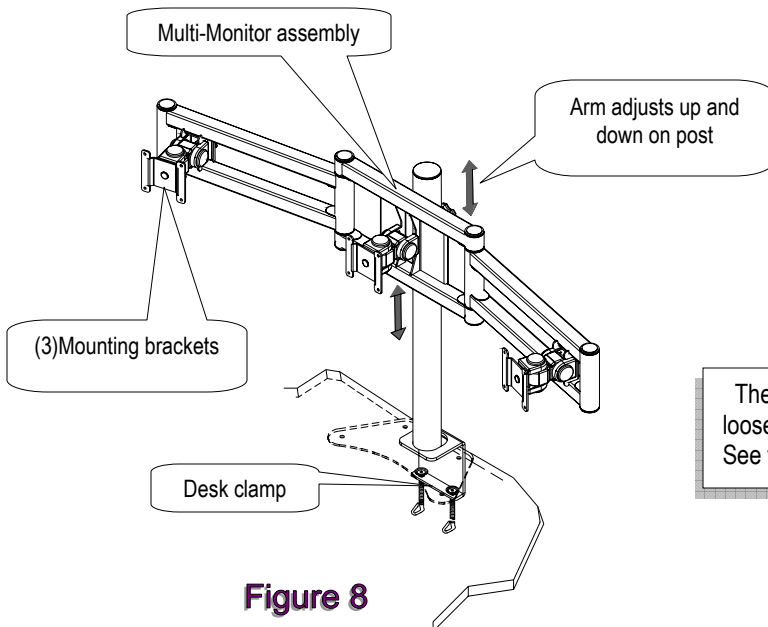

The Multi-Monitor assembly is adjusted up and down by loosening and tightening the adjustable safety knob. See figure 8

Figure 8