

IMPORTANT: READ ENTIRE INSTRUCTION BEFORE ASSEMBLY

PARTS LIST

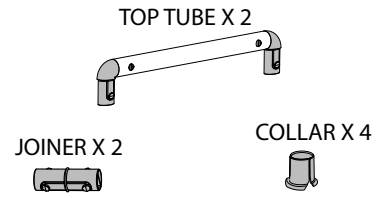
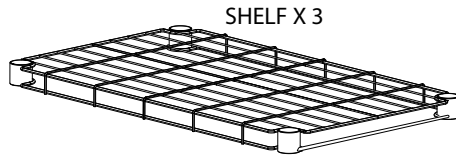
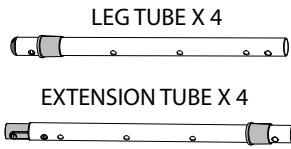

Insert the 4 leg tubes (rubber feet on bottom) into the corners of a shelf.

1

Note: Shelves can be mounted either way, as tray or flat shelf

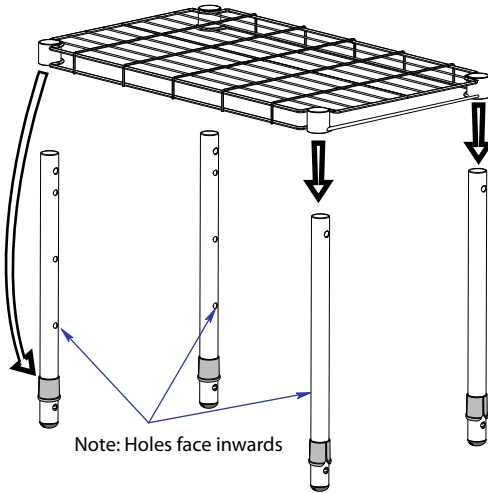

Slide on next shelf to rest on the bottom

2

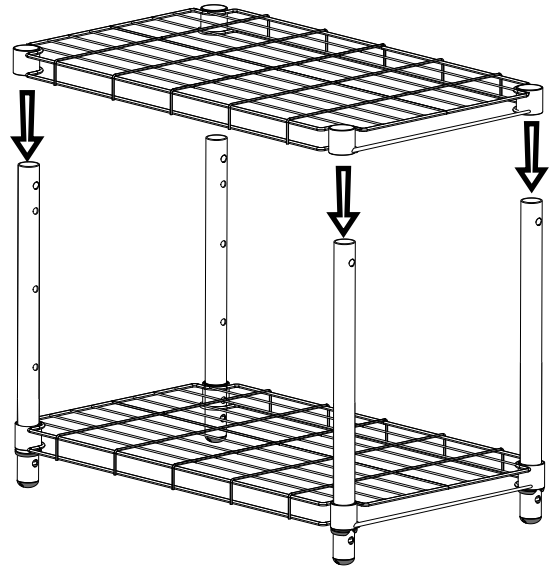

Insert extension tubes with joiners. Keep holes facing inwards.

3

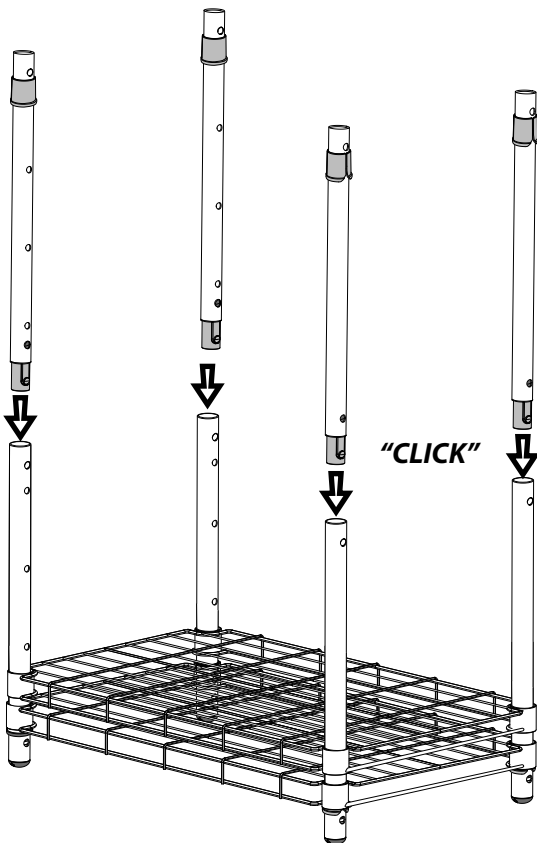

Place top shelf onto plastic collars on extension tubes.

4

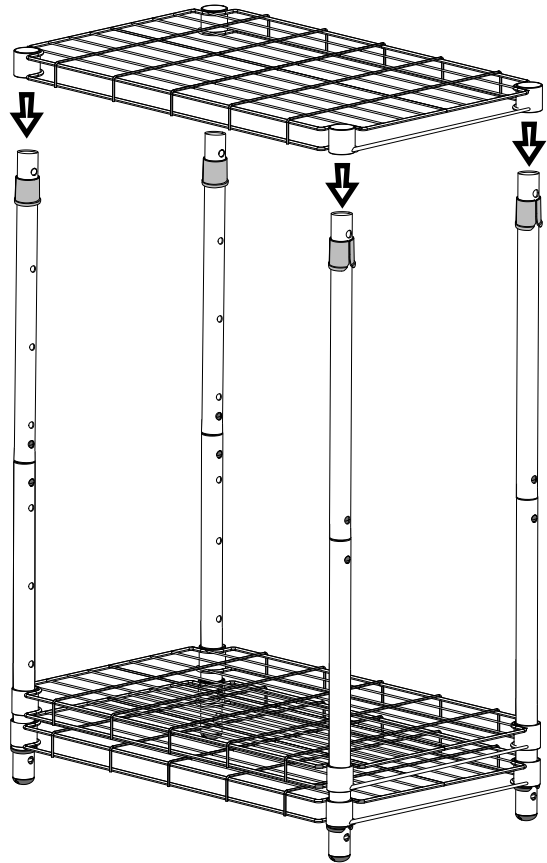

SEE OVER



Delta Cycle Corporation
125 Washinton Street
Foxborough, MA 02035 USA

3 SHELF UNIT WS1003
ASSEMBLY DIAGRAM

© Copyright 2010

IMPORTANT: READ ENTIRE INSTRUCTION BEFORE ASSEMBLY

Connect the two top tubes to the 4 extension tubes.

5

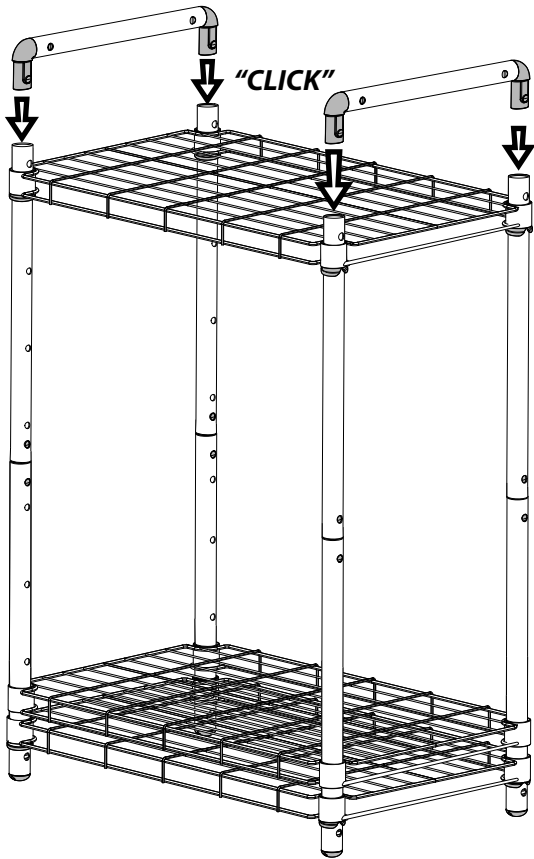

Determine the desired height of the middle shelf and then slide shelf above the selected holes. Attach the four plastic collars at the desired height.

6

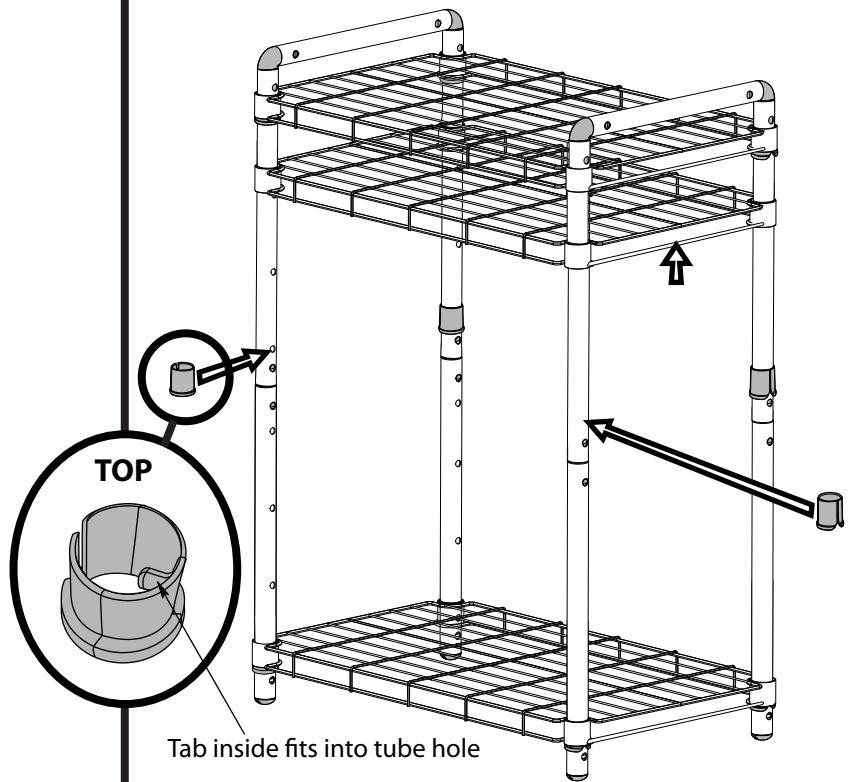

Press the corners of middle shelf onto the 4 plastic collars. Seat all corners of each shelf onto its plastic collar to keep unit rigid.

7

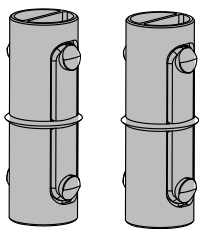

INCLUDED:
2 spare Joiners allow
for stacking extra racks.

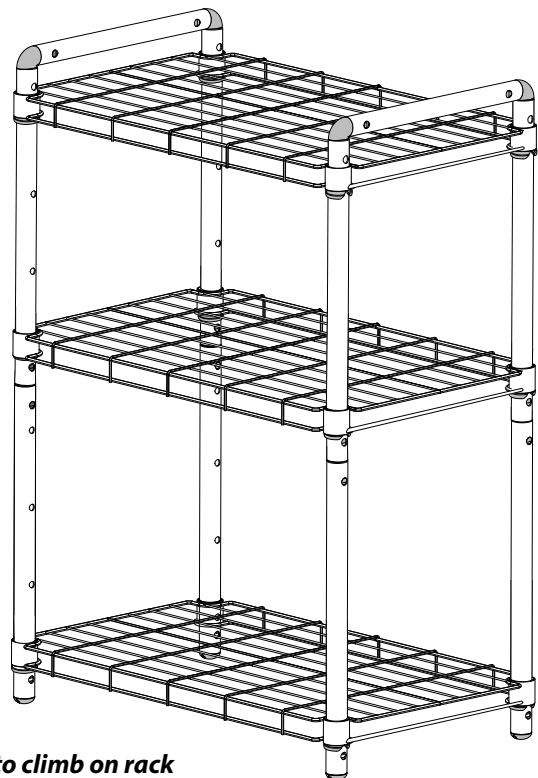
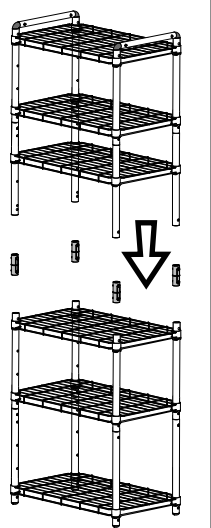

Maximum load per shelf (spread evenly): 160lbs (75kgs)

SAFETY WARNING: Do not use as a step ladder. Never allow children to climb on rack

SEE OVER



Delta Cycle Corporation
125 Washington Street
Foxborough, MA 02035 USA

3 SHELF UNIT WS1003
ASSEMBLY DIAGRAM

© Copyright 2010