

	QTY	HARDWARE DESCRIPTION
A	1	Lever Latch
B	1	U bracket
C	1	Thread Forming Screw
D	1	M5 Hex Head Machine Screw
E	1	M5 Hex Nut
F	1	Key
G	8	Grommet, 2"
H	6	Nut, 10-24 Keps
J	6	Machine Screw, 10-24 x 1-1/2"

The
POWER *In*
PRESENTATION PRODUCTS

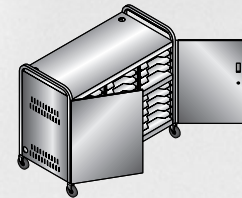

Assembly Instructions
for
ADVANCE
LAPTOP STORAGE
CART CT-LS30



DA-LITE SCREEN COMPANY, INC.
3100 North Detroit Street
Post Office Box 137
Warsaw, Indiana 46581-0137
Phone: 574-267-8101
800-622-3737
Fax: 574-267-7804
www.da-lite.com
e-mail: info@da-lite.com

PROCEDURE

Tools Required

3/8" box wrench, Phillips screwdriver, Flat head screw driver, adjustable wrenches

Procedure

1. Remove contents from carton and examine parts.
2. Insert Casters into caster sockets making sure they are seated properly. See Figure 1.

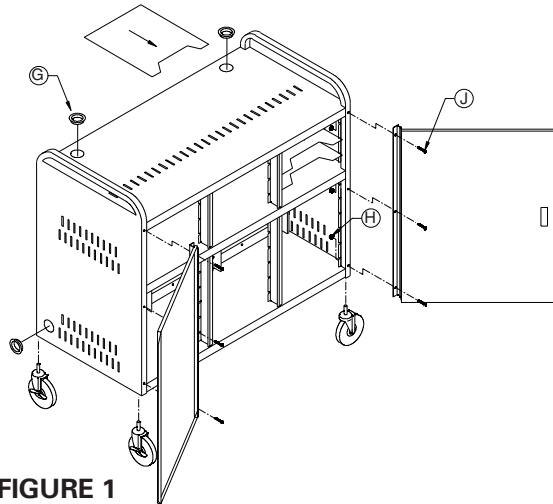
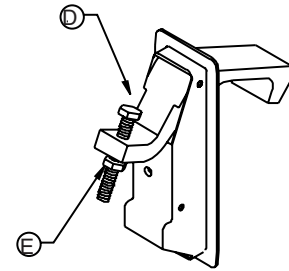

FIGURE 1

3. Attach doors to the cart using the fasteners shown. See Figure 1.
4. Remove Lever Latch from package and assemble screw (item D) and hex nut (item E) to it as shown. See Figure 2.



LEVER LATCH

FIGURE 2

5. Assemble Lever Latch to Right Hand Door with U bracket and screw as shown. See Figure 3.

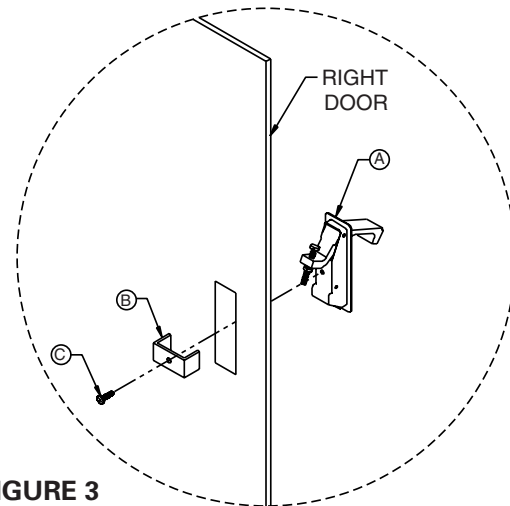

FIGURE 3

6. Remove Back Panel by turning fasteners 1/4 turn in either direction. Install all of the Grommets.
7. Insert Dividers into notches on the divider supports from the backside of cart as shown. (See Figure 1)
8. Re-attach Back Panel to cart.