



# TENSIONED DUAL MASKING ELECTROL®

Automatic Electric Projection Screen Model

## SPECIFICATION DATA

DA-LITE SCREEN COMPANY, INC.  
3100 North Detroit Street  
Post Office Box 137  
Warsaw, Indiana 46581-0137  
Phone: 574-267-8101  
800-622-3737  
Fax: 574-267-7804  
Toll Free Fax: 877-325-4832  
www.da-lite.com  
e-mail: info@da-lite.com

**SUGGESTED SPECIFICATIONS:** \_\_\_\_\_ projection screen(s), \_\_\_\_\_ (H) x \_\_\_\_\_ (W), electrically operated 120 volt (60 Hz) not more than 4.8 amp. Shall have two specially designed motors mounted inside two rollers, to be three wire with ground quick reversal type, oiled for life, with automatic thermal overload cutout, integral gears, capacitor and an electric brake to prevent coasting. To have pre-set limit switches to automatically stop picture surfaces in the "up" and "down" positions. The fabric roller to be of rigid aluminum. The mask roller to be of rigid metal. Screen fabric to be seamless, flame retardant and mildew resistant vinyl with black masking borders standard. Each side of the fabric to have tab guide cable system to maintain even lateral tension and hold surface flat. To have masking fabric on sides to convert the screen to different aspect ratios. Bottom of fabric to be inserted into an aluminum slat bar with added weight to maintain vertical tension on the screen surface. The ends of the slat to be protected by heavy duty plastic caps enclosing a preset adjustable mechanism for screen tensioning. Bottom of each masking fabric shall be formed into a pocket holding a flat steel bar. Case to be of wood and be finished with a black primer coat, ready to accept final finish by others. To be complete with a three position control switch and a two position control switch in a two gang box with cover plate. Screen to be listed by Underwriters' Laboratories.



**All viewing surfaces will be seamless.**

**All viewing surfaces are standard with black backing except Da-Tex® and Dual Vision.**

**Audio Vision, High Contrast Audio Vision, High Contrast Cinema Perf and HD Progressive 1.1 Perf available in sizes up to 87" x 155" in HDTV Format and 87" x 161" in Letterbox Format.**

### HDTV TO NTSC VIDEO FORMAT DIMENSIONS

HDTV Format Viewing Area		HDTV Nominal Diagonal		NTSC Video Viewing Area (By masking)		NTSC Video Nominal Diagonal		* Overall Length of Case		Approx. Ship. Wt.	
H x W	Cm	In.	Cm	H x W	Cm	In.	Cm	In.	Cm	Lbs.	Kg
45" x 80"	114 x 203	92"	234	45" x 60"	114 x 152	75"	191	103¼"	262	117	53.1
50" x 89"	127 x 226	102"	259	50" x 67"	127 x 170	84"	213	112¾"	286	123	55.8
54" x 96"	137 x 244	110"	279	54" x 72"	137 x 183	90"	229	120¼"	305	132	59.9
60" x 107"	152 x 272	122"	310	60" x 80"	152 x 203	100"	254	131¾"	335	145	65.8
69" x 123"	175 x 312	141"	358	69" x 92"	175 x 234	120"	305	149¾"	380	163	73.9
87" x 155"	221 x 394	177"	450	87" x 116"	221 x 295	150"	381	184¾"	469	186	84.4

### LETTERBOX TO NTSC VIDEO FORMAT DIMENSIONS

Letterbox Format Viewing Area		Letterbox Nominal Diagonal		NTSC Video Viewing Area (By masking)		NTSC Video Nominal Diagonal		* Overall Length of Case		Approx. Ship. Wt.	
H x W	Cm	In.	Cm	H x W	Cm	In.	Cm	In.	Cm	Lbs.	Kg
50" x 92½"	127 x 235	105"	267	50" x 67"	127 x 170	84"	213	116¼"	295	117	50.4
60" x 111"	152 x 282	126"	320	60" x 80"	152 x 203	100"	254	135¾"	345	140	63.5
69" x 128"	175 x 325	145"	368	69" x 92"	175 x 234	120"	305	154¾"	393	157	71.2
87" x 161"	221 x 409	183"	465	87" x 116"	221 x 295	150"	381	190¾"	485	180	81.7

### CINEMASCOPE TO HDTV FORMAT DIMENSIONS

Cinemascope Format Viewing Area		Cinemascope Nominal Diagonal		HDTV Viewing Area (By masking)		HDTV Nominal Diagonal		* Overall Length of Case		Approx. Ship. Wt.	
H x W	Cm	In.	Cm	H x W	Cm	In.	Cm	In.	Cm	Lbs.	Kg
45" x 106"	114 x 269	115"	292	45" x 80"	114 x 203	92"	234	129¼"	328	145	65.8
49" x 115"	124 x 292	125"	318	49" x 87"	124 x 221	100"	254	138¾"	352	155	70.3
52" x 122"	132 x 310	133"	338	52" x 92"	132 x 234	106"	269	146¼"	371	161	73.0
54" x 126"	137 x 320	138"	351	54" x 96"	137 x 244	110"	279	150¼"	382	168	76.2
58" x 136"	147 x 345	148"	376	58" x 104"	147 x 345	119"	302	160¾"	408	175	79.4
65" x 153"	165 x 389	166"	422	65" x 116"	165 x 295	133"	338	178¾"	454	189	85.7

All screen sizes listed are viewing areas.

\*Add 3" (76mm) overall length of case for mounting brackets.

Overall case length dimensions ±¼" (6mm).

**All sizes come standard with 12" (305mm) black drop at top.**

Extra drop may alter case dimensions. Contact Da-Lite for details.

Detail dimensional drawings, wiring diagrams and installation instructions available upon request.

Specifications subject to change without notice.

Custom formats and sizes available upon request.

**WHEN ORDERING, MARK APPROPRIATE SELECTIONS:**

Select size from charts on first page.

**Viewing surface:**

- Da-Mat®
- High Contrast Da-Mat®
- Pearlescent
- Cinema Vision
- High Contrast Cinema Vision
- High Contrast Cinema Perf
- HD Progressive 1.1 Perf
- Audio Vision
- High Contrast Audio Vision
- Da-Tex® (Rear)
- Dual Vision

GREENGUARD® and GREENGUARD® Children and Schools Certified.

**Optional Accessories:**

- Dual Motor Low Voltage Control System (DMC).
- Wireless Remote Control for DMC.
  - Radio Frequency Remote.
  - Radio Frequency Range Extender available
  - Infrared Remote.
- 220 Volt (50Hz) Motor.

Project: \_\_\_\_\_

Architect: \_\_\_\_\_

Phone: \_\_\_\_\_

Contractor: \_\_\_\_\_

Phone: \_\_\_\_\_

Supervisor: \_\_\_\_\_

Phone: \_\_\_\_\_

Date: \_\_\_\_\_

Revised: \_\_\_\_\_

- White box (black standard).
- Silent Motor (available on sizes up to 10' x 10').

**TENSIONED DUAL MASKING ELECTROL®  
METHODS OF INSTALLATION**

**SELECT INSTALLATION METHOD  
ACCORDING TO CEILING TYPE.**

**NOTE:**  
MUST MARK HOLE LOCATION OF  
SCREWS IN 3 1/2" PANEL FOR  
REMOVAL, IF COVERING WITH TILE.

**NOTE:** Drawings below  
show picture surface  
and masks in the down  
position. Masks will be  
on front side of roller  
when retracted.

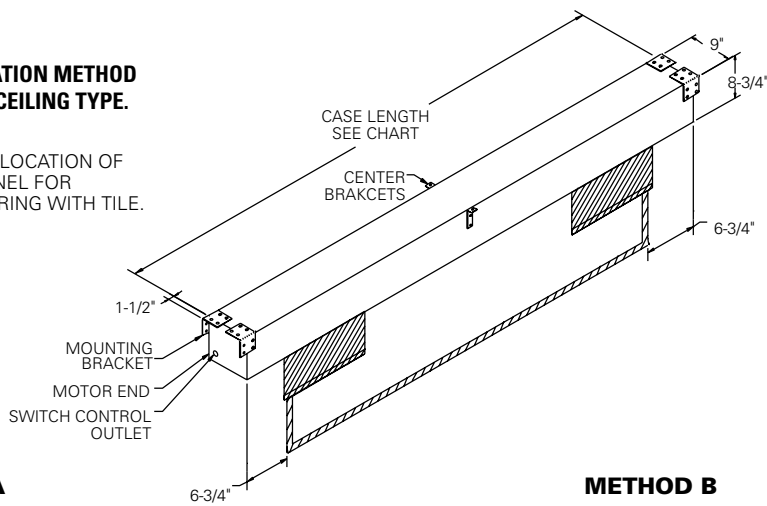

**METHOD A**

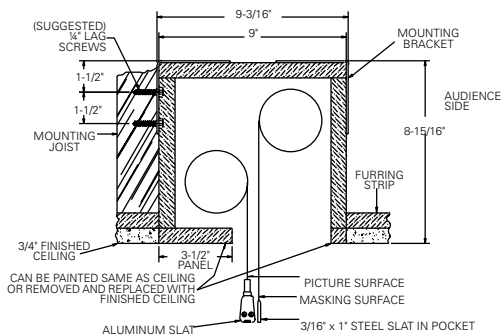

Offset mounting, recessed above ceiling. For plaster, dry wall, tile or paneling. Bottom of case painted same finish as ceiling.

**METHOD B**

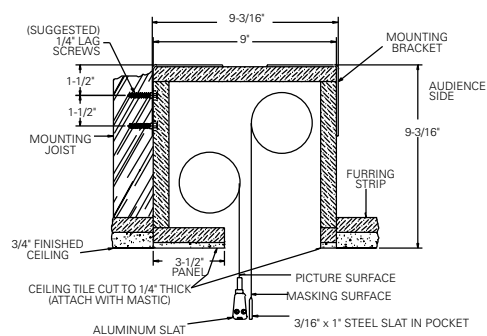

Offset mounting, recessed above ceiling. May be adapted for 3/4" ceiling, but cut to 1/4" thick under screen case and panel.

**METHOD C**

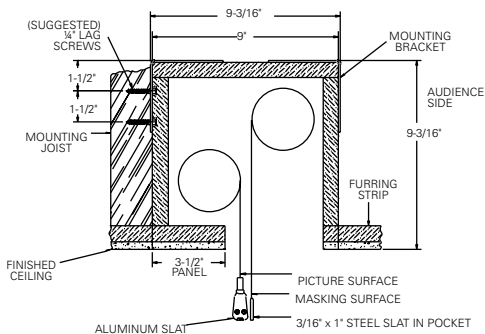

Offset mounting, recessed above ceiling. May be adapted for 1/4" paneling for ceiling.

**METHOD D**

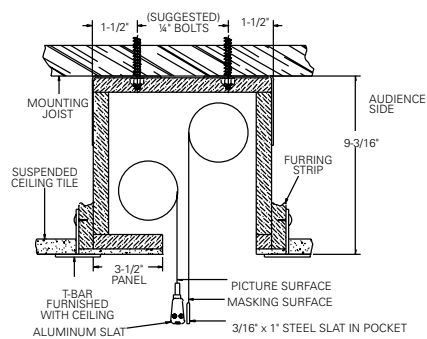

Flush mounting, recessed above ceiling. For use with dropped ceiling. May also be adapted for use with acoustical or other ceiling 3/4" thick but cut to 1/4" thick under screen case and panel.