

The Da-Lite Difference.

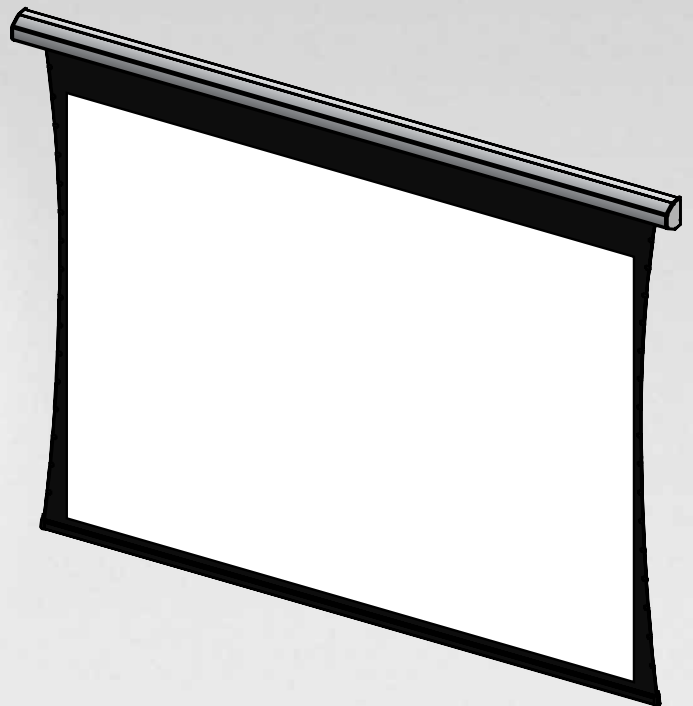

**Instruction Book for
TENSIONED LARGE COSMOPOLITAN®
ELECTROL®**



DA-LITE SCREEN COMPANY LLC

3100 North Detroit Street

Post Office Box 137

Warsaw, IN 46581-0137 USA

P 800-622-3737 / 574-267-8101

F 877-325-4832 / 574-267-7804

www.da-lite.com

e-mail: info@da-lite.com

IMPORTANT SAFETY INSTRUCTIONS

When using your video equipment, basic safety precautions should always be followed, including the following:

1. Read and understand all instructions before using.
2. Position the cord so that it will not be tripped over, pulled, or contact hot surfaces.
3. If an extension cord is necessary, a cord with a current rating at least equal to that of the appliance should be used. Cords rated for less amperage than the appliance may overheat.
4. To reduce the risk of electric shock, do not disassemble this appliance. Contact an authorized service dealer when repair work is required. Incorrect reassembly can cause electric shock when the appliance is used subsequently.
5. The use of an accessory attachment not recommended by the manufacturer may cause a risk of fire, electric shock, or injury to persons.

SAVE THESE INSTRUCTIONS

INSTALLATION

Carefully unpack screen and remove outer wrapping from case.

The slat retainer screws must be removed before installation. The slotted 1/4" hex screws fasten through the back of the case (at the bottom) into the slat bar. Orient the case with the slat down and then remove the screws. The case must remain in that orientation throughout the installation process to avoid fabric damage.

The Tensioned Large Cosmopolitan® Electrol® comes with brackets to allow for wall mount or ceiling mount installations. Procedures for each method are as follows:

Wall Mount

1. The wall mount bracket should be fastened to wall studs or some reinforcement within the wall. Concrete or brick walls require special fasteners and anchors.
2. The wall bracket has holes spaced at 16" and 24" to align with most wall studs.
3. The bracket must be level and plumb.
4. Keep in mind you will need at least 2-3/4" between the ceiling and the top of the wall mount bracket to be able to position the case on the bracket.
5. Mount the screen case on the wall bracket as shown in figure 1. Be sure the case is fully seated on the bracket. Tighten the stop screws against the wall bracket.

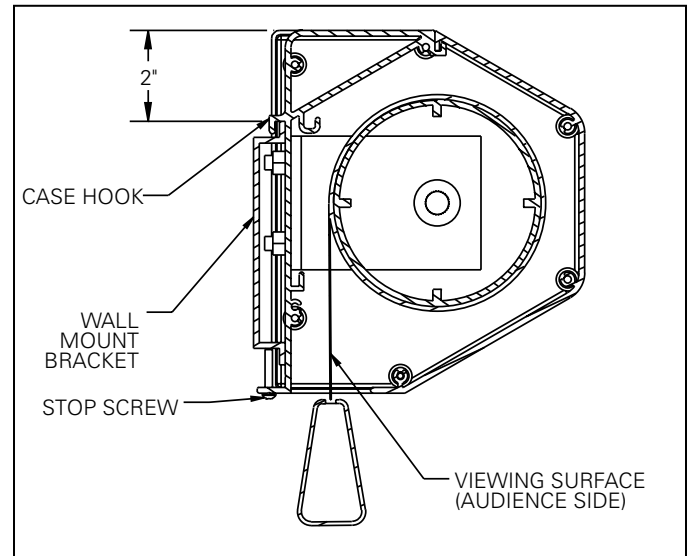

FIGURE 1

Ceiling Mount

1. Be sure the ceiling has adequate reinforcement to attach the screen brackets.
2. Attach the ceiling brackets to the wall mount bracket using the supplied 5/16" x 3/4" bolts, washers and nuts.
3. Position the ceiling bracket assembly on the ceiling and attach with 5/16" bolts (not supplied). The bolts should be long enough to pass through the drywall or ceiling tile and penetrate at least 1-1/2" into the reinforcement in the ceiling.
4. Mount the screen on the wall bracket as shown in figure 2. Be sure the case is fully seated on the bracket. Tighten the stop screws against the wall bracket.

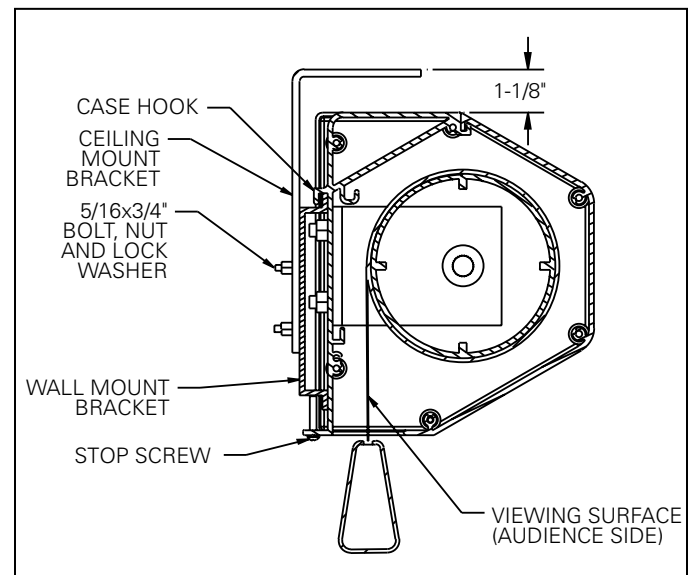

FIGURE 2

SCREEN ADJUSTMENT

Screen travel is stopped automatically in the down and up positions by the limit switches that are preset at the factory. No further adjustment is necessary.



CONTACT DA-LITE AT 800-622-3737 OR 574-267-8101 IF SCREEN MOTOR NEEDS ADJUSTMENT.

TENSIONED LARGE COSMOPOLITAN® ELECTROL® INSTALLATION FOR SCREENS WITHOUT A BUILT-IN LOW VOLTAGE CONTROL

Internal wiring has been completed at the factory. Installer must route power to the wall switch and to the junction box located on the left end of the screen case.

See wiring diagram below for wire connections.

NOTE: This screen can only be controlled by a single 120VAC or 240VAC wall switch. To use multiple switches, an optional low voltage control must be used.

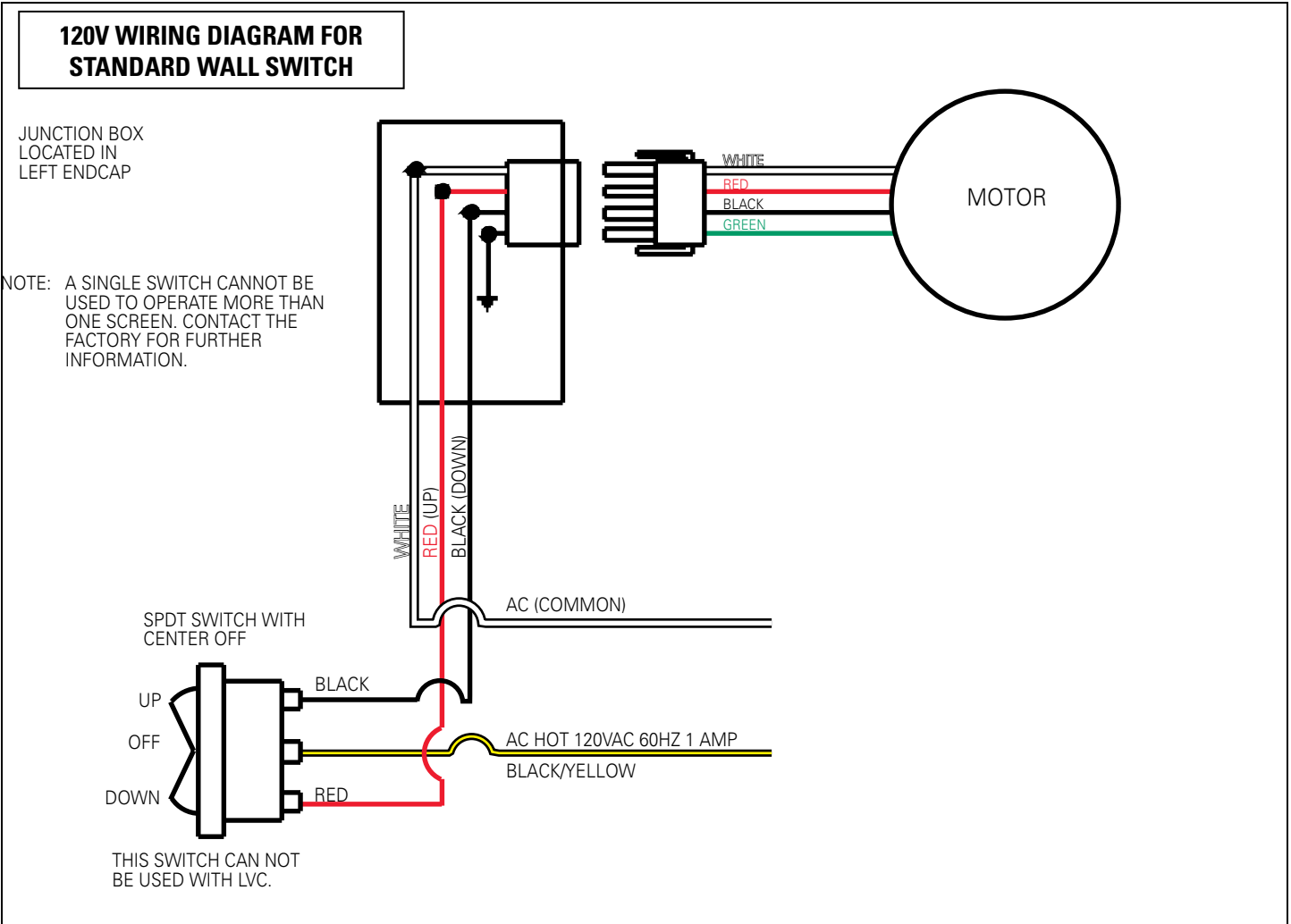

240 VOLT WIRING DIAGRAM FOR STANDARD WALL SWITCH:

Da-Lite offers two styles of 240 volt wall switches for standard operation. Please see wiring diagram in wall switch boxes included with screen.

TENSIONED LARGE COSMOPOLITAN® ELECTROL® INSTALLATION FOR SCREENS WITH A BUILT-IN LOW VOLTAGE CONTROL

120V WIRING DIAGRAM WITH OPTIONAL BUILT-IN LOW VOLTAGE CONTROL

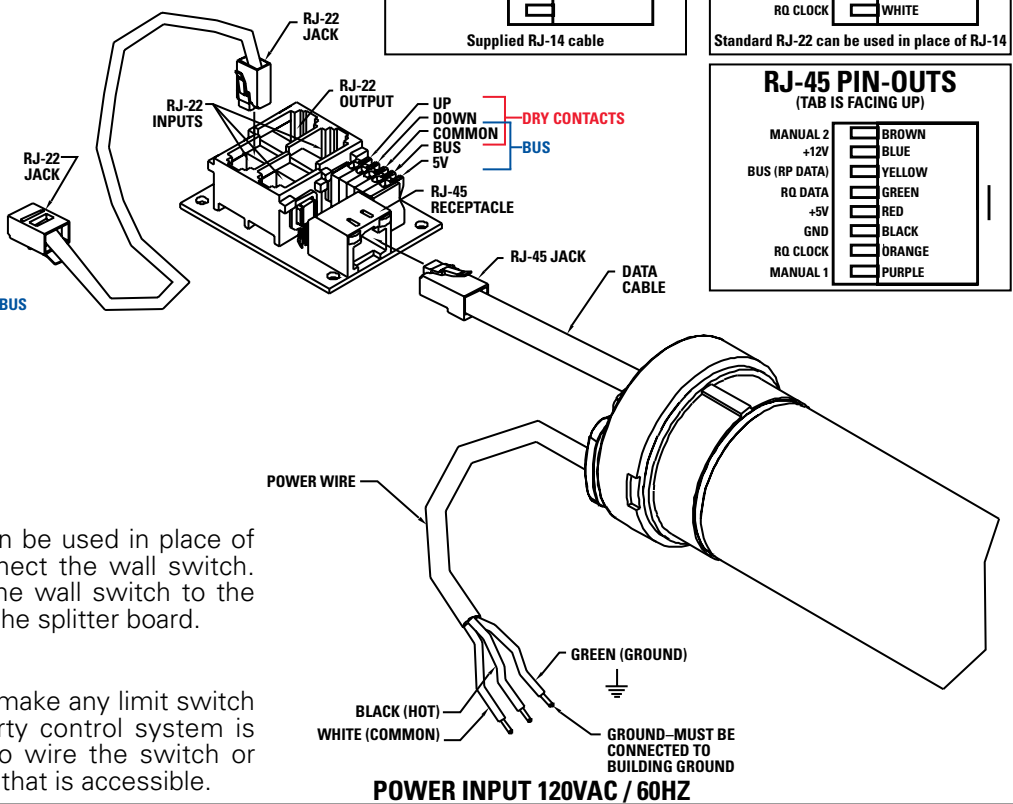
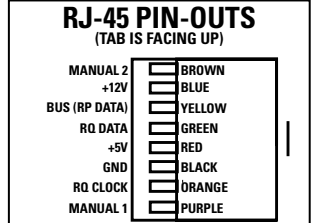
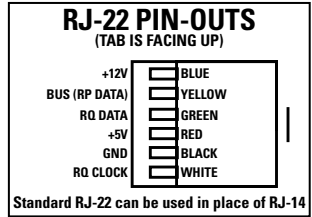
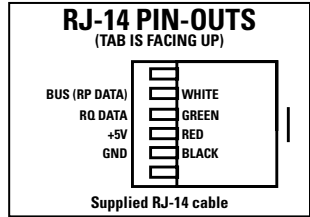
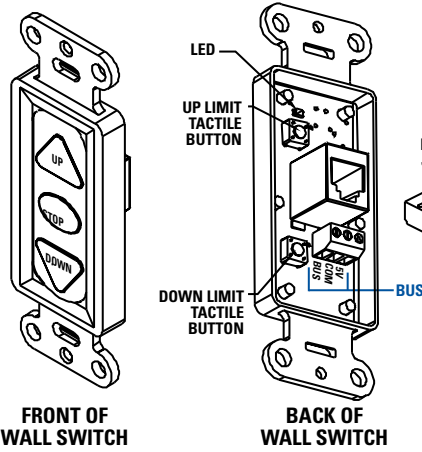

3-conductor 20-24 gauge wire can be used in place of the supplied RJ-14 cable to connect the wall switch. Connect the BUS terminals on the wall switch to the corresponding BUS terminals on the splitter board.

IMPORTANT NOTE:

The wall switch is REQUIRED to make any limit switch adjustments, EVEN if a third party control system is used. Therefore, it is advised to wire the switch or provide a 3-conductor connection that is accessible.

240V WIRING DIAGRAM WITH OPTIONAL BUILT-IN LOW VOLTAGE CONTROL

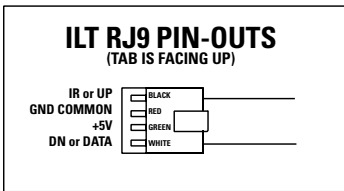
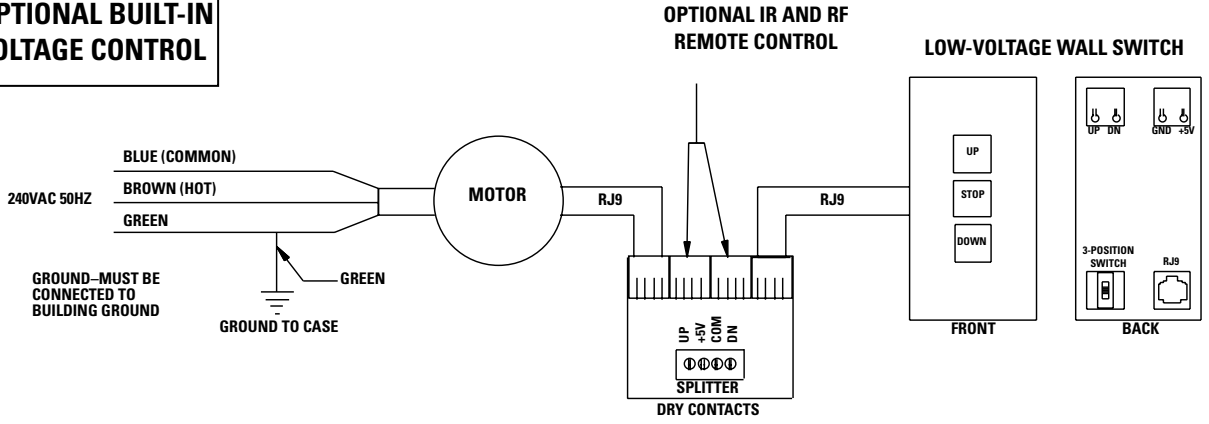

IMPORTANT NOTE: The wall switch is REQUIRED to make any limit switch adjustments, EVEN if a third party control system is used. Therefore, it is advised to wire the switch or provide a 4-conductor connection that is accessible.

TROUBLESHOOTING

Visit www.da-lite.com/products/product_videos.php to find installation and troubleshooting videos and tutorials. You will also find a link to Live Chat for interactive support and you can contact us by email at info@da-lite.com or by phone at (800) 622-3737 or (574) 267-8101 with any troubleshooting questions.

SYMPTOM	CAUSE	SOLUTION
1. Screen will not operate. Motor does not hum.	<p>(a) Blown fuse. (b) Tripped circuit breaker. (c) No power to operating switch or junction.</p> <p>Power at junction box</p> <p>(d) Thermal overload tripped. (e) Broken wire in the "down" or "up" position. (f) Defective motor, limit switch or capacitor. (g) Capacitor burned out.</p>	<p>(a) Replace fuse. (b) Reset circuit breaker. (c) Check above. Tighten all loose wire connections. Correct any improper connections. "Down" Position Check for power across black and white leads. "Up" Position Check for power across red and white leads.</p> <p>(d) Let motor cool down for 15 minutes. Try again. (e) Check for continuity. Cut off old splice and reconnect. (f) Replace motor assembly. NOTE: Motor is a sealed assembly. (g) Replace motor assembly.</p>
2. Incorrect stopping position in downward direction.	<p>(a) Lost roller wrap. (b) "Down" limit switch out of adjustment</p>	<p>(a) See instructions below. (b) Contact Da-Lite at 800-622-3737 or 574-267-8101</p>
3. Incorrect stopping position in upward direction.	<p>(a) Lost roller wrap. (b) "Up" limit switch out of adjustment</p>	<p>(a) See instructions below. (b) Contact Da-Lite at 800-622-3737 or 574-267-8101</p>
4. Noise. NOTE: Screen will operate with a low pitched hum.	<p>(a) Gear Noise.</p>	<p>(a) Replace motor assembly.</p>
5. Coasting.	<p>(a) Defective brake.</p>	<p>(a) Replace motor assembly.</p>

THIS PAGE IS INTENTIONALLY LEFT BLANK

**LIMITED ONE YEAR WARRANTY
ON DA-LITE PRESENTATION PRODUCTS**

Da-Lite Screen Company LLC warrants its products to the original purchaser only, to be free from defects in materials and workmanship for a period of one (1) year from the date of purchase by the original purchaser provided they are properly operated according to Da-Lite's instructions and are not damaged due to improper handling or treatment after shipment from the factory.

This warranty does not apply to equipment showing evidence of misuse, abuse or accidental damage, or which has been tampered with or repaired by a person other than authorized Da-Lite personnel.

Da-Lite's sole obligation under this warranty shall be to repair or to replace (at Da-Lite's option) the defective part of the merchandise. Returns for service should be made to your Da-Lite dealer. If it is necessary for the dealer to return the screen or part to Da-Lite, transportation expenses to and from Da-Lite are payable by the purchaser and Da-Lite is not responsible for damage in shipment. To protect yourself against damage or loss in transit, insure the product and prepay all transportation expenses.

THIS WARRANTY IS IN LIEU OF ALL OTHER WARRANTIES, EXPRESS OR IMPLIED, INCLUDING WARRANTIES AS TO FITNESS FOR USE AND MERCHANT ABILITY. Any implied warranties of fitness for use, or merchantability, that may be mandated by statute or rule of law are limited to the one (1) year warranty period. This warranty gives you specific legal rights, and you may also have other rights, which vary from state-to-state. **NO LIABILITY IS ASSUMED FOR EXPENSES OR DAMAGES RESULTING FROM INTERRUPTION IN OPERATION OF EQUIPMENT, OR FOR INCIDENTAL, DIRECT, OR CONSEQUENTIAL DAMAGES OF ANY NATURE.**

In the event that there is a defect in materials or workmanship of a Da-Lite product, you may contact our Sales Partners at PO Box 137, Warsaw, IN 46581-0137, (574) 267-8101, (800) 622-3737.

IMPORTANT: THIS WARRANTY SHALL NOT BE VALID AND DA-LITE SHALL NOT BE BOUND BY THIS WARRANTY IF THE PRODUCT IS NOT OPERATED IN ACCORDANCE WITH DA-LITE'S WRITTEN INSTRUCTIONS.

Keep your sales receipt to prove the date of purchase and your original ownership.