

MODEL: 1911 - 1912

- (2) Side frames RH/LH
- (1) Seat assembly
- (1) Back assembly
- (1) Medallion brace
- (1) Foot rest
- (1) Hardware pack

### STEP 1

Attach brace and foot rest into pockets on side frames using (6) 3" screws.

**Do not tighten screws until last step.**

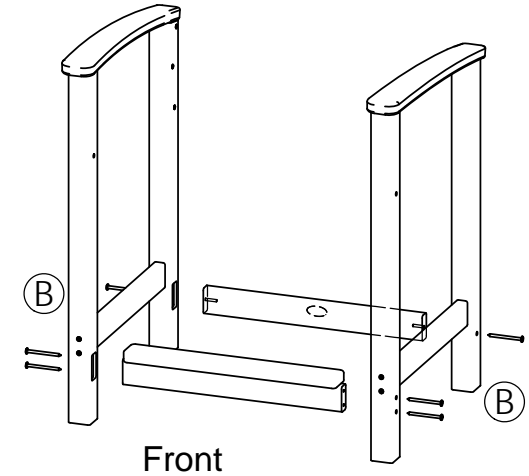

### STEP 2

Attach seat to side frames using (2) 3" screws for front leg and (2) 1-3/4 bolts for back leg.

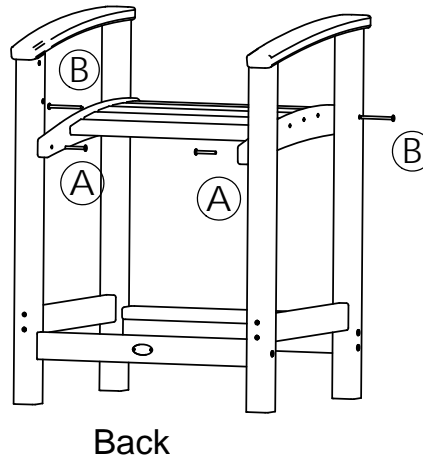

### STEP 3

Attach back assembly to side frames using (4) 1-3/4 bolts.

**Tighten all screws.**

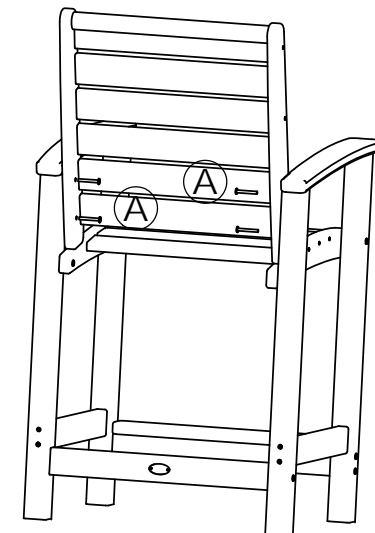

### TOOLS NEEDED

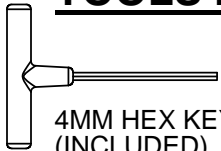

4MM HEX KEY, ALLEN, T-HANDLE  
(INCLUDED)

QTY	DESCRIPTION
6	A - 1/4-20 X 1-3/4 WAFER SHCS
8	B - .27 X 3 SOCKET WAFER "A"

A - 1/4-20 X 1-3/4 WAFER SHCS

6



B - .27 X 3 SOCKET WAFER "A"

8

