

Model: CLC23

- (1) Seat assembly
- (1) Back assembly
- (2) Sideframes
- (1) Top back rail
- (1) Seat support
- (1) Seat cushion
- (1) Back cushion
- (1) Hardware pack

Step 1

- Attach seat support to seat assembly using (2) 3" chair screws
- Attach back assembly to seat assembly using (2) 3" chair screws

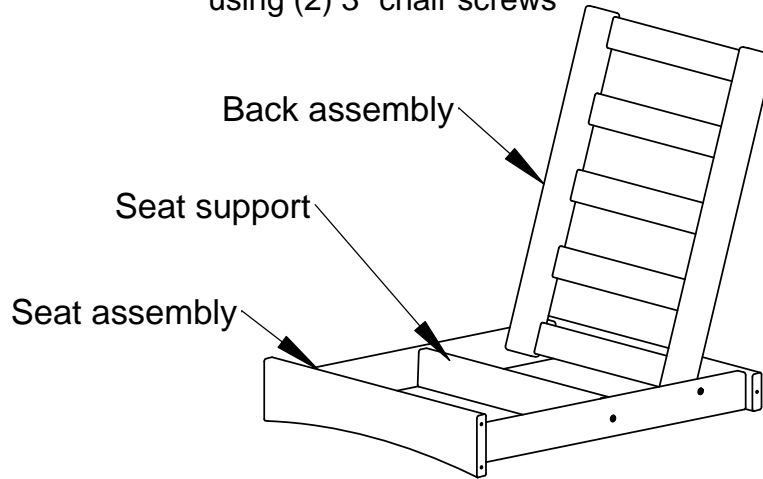

Step 2

- Lay the seat assembly on its side.
- Attach sideframe using (3) 3" chair screws

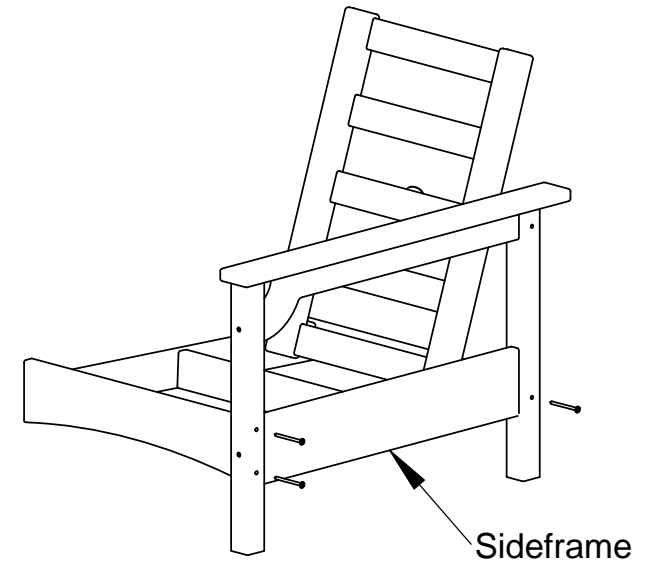

Step 3

- Repeat Step 2 on other side.

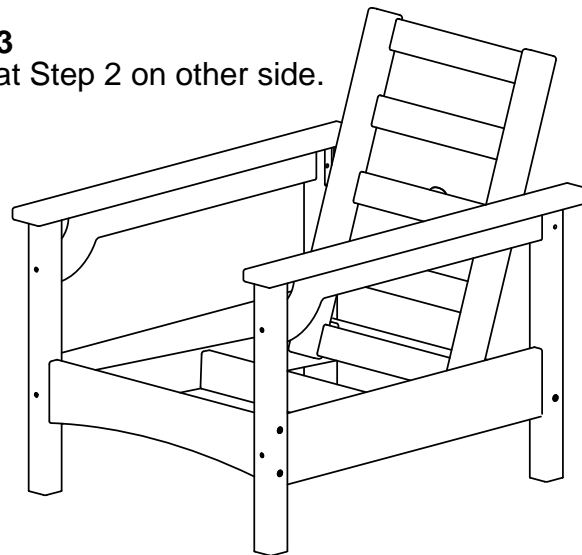

Step 4

- Attach top back rail to sideframes using (2) 3" chair screws
- Insert seat and back cushions

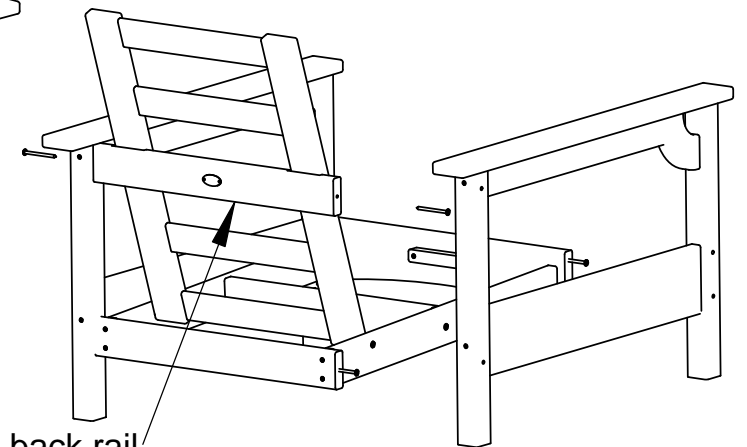

TOOLS NEEDED

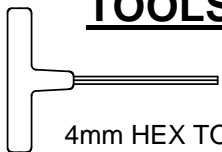

4mm HEX TOOL: INCLUDED

Qty.	Description
12	A - .27 X 3 SOCKET WAFER A

