

Model: CLC47 & CMC47
*CLC47 shown

- (2) Seat assembly
- (2) Back assembly
- (2) Seat support
- (2) Top rails
Right, Left
- (2) Sideframes
- (1) Front mid leg
- (1) Rear mid leg
- (2) Seat cushion
- (2) Back cushion
- (1) Hardware pack

TOOLS NEEDED

4mm" HEX KEY: INCLUDED
Phillips head screwdriver

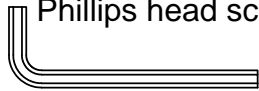

Step 1

- Attach seat support to seat assembly using (2) 3" chair screws
- Attach back assembly to seat assembly using (2) 3" chair screws
- Repeat until all seats and backs are assembled.

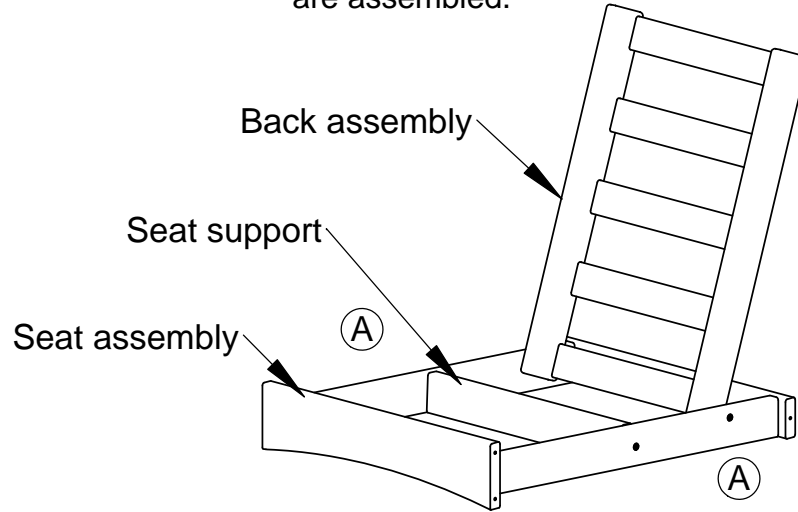

Step 2

- Lay a seat assembly on its side.
- Attach left sideframe to seat assembly and left top rail using (4) 3" chair screws

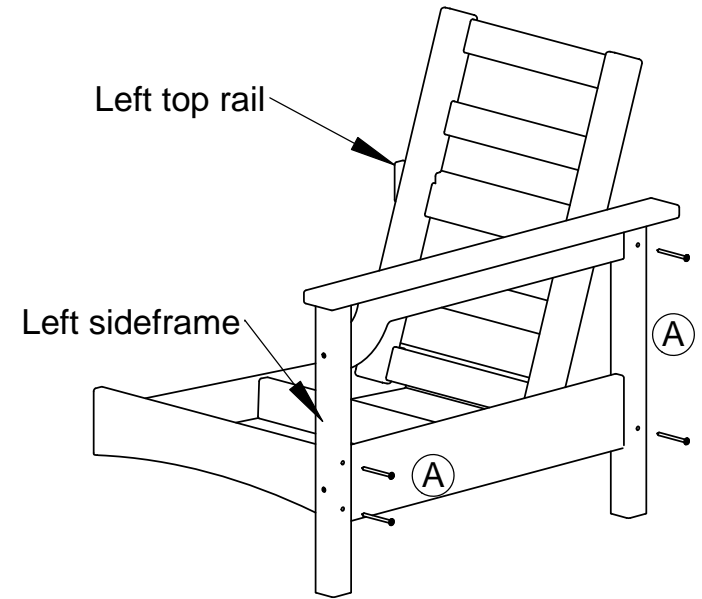

Step 3

- Lay another seat assembly on its side.
- Attach right sideframe to seat assembly and right top rail using (4) 3" chair screws

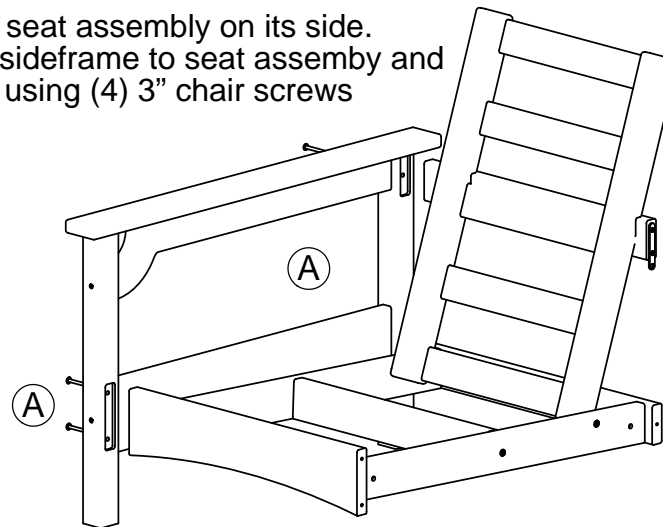

See page 2

Qty.	Description
16	A - 14 X 3 SOCKET WAFER "B"
3	B - 1/4-20 x 1/2" BARREL NUT
1	C - 1/4-20 X 1-1/2 WAFER SHCS
2	D - 1/4-20 X 3-1/4 WAFER SHCS

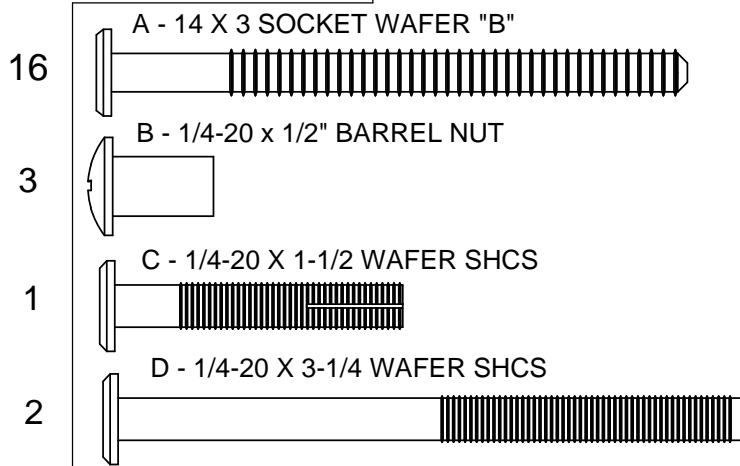

Model: CLC47 & CMC47

Step 5

Attach all sections together using

B - (3) capnuts

C - (1) 1 1/2" chair bolt

D - (2) 3 1/4" chair bolts

Step 4
Fit all sections together with mid legs

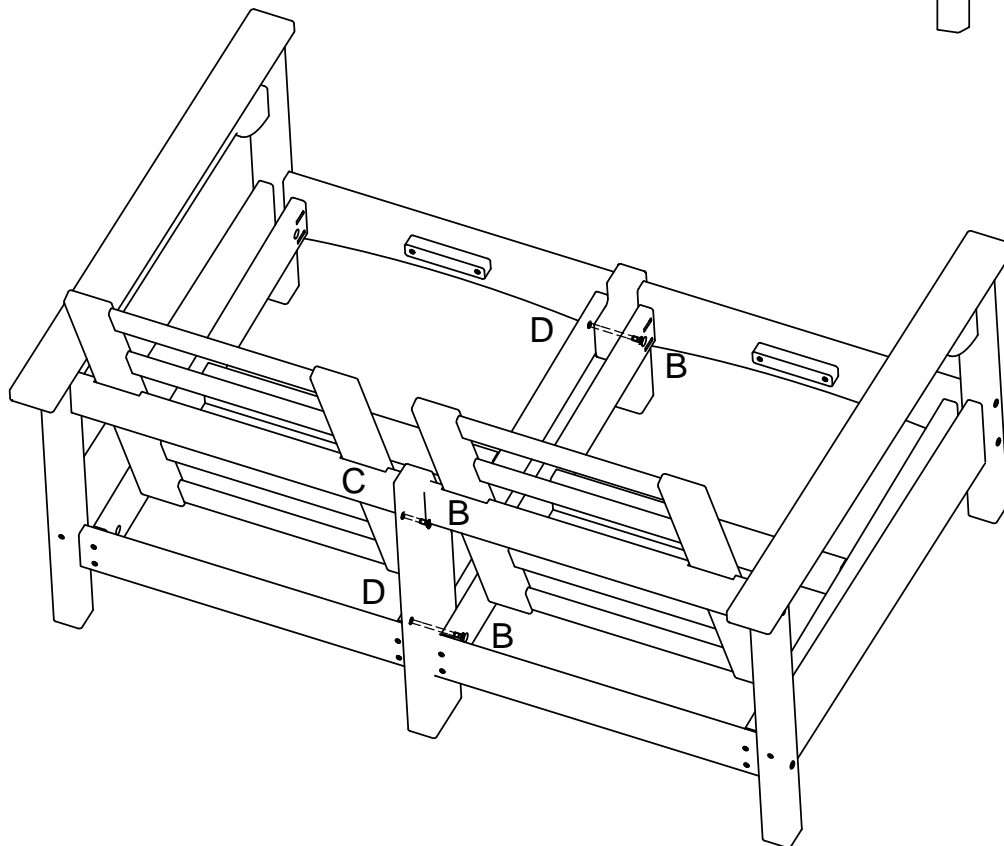
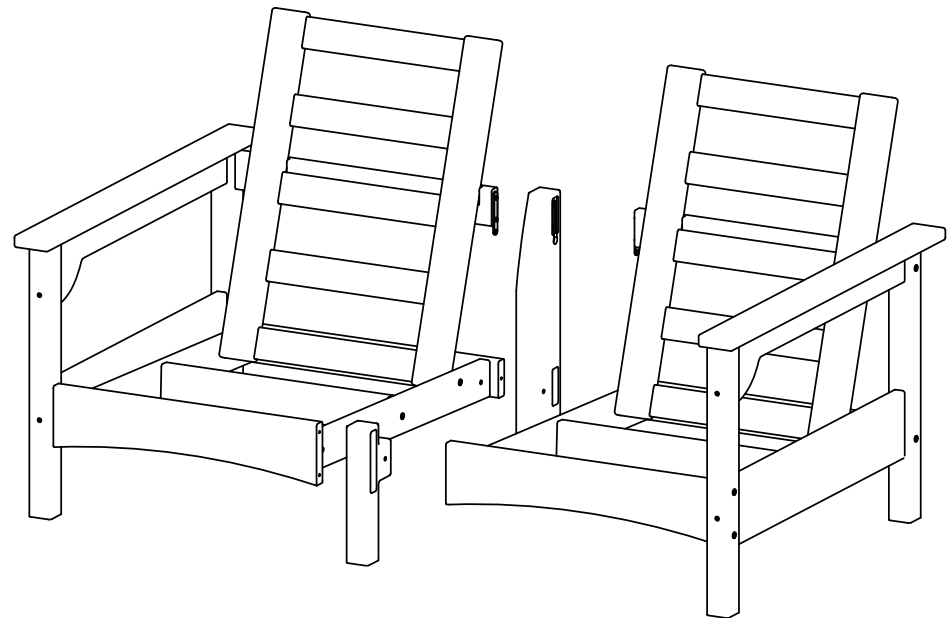

CMC47

