

Model: CLC71 & CMC71  
\*CLC71 shown

- (3) Seat assembly
- (3) Back assembly
- (3) Seat support
- (3) Top rails  
Right, Center, Left
- (2) Sideframes
- (2) Front mid leg
- (2) Rear mid leg
- (3) Seat cushion
- (3) Back cushion
- (1) Hardware pack

## TOOLS NEEDED

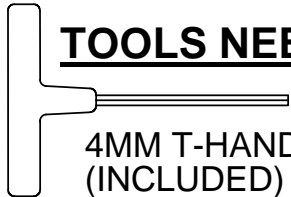

4MM T-HANDLE HEX KEY  
(INCLUDED)

-Phillips head screwdriver

### Step 1

- Attach seat support to seat assembly using (2) 3" chair screws
- Attach back assembly to seat assembly using (2) 3" chair screws
- Repeat until all seats and backs are assembled.

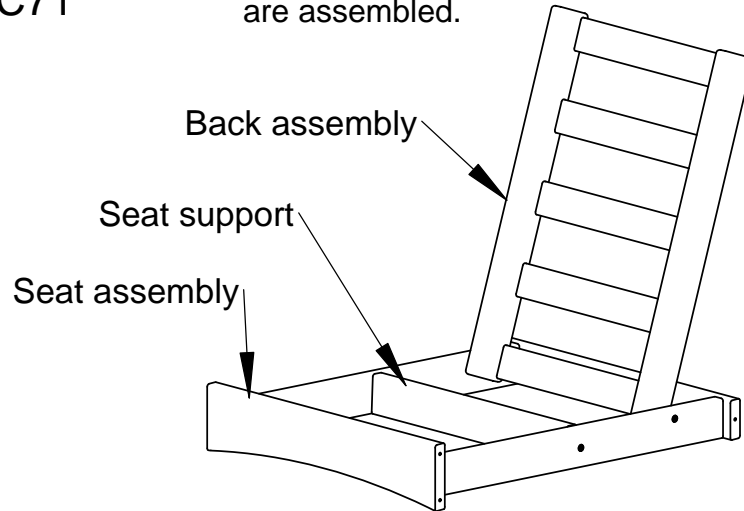

### Step 2

- Lay a seat assembly on its side.
- Attach left sideframe to seat assembly and left top rail using (4) 3" chair screws

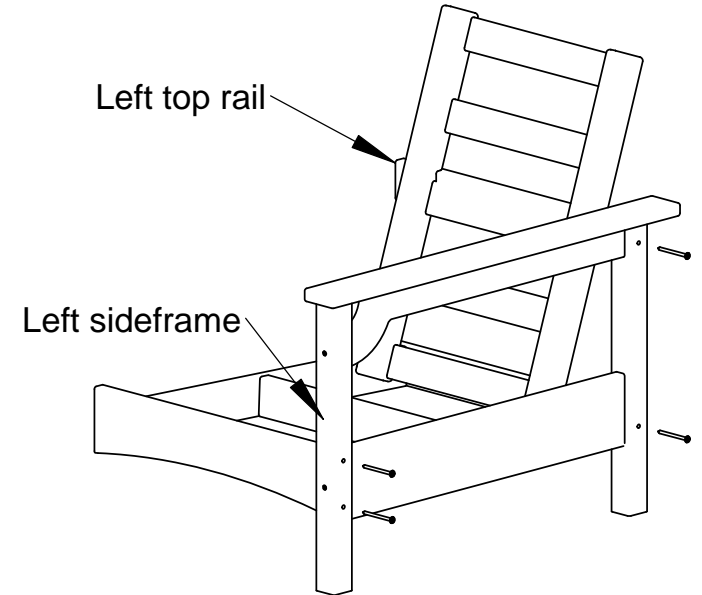

### Step 3

- Lay another seat assembly on its side.
- Attach right sideframe to seat assembly and right top rail using (4) 3" chair screws

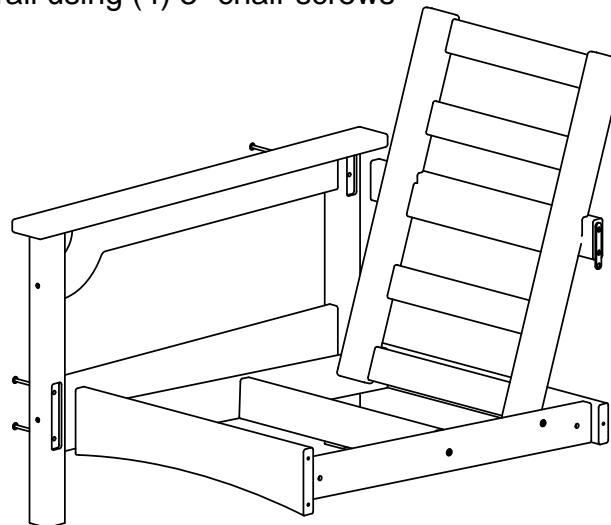

**See page 2**

Qty.	Description
20	A - 3" Chair screw
6	B - capnut
2	C - 1 1/2" chair bolt
4	D - 3 1/4" chair bolt

Model: CLC71 & CMC71

**Step 4**  
Fit all sections together with mid legs

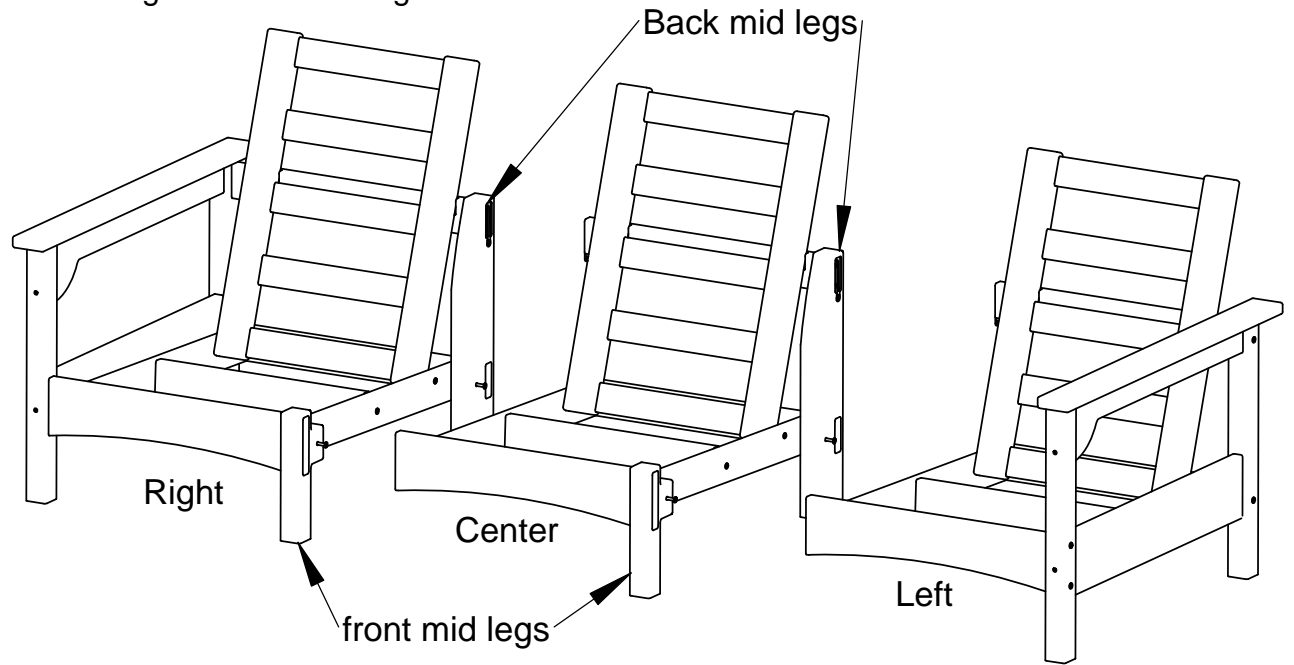

**Step 5**  
Attach all sections together using  
B - (6) capnuts  
C - (2) 1 1/2" chair bolts  
D - (4) 3 1/4" chair bolts

