



Intelligent Design™

MODEL: NCW2280

STEP 1

Attach front legs to seat assembly using (4) 1-3/4" bolts

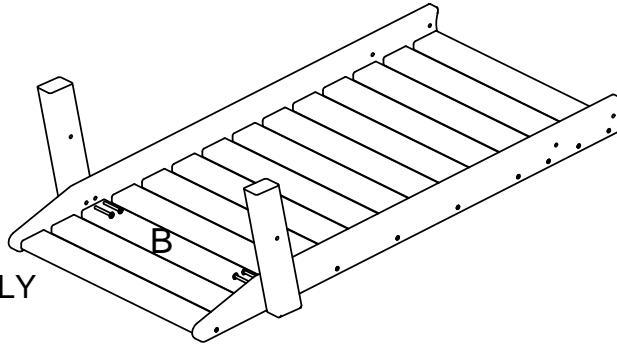

STEP 2

Attach sideframes to both the seat and back assemblies using (6) 1-3/4" bolts

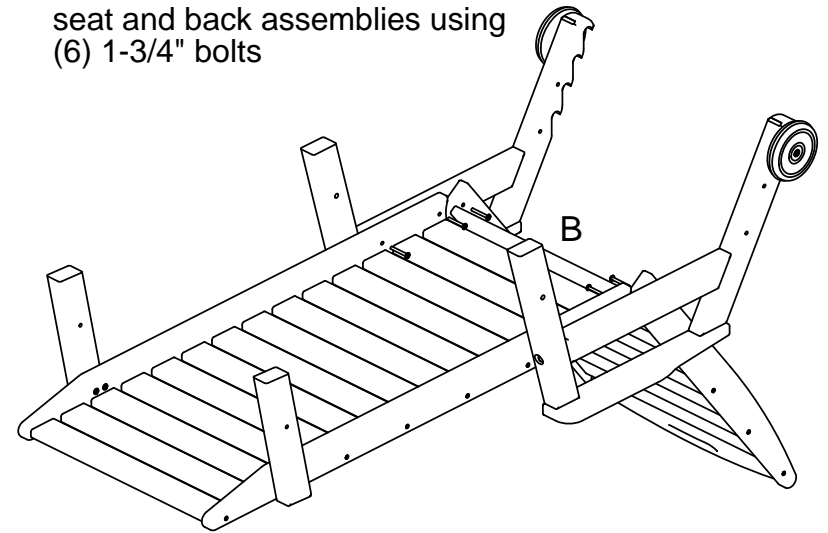

STEP 4

Attach stretchers to the legs using (8) 2-1/4" bolts

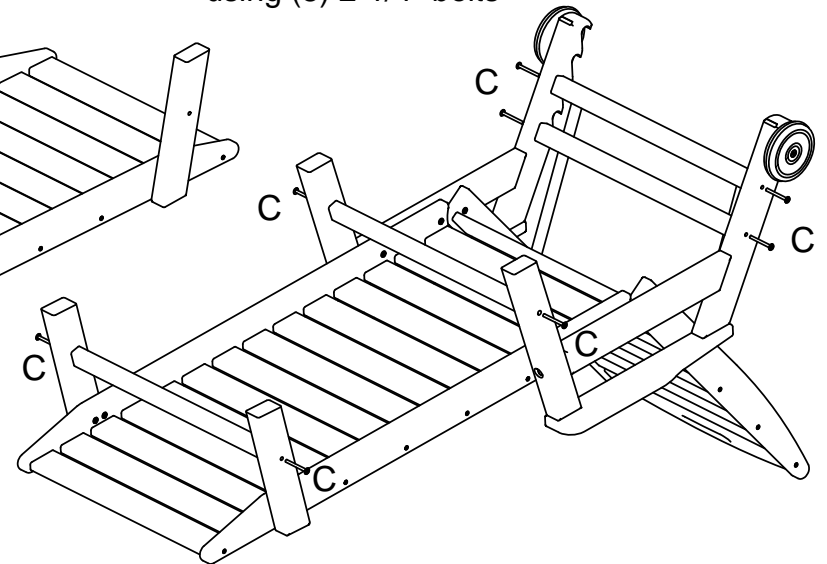

STEP 3

Attach metal brace to the back assembly using (2) 1-1/2" bolts

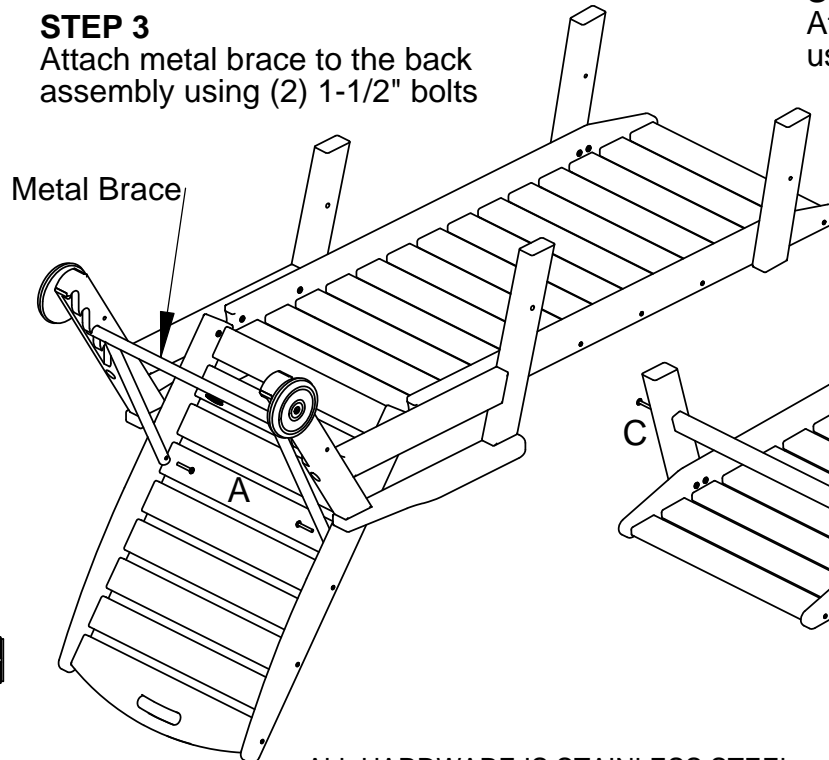

- ___ (1) HARDWARE PACK
- ___ (2) SIDEFAME
- ___ (1) SEAT
- ___ (1) BACK
- ___ (2) STRETCHER
- ___ (1) STRETCHER ASSEMBLY
- ___ (2) FRONT LEG
- ___ (1) METAL BRACE

TOOLS NEEDED

4mm" HEX KEY: INCLUDED

QTY	DESCRIPTION
-----	-------------

2	A-1/4-20 X 1-1/2 WAFER SHCS
10	B-1/4-20 X 1-3/4 WAFER SHCS
8	C-1/4-20 X 2-1/4 WAFER SHCS