

BC4013R0TX-ESPRESSO
BC401400TX-WHITE
BC401500TX-BLACK
"CHELMSFORD" SHOE BENCH
Assembly Instructions



Southern
ENTERPRISES

For assistance with assembly contact:
Southern Enterprises, Inc.
Customer Service 1-800-633-5096
service@seidal.com
www.seidal.com

PO#12862

Max seat load: 250 lb.

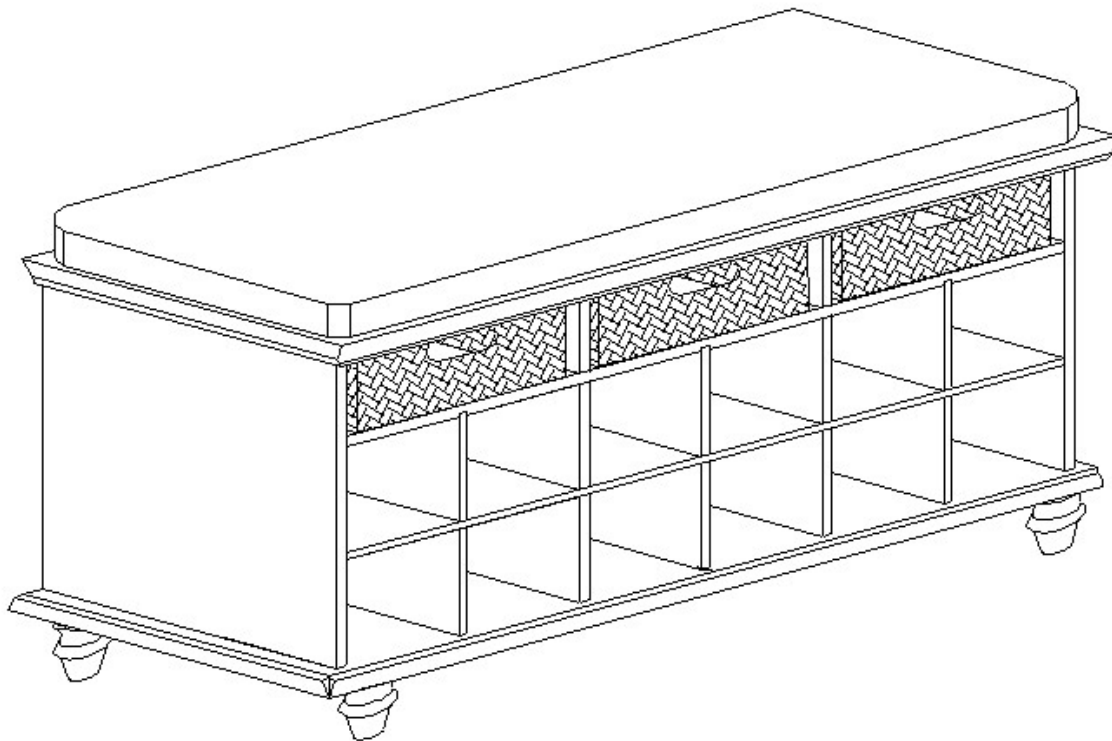

"CHELMSFORD" SHOE BENCH Parts List

Please review all parts and hardware before disposing of any packaging.

Call Customer Service if missing hardware.

Using a screw that is too long will cause damage. Before beginning assembly, separate each type of screw. Carefully study the screw diagrams below.

You may receive extra hardware with your unit.

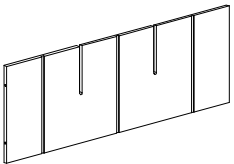
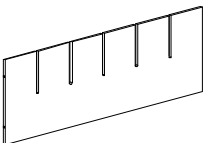
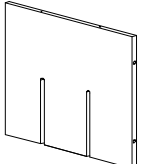
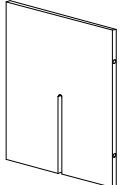
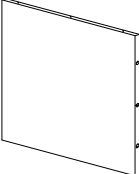
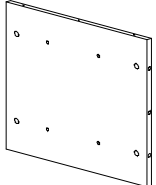
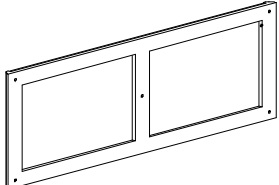
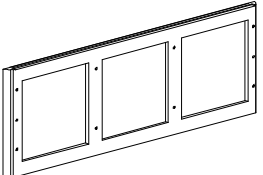
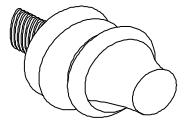
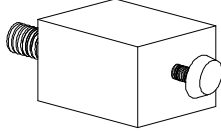
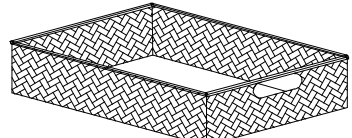
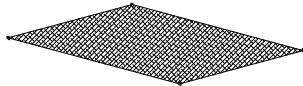
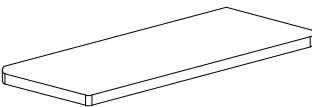
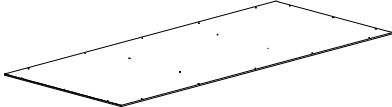
<p>A</p>  <p>Quantity of 1</p> <p>First Shelf Panel</p>	<p>B</p>  <p>Quantity of 1</p> <p>Second Shelf Panel</p>
<p>C</p>  <p>Quantity of 2</p> <p>Big Divider Panel</p>	<p>D</p>  <p>Quantity of 3</p> <p>Small Divider Panel</p>
<p>E</p>  <p>Quantity of 1</p> <p>Right Side Panel</p>	<p>F</p>  <p>Quantity of 1</p> <p>Left Side Panel</p>
<p>G</p>  <p>Quantity of 1</p> <p>Bottom Panel</p>	<p>H</p>  <p>Quantity of 1</p> <p>Top Panel</p>
<p>I</p>  <p>Quantity of 4</p> <p>Leg</p>	<p>J</p>  <p>Quantity of 1</p> <p>Center Support Leg</p>
<p>K</p>  <p>Quantity of 3</p> <p>Basket Frame</p>	<p>L</p>  <p>Quantity of 3</p> <p>Basket Bottom</p>
<p>M</p>  <p>Quantity of 1</p> <p>Cushion</p>	<p>N</p>  <p>Quantity of 1</p> <p>Back Panel</p>

Care and Cleaning Instructions:

Before using, wipe with a clean, dry cloth. Periodically apply furniture wax to renew the finish . Avoid rubbing or scratching the surface with rough or abrasive objects.

For replacement parts or questions, please

Call Customer Service at 1-800-633-5096 please callManufacturer for assistance, questions or Parts.



Assembly Tool Required
No.2 Phillips Screwdriver (Not Included)



"CHELMSFORD" SHOE BENCH

Parts List

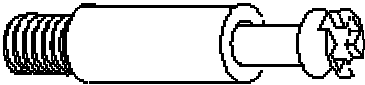
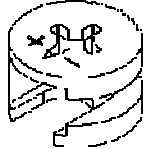
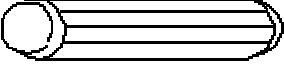
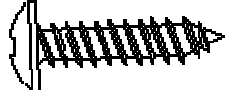
Please review all parts and hardware before disposing of any packaging.
 Call Customer Service if missing hardware.
 Using a screw that is too long will cause damage. Before beginning assembly,
 separate each type of screw. Carefully study the screw diagrams below.
 You may receive extra hardware with your unit.

<p>1</p> <p style="text-align: right;">Quantity of 8</p>  <p>Cam Bolt</p>	<p>2</p> <p style="text-align: right;">Quantity of 8</p>  <p>Cam Lock</p>
<p>3</p> <p style="text-align: right;">Quantity of 26</p>  <p>Wood Dowel (Ø5*30mm)</p>	<p>4</p> <p style="text-align: right;">Quantity of 22</p>  <p>Wood Screw (Ø3*12MM)</p>
<p>5</p> <p style="text-align: right;">Quantity Of 8</p>  <p>COTTON MAT</p>	
<p>Care and Cleaning Instructions: Before using, wipe with a clean, dry cloth. Periodically apply furniture wax to renew the finish . Avoid rubbing or scratching the surface with rough or abrasive objects.</p>	<p>For replacement parts or questions, please Call Customer Service at 1-800-633-5096 please call Manufacturer for assistance, questions or Parts.</p>
<p style="text-align: center;">Assembly Tool Required No.2 Phillips Screwdriver (Not Included)</p>	

"CHELMSFORD" SHOE BENCH Assembly Instructions

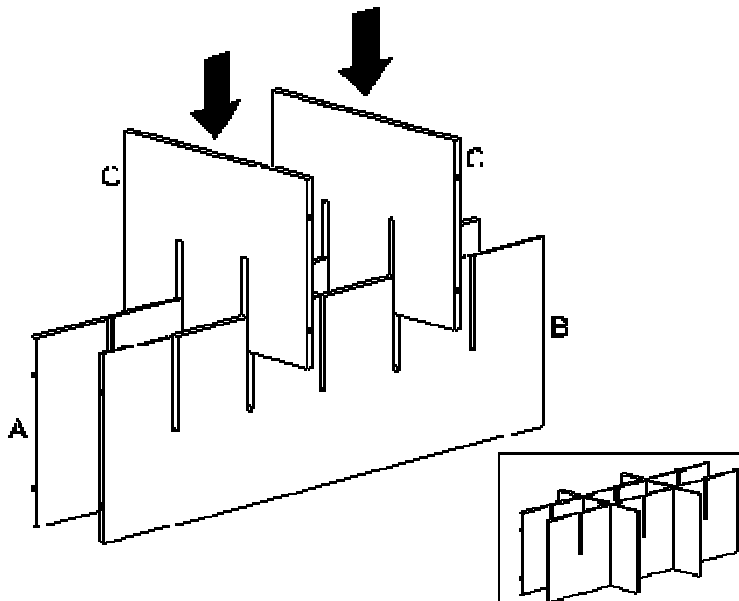

Figure 1

Assembly Instructions:

Wood may scratch easily, Be careful when assembling. Do not scratch.

Step 1 Unpack and lay parts on clean, padded surface like carpet or blanket. Check that you have all parts indicated on the front page.

Step 2 Attach the big divider Panel (C) to the Shelf Panel (A,B) as figure shown.

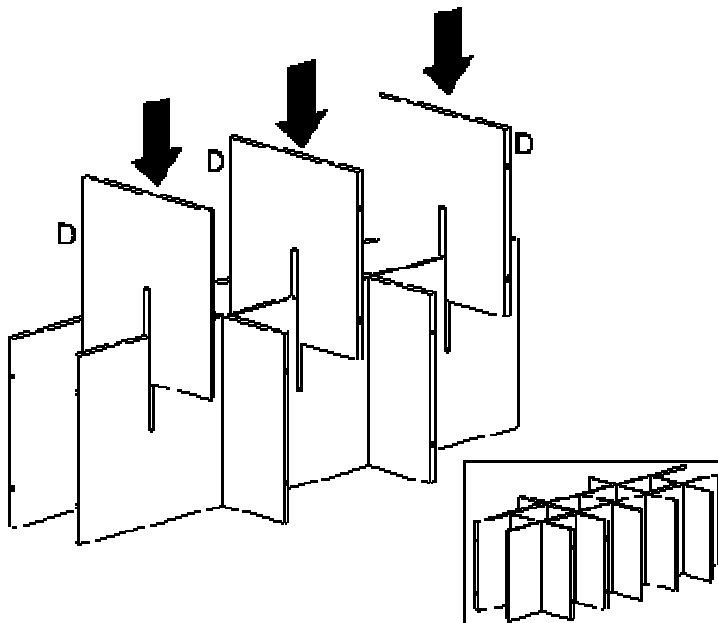

Figure 2

Attach the small Divider Panel (D) to the Shelf Panel (A,B) as figure shown.

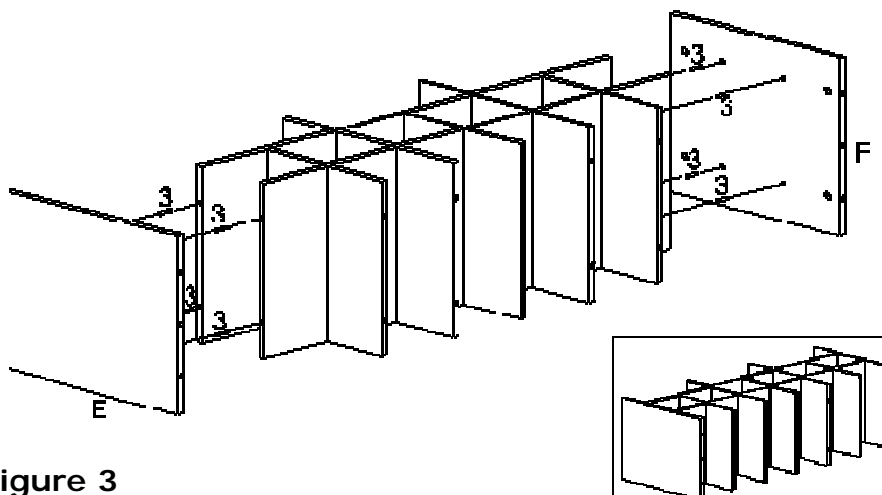

Figure 3

Connect the Left/Right Side Panel (E,F) with 8pcs Wood Dowels (3).

"CHELMSFORD" SHOE BENCH Assembly Instructions

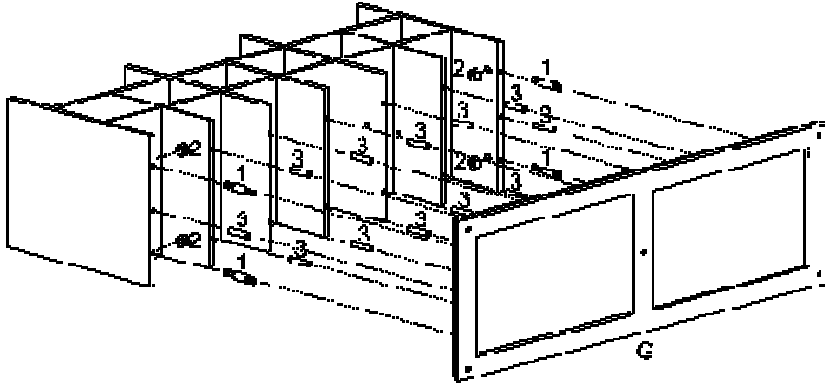

Figure 4

Connect the Bottom panel (G), with 12pcs Wood Dowels(3),4pcs Cam Bolts (1) and Cam Locks (2).

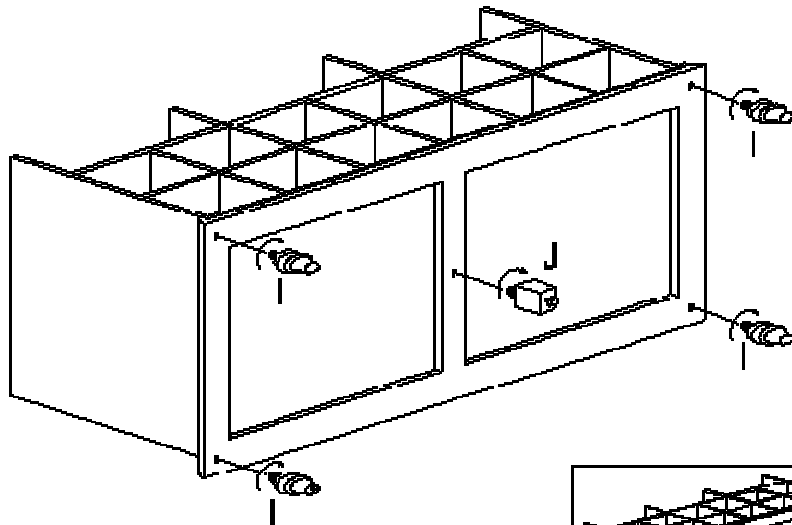

Figure 5

Attach the Legs(I) and Center Support Leg (J) to the Bottom Frame (G).

Please remove plastic off legs before attaching them to bottom panel

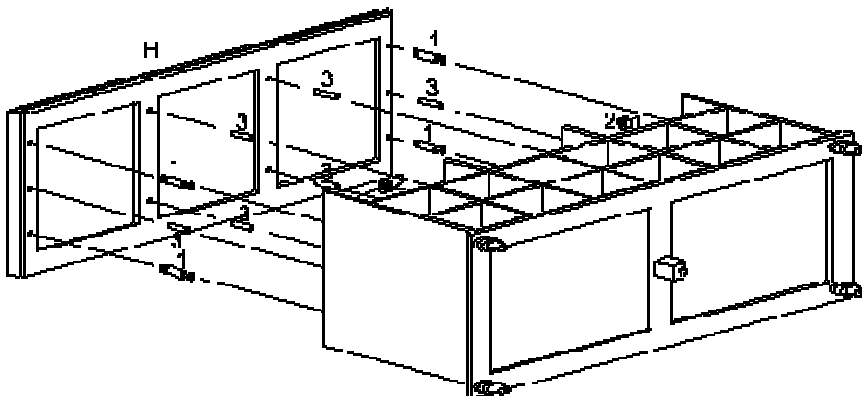

Figure 6

Connect the Top Panel (H) to the assembled unit with 6pcs Wood Dowels (3),4pcs Cam Bolts (1) and 4pcs Cam Locks (2).

"CHELMSFORD" SHOE BENCH Assembly Instructions

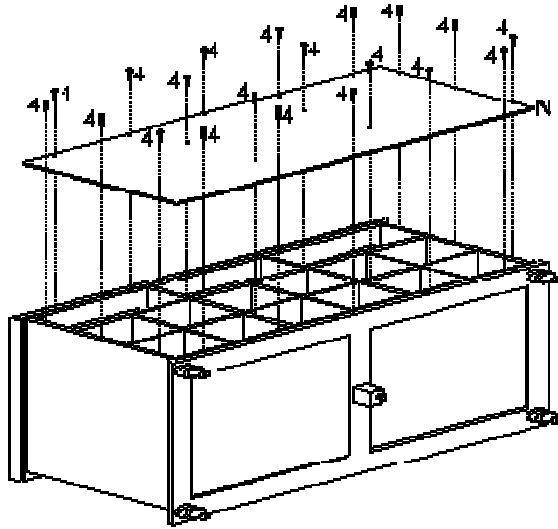

Figure 7

Connect the Back Panel (N) to the assembled unit with 20pcs Wood Screws (4).

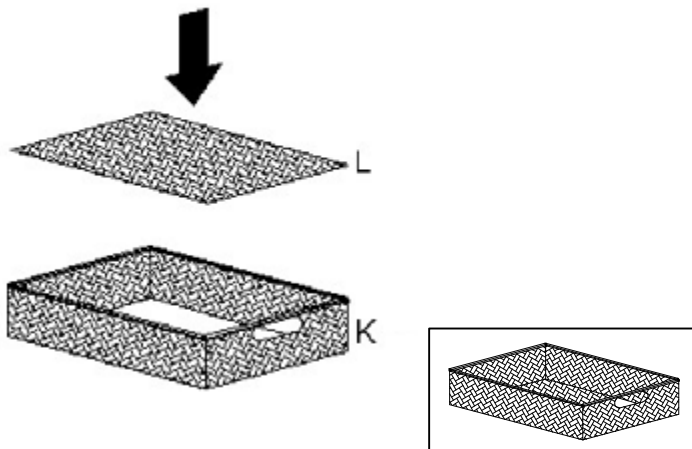

Figure 8

Attach the wicker bottom (L) to wicker frame (K)

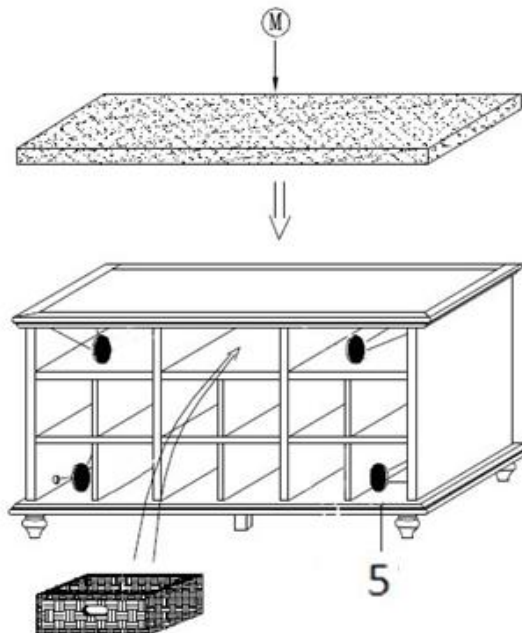

Figure 9

Cover cam-locks (4) with cotton mats (5) provided.
Insert wicker baskets.
Put the cushion (M) onto top panel (H).

Parts Replacement Form

Customer Information

Name _____

Address _____

City/State/Zip Code _____

Phone Number _____

Please indicate where you purchased this item: Store/Website/Catalog

Please indicate color/size/style number:

Style No	Parts Letter	Parts Description	Quantity Needed
_____	_____	_____	_____
_____	_____	_____	_____
_____	_____	_____	_____

Please immediately examine this product carefully. Any request for missing parts or damage replacement must be received within 90 days of your receipt of the product. Replacement, if available, will be honored within this time frame. Parts will not be available for items arriving fully assembled. We do not recommend modifying product(s) and we are not responsible for any damages due to product modification(s). If damages or missing parts are not reported within 90 days of your receipt, we are under no obligation to provide parts or replacement merchandise.

Please contact Southern Enterprises at 800-633-5096 or in Dallas 972-869-0111/ 9am – 4pm Mon-Fri Central time if you have product issues or email us at service@seidal.com. Please ask for customer service representative for issues involving damages or replacement parts. Please ask for technical assistance representative for any issues with product and assembly/construction.

Please contact the retailer that you purchased from for returns.



Southern
ENTERPRISES

Customer Service 1-800-633-5096
service@seidal.com
Southern Enterprises, Inc.
600 Freeport Parkway, Suite 200
Coppell, Texas 75019