

HO8808R0TX—Mahogany finish

HO880900TX –Cherry finish

Mission Computer Desk-Mahogany
Assembly Instruction



For assistance with assembly contact:
Southern Enterprises Inc.
Customer Service 1-800-633-5096
service@seidal.com
www.seidal.com



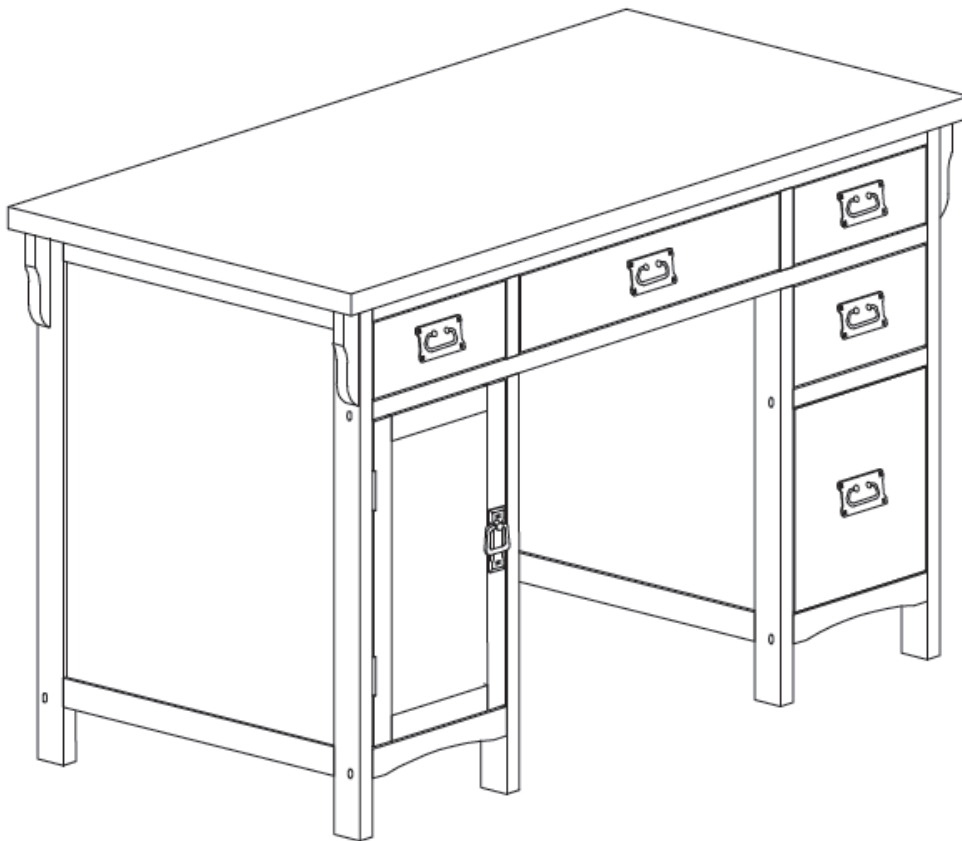





PO#11693

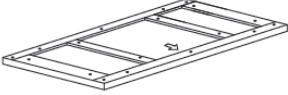
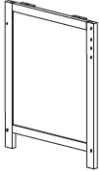
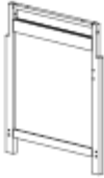



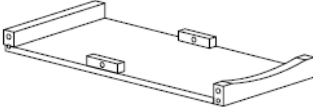
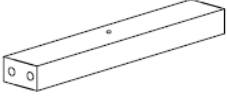

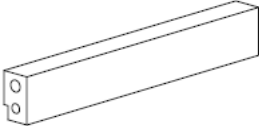
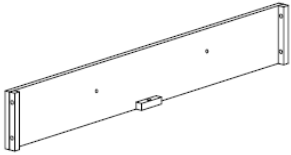
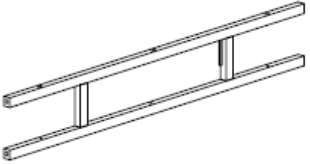
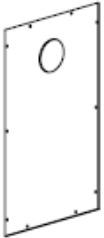
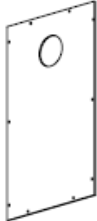



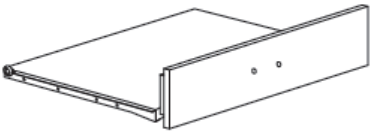
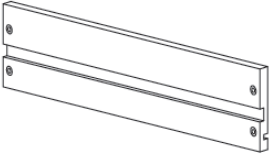
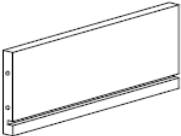
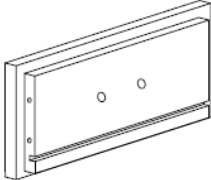

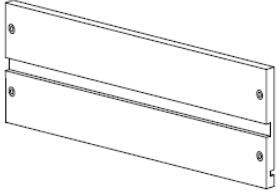
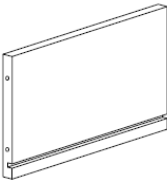
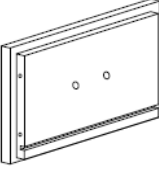
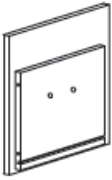

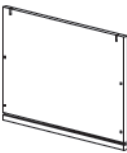
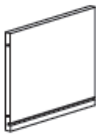





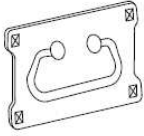

HO8808R0TX—Mahogany finish / HO880900TX –Cherry finish

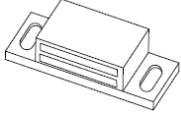
Mission Computer Desk-Mahogany Parts List

Please review all parts and hardware before disposing of any packaging. Call Customer Service if missing hardware. Do not return to store/retailer. Using a screw that is too long will cause damage. Before beginning assembly, separate each type of screw. Carefully study the screw diagrams below. You may receive extra hardware with your unit.

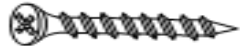
| | | |
|---|--|---|
| <p>A 1pc</p>  <p>Wood Top</p> | <p>B 1pc</p>  <p>Left Panel</p> | <p>C 1pc</p>  <p>Middle Left Panel</p> |
| <p>D 1pc</p>  <p>Middle Right Panel</p> | <p>E 1pc</p>  <p>Right Panel</p> | <p>F 4pcs</p>  <p>Decor Panel</p> |
| <p>G 1pc</p>  <p>Bottom Panel</p> | <p>H 1pc</p>  <p>Across Panel</p> | <p>I 1pc</p>  <p>Front Low Panel</p> |
| <p>J 1pc</p>  <p>Back Across Panel</p> | <p>K 1pc</p>  <p>Back Frame</p> | <p>L 1pc</p>  <p>Front frame</p> |
| <p>M1 1pc</p>  <p>Right Back Panel</p> | <p>M2 1pc</p>  <p>Left Back Panel</p> | <p>N 1pc</p>  <p>Door</p> |

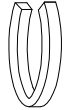
| | | |
|--|--|---|
| <p>O 1pc</p>  <p>Keypad Board</p> | <p>P 4pcs</p>  <p>Drawer Side Panel</p> | <p>Q 2pcs</p>  <p>Drawer Back Panel</p> |
| <p>R 2pcs</p>  <p>Drawer Front Panel</p> | <p>S 3pcs</p>  <p>Drawer Shelf</p> | <p>T 2pcs</p>  <p>Drawer Side Panel</p> |
| <p>U 1pc</p>  <p>Drawer Back Panel</p> | <p>V 1pc</p>  <p>Drawer Front Panel</p> | <p>W 1pc</p>  <p>Drawer Front Panel</p> |
| <p>X 1pc</p>  <p>Drawer Left Side Panel</p> | <p>Y 1pc</p>  <p>Drawer Right Side Panel</p> | <p>Z 1pc</p>  <p>Drawer Back Panel</p> |
| <p>AA 1pc</p>  <p>Drawer Shelf</p> | | |
| <p>1 40pcs</p>  <p>Bolt 1/4"x 1-1/4"</p> | <p>2 14pcs</p>  <p>Wood Dowel 5/16" x1-1/4"</p> | <p>3 22pcs</p>  <p>SCREW 1/8"x1/2"</p> |

| | | |
|---|---|--|
| <p>4</p>  <p>1pc</p> <p>Knob</p> | <p>5</p>  <p>5pcs</p> <p>Knob</p> | <p>6</p>  <p>12pcs</p> <p>Bolts 5/32"x 3/4"</p> |
| <p>7</p>  <p>4pcs</p> <p>Screw 1/8"x1/2"</p> | <p>8</p>  <p>1pc</p> <p>Magnet</p> | <p>9</p>  <p>3pcs</p> <p>Plastic Drawer Stopper</p> |
| <p>10</p>  <p>3pcs</p> <p>Screw 1/8"x1/2"</p> | <p>11</p>  <p>2pcs</p> <p>Aluminum</p> | <p>12</p>  <p>32pcs</p> <p>Screw 5/32"x1"</p> |
| <p>13</p>  <p>10pcs</p> <p>Wood Cap</p> | <p>14</p>  <p>1pc</p> <p>Wrench 1/4"</p> | <p>15</p>  <p>16pcs</p> <p>Spring washer 1/4"</p> |
| <p>16</p>  <p>16pcs</p> <p>Flat washer 1/4"x1/2"</p> | | |

Care and Cleaning Instructions:

Before using, wipe with a clean, dry cloth. Periodically apply furniture wax to renew the finish. Avoid rubbing or scratching the surface with rough or abrasive objects.

For replacement parts or questions, please call Customer Service at 1-800-633-5096. Do not return product to store. Please call manufacturer for assistance, questions or parts.

**Assembly Tool Required
No.2 Phillips Screwdriver**



Computer Desk-Mahogany Assembly Instructions

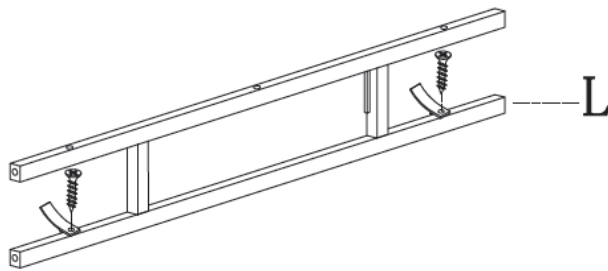
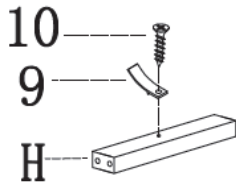

Step 1:

PLEASE DO NOT OVER-TIGHTEN CAMBOLTS. PLEASE STOP WHEN YOU FEEL TIGHT

Attach 3pcs Plastic Drawer Stopper (9) to the Across Panel/ Front frame (H/L) with 3pcs Wood Screw (10) ,

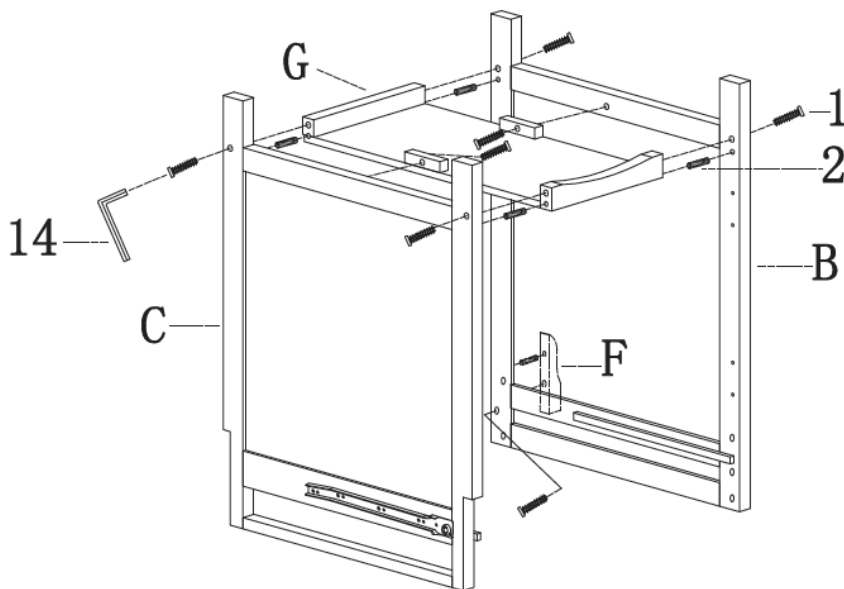

Step 2:

Connect the Decor Panel (F)with the left side panel(B)by using 1pcs wood Dowel(2) and 1pcs bolt (1), tighten by using the Wrench(14) .

Connect the left/Middle side panel(B/C)with the bottom panel(G)by using 4pcs wood Dowel(2) and 7pcs bolt (1),tighten by using the Wrench(14) as shown.

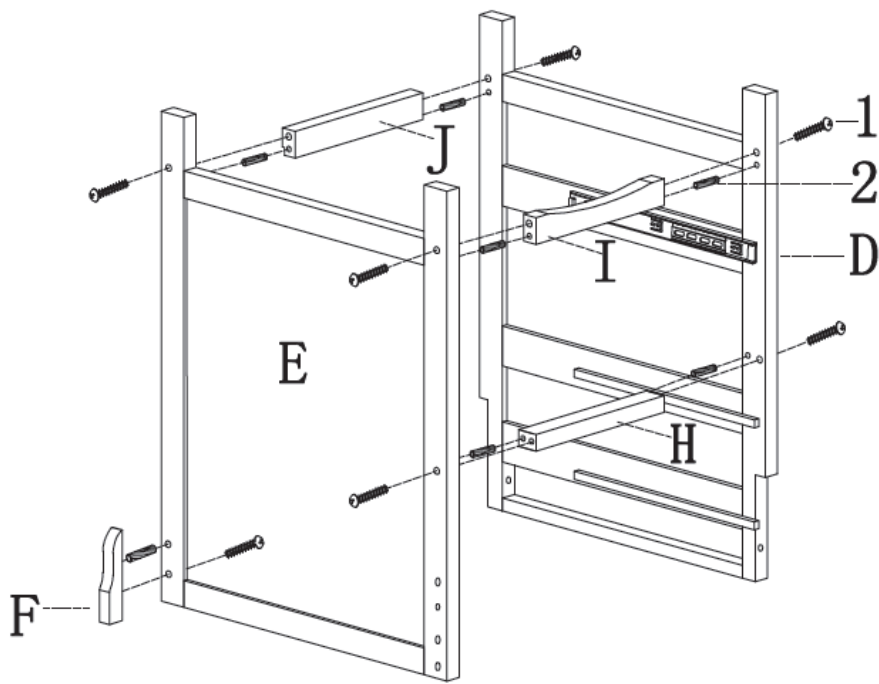

Step 3:

Connect the Decor Panel (F) with the Right side panel (E) by using 1 pcs wood Dowel (2) and 1 pcs bolt (1), tighten by using the Wrench (14)

Connect the Right /Middle side panel (D/E) with the Across Panel (H/I/J) by using 6 pcs wood Dowel (2) and 6 pcs bolt (1), tighten by using the Wrench (14) as shown.

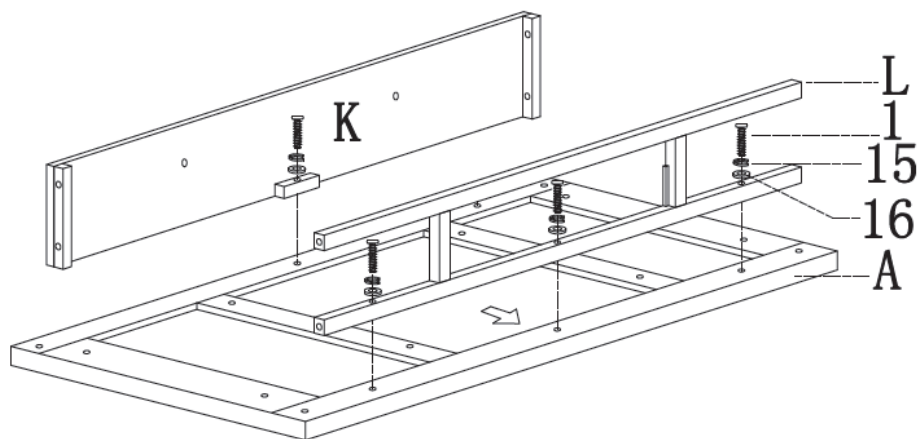

Step 4:

Connect the Wood Top (A), the Back Frame (K) and Drawer Frame (L) with 4 pcs Bolt (1) and 4 pcs Spring washer (15) 4 pcs Flat washer (16) Wrench (14) as shown..

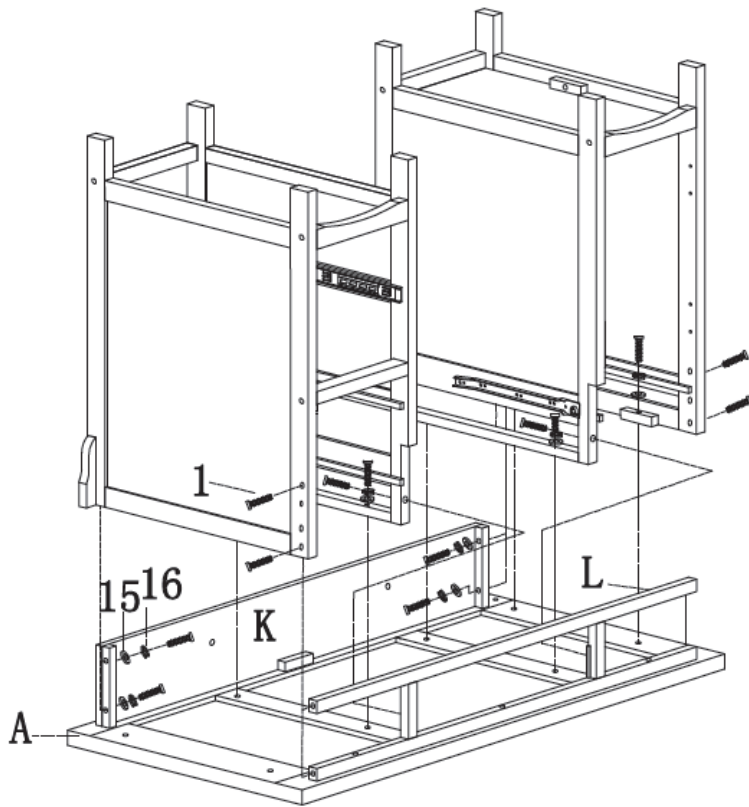

Step 5:

Attach the unit assembled at step2/step3 to the unit assembled at step4 with 16pcs bolt (1) and 16pcs Spring washer (15) 16pcs Flat washer (16) by using the Wrench(14) as shown.

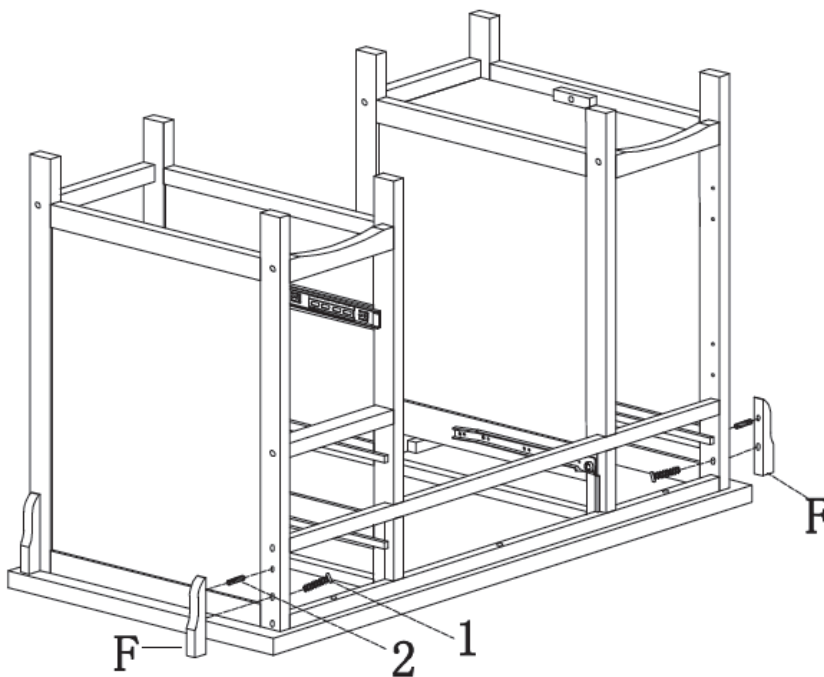

Step6:

Connect the Decor Panel (F)with the left /Right side panel(B/E)by using 2pcs wood Dowel(2) and 2pcs bolt (1), tighten by using the Wrench(14)

Step7:

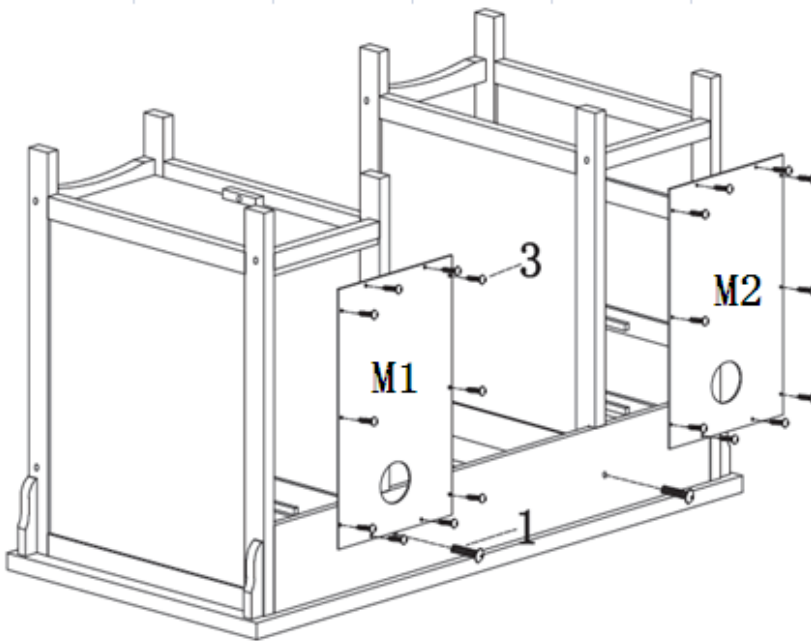

Connect the 1pc Right Back Panel (M1) and 1pc Left Back panel (M2) to the unit with 20pcs Wood Screw (3).

Connect the Back Frame (K) with the Right/Left Partition Board (B/E) by using 2pcs Bolt (1), tighten by using the Wrench(14)

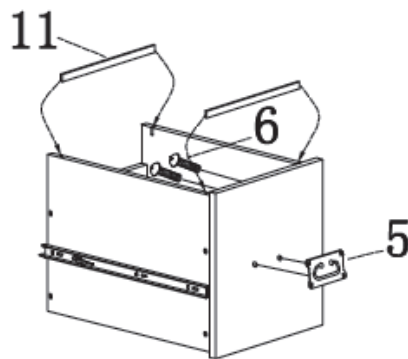
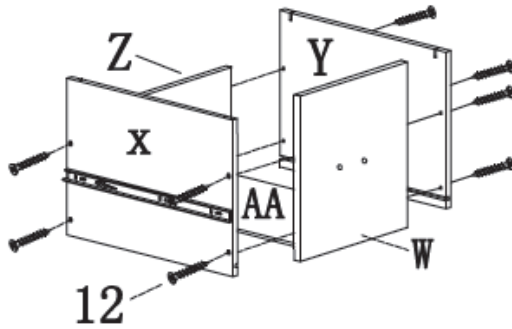

Step8:

Assemble the Medium drawer (W/X/Y/Z/AA) by using 8pcs Wood Screws (12).

Fix the Handle (5) to the Drawer Front Panel (W) with 2pcs Bolt (6) by using the Screwdriver.

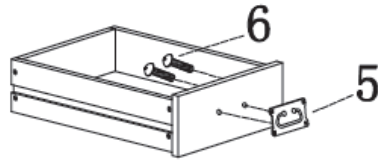
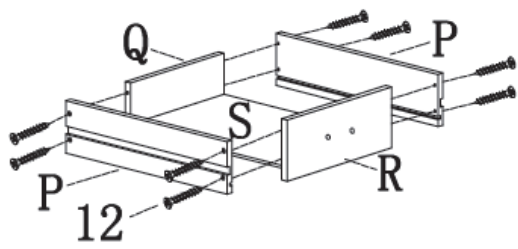

Step9:

Assemble the Medium drawer (P/Q/R/S) by using 8pcs Wood Screws (12).

Fix the Handle (5) to the Drawer Front Panel (R) with 2pcs Bolt (6) by using the Screwdriver.

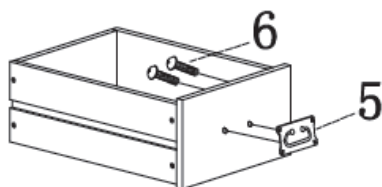
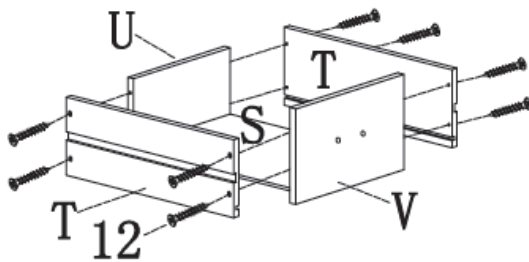

Step10:

Assemble the Medium drawer (T/V/U/S) by using 8pcs Wood Screws (12).

Fix the Handle (5) to the Drawer Front Panel (V) with 2pcs Bolt (6) by using the Screwdriver.

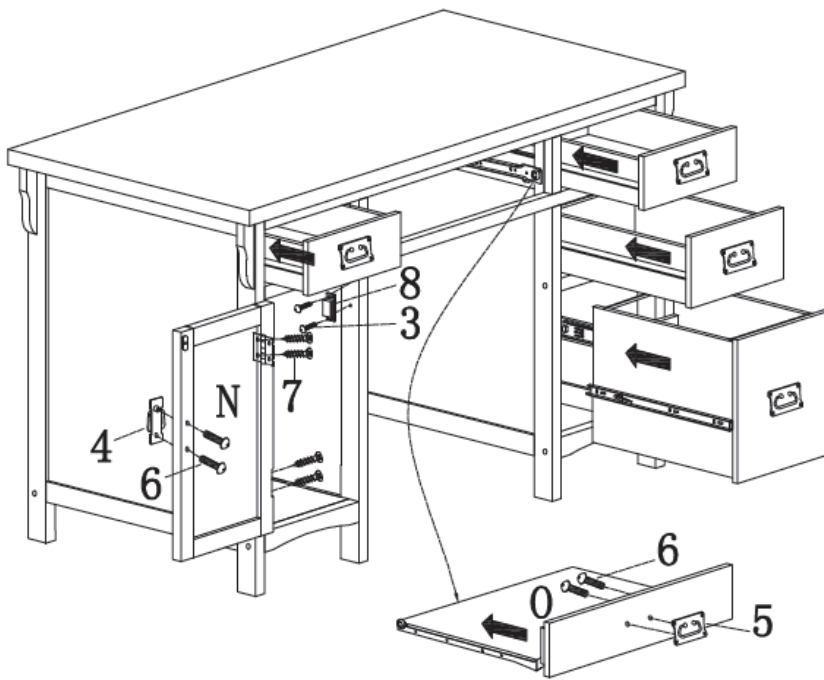

Step11:

Fix the Magnet (8) to the Left Partition Board (C) with 2pcs Wood Screw (3) by using the Screwdriver.

Fix the Handle (4/5) to the Door/ Keypad Board (N/O) with 4pcs Bolt (6) by using the Screwdriver.

Connect the Door (N) with the Left Side Panel (B) by using 4pcs Wood Screw (7), tighten the screws with screwdriver.

Put the Drawers into the right position.

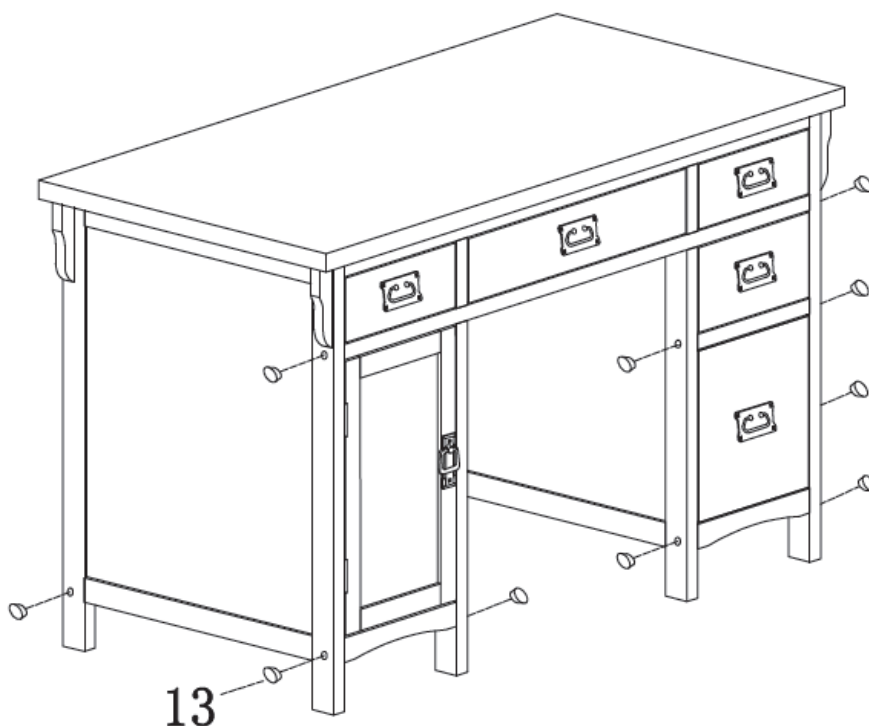

Step12:

Insert 10pcs Wood Cap (13) to the Left and Right Side Panel to Cover the holes.

Parts Replacement Form

Customer Information

Name

Address

City/State/Zip Code

Phone Number

Please indicate where you purchased this item: Store/Website/Catalog

Please indicate color/size/style number:

| Style No | Parts Letter | Parts Description | Quantity Needed |
|----------|--------------|-------------------|-----------------|
|----------|--------------|-------------------|-----------------|

Please immediately examine this product carefully. Any request for missing parts or damage replacement must be received within 90 days of your receipt of the product. Replacement, if available, will be honored within this time frame. Parts will not be available for items arriving fully assembled. We do not recommend modifying product(s) and we are not responsible for any damages due to product modification(s). If damages or missing parts are not reported within 90 days of your receipt, we are under no obligation to

provide parts or replacement merchandise.

Please contact Southern Enterprises at 800-633-5096 or in Dallas 972-869-0111/ 9am – 4pm Mon-Fri Central time if you have product issues or email us at service@seidal.com. Please ask for customer service representative for issues involving damages or replacement parts. Please ask for technical assistance representative for any issues with product and assembly/construction.

Please contact the retailer that you purchased from for returns.



Customer Service 1-800-633-5096

service@seidal.com

Southern Enterprises, Inc.

600 Freeport Parkway, Suite 200

Coppell, Texas 75019