



COMMERCIAL PLASTIC SEATS

MODEL 293SS



- ELONGATED SEAT, OPEN FRONT WITH COVER
- SOLID PLASTIC
- SELF-SUSTAINING, CHROME-PLATED BRASS HINGE

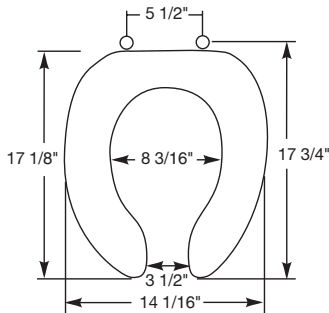

Seats shall be No. 293SS as manufactured by Church Seats. Seats shall be heavy weight and injection molded of solid plastic. Seats shall be open front with cover for elongated bowl and feature large molded-in bumpers. Self-sustaining, chrome-plated brass hinges with 300 Series stainless steel pintles. Color to be white.

Ring thickness is 3/4"
Ring thickness including the bumper is 1-1/16"
Height of the seat with cover is 2-1/4 "

