

# BDI SEQUEL LATERAL FILE CABINET

6015 6016 6017

## ASSEMBLY INSTRUCTIONS

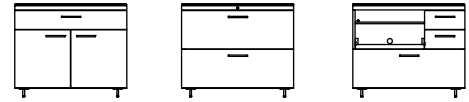

BDIUSA.COM CUSTOMERSERVICE@BDIUSA.COM

### Component List

**A** - 4mm Hex L-Wrench  
x 1

**B** - 1/4-20 x 18mm  
Machine Screw x 16  
Black Color

**C** - 1/4-20 x 22mm  
Machine Screw x 3  
Chrome Color

**D** - Rubber Stem Bumper  
x 2

**E** - M4 x 25mm  
Machine Screw  
6015 x 4

**F** - M4 x 37mm  
Machine Screw  
6015 x 2  
6016 x 4  
6017 x 6

**G** - Handles  
6015 x 3  
6016 x 2  
6017 x 3

**H** - Large File Folder  
Brackets  
6016 x 2  
6017 x 1

**I** - Small File Folder  
Brackets  
6016 x 4  
6017 x 2

**J** - Glass Top x 1

**K** - Cabinet x 1

**L** - Base Legs x 2

**M** - Shelf Pins  
6015 x 8  
6017 x 4

SEQUEL LATERAL FILE CABINETS are engineered for easy assembly. Carefully follow this procedure to prevent any damage.

### Placement and Maintenance

SEQUEL LATERAL FILE CABINETS are designed for indoor use on level floors. Clean glass with glass cleaner, and wood veneer with a moist cloth.

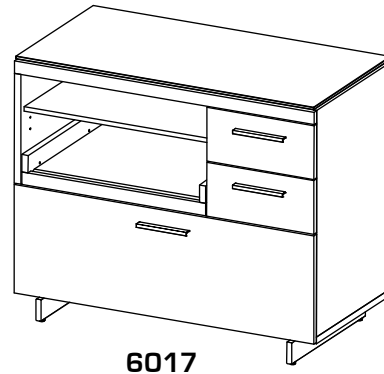

### Step 1 Unpack and Identify

Unpack and identify the components. The assembly workspace should be a non-marring surface such as carpet. For missing hardware pieces, please contact BDI Customer Service at [customerservice@bdiusa.com](mailto:customerservice@bdiusa.com). For all other concerns, please contact your BDI Retailer.

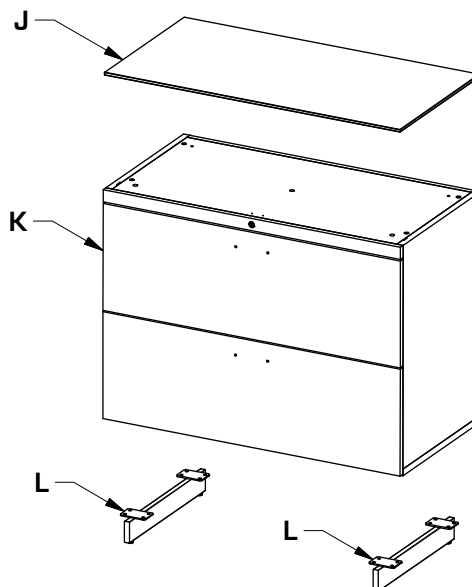

### Step 2

#### Attach Base Legs

Attach **Base Legs (L)** to bottom of **Cabinet (K)** with **Machine Screws (B)** Black Color Screws and tighten with **4mm Hex L-Wrench (A)**.  
Adjust Levelers as necessary.

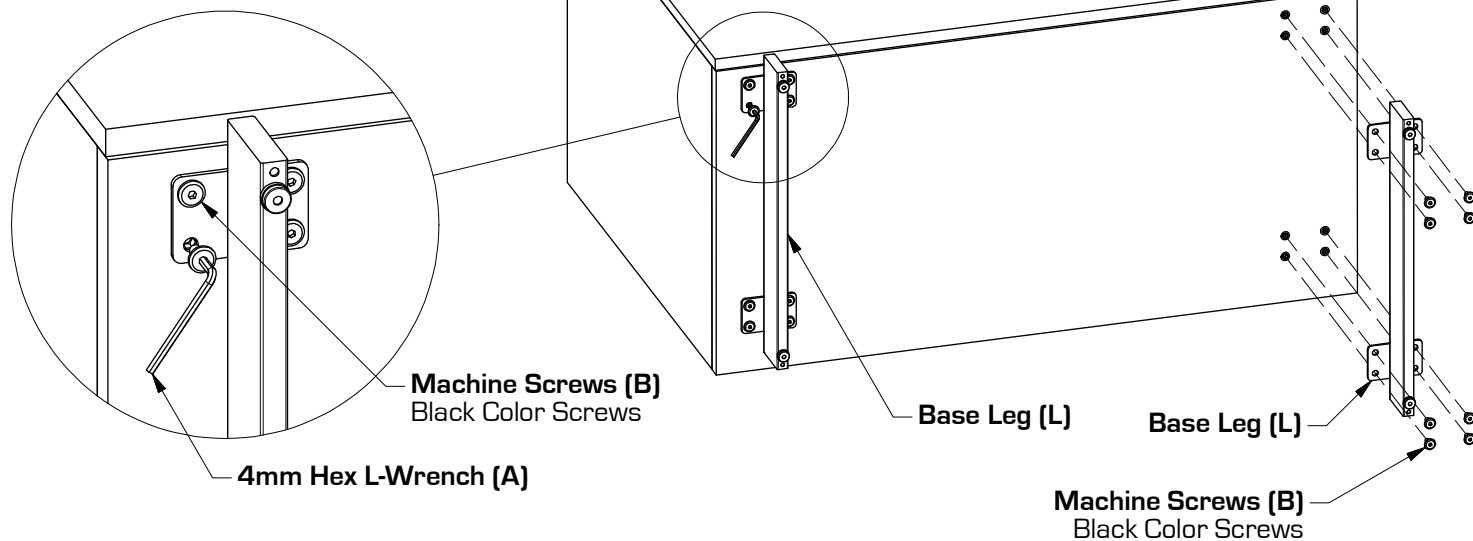

### Step 3

#### Attach Glass Top

Install **Rubber Stem Bumpers (D)** into holes in rear of top of **Cabinet (K)**.  
Open top drawer halfway to access screws to attach glass. Lower **Glass Top (J)** onto **Cabinet (K)** with 2 glass fittings towards the front. Attach **Glass Top (J)** with 3 **Machine Screws (C)** Chrome Color Screws and tighten with **4mm Hex L-Wrench (A)**.  
**DO NOT OVER-TIGHTEN.**

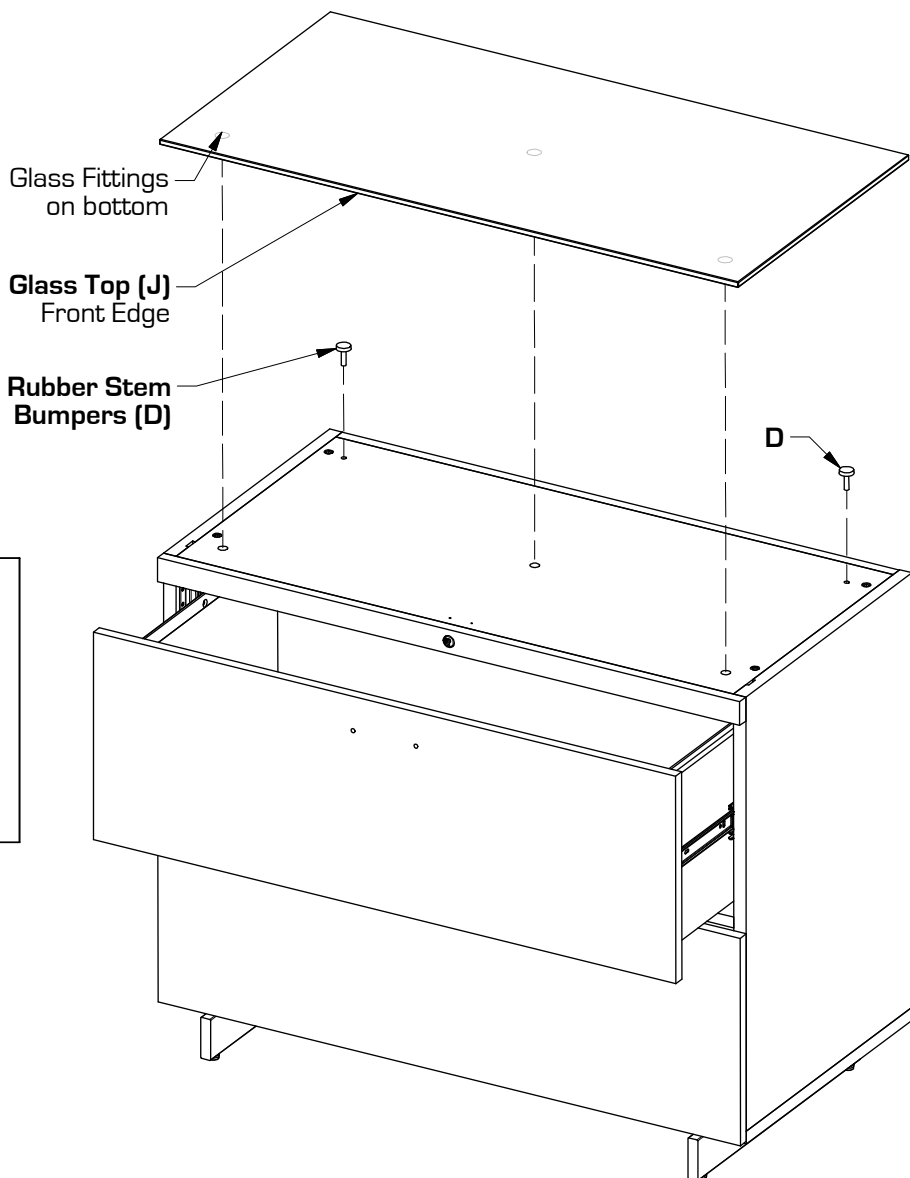
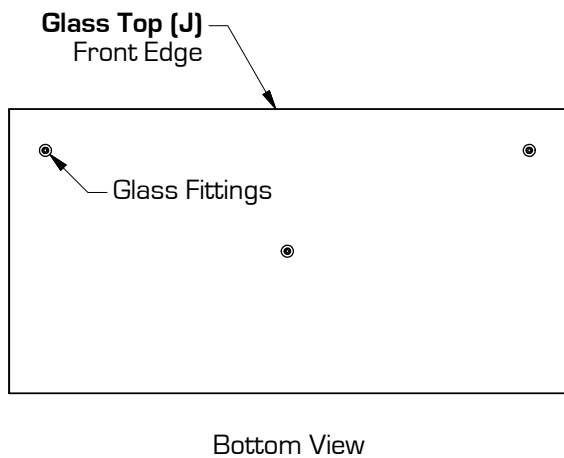

#### Step 4

##### Attach Handles (G) to Drawers with

**Machine Screws (F)** and tighten with Phillips Screwdriver.

Attach **Handles (G)** to Doors on 6015 with **Machine Screws (E)** and tighten with Phillips Screwdriver.

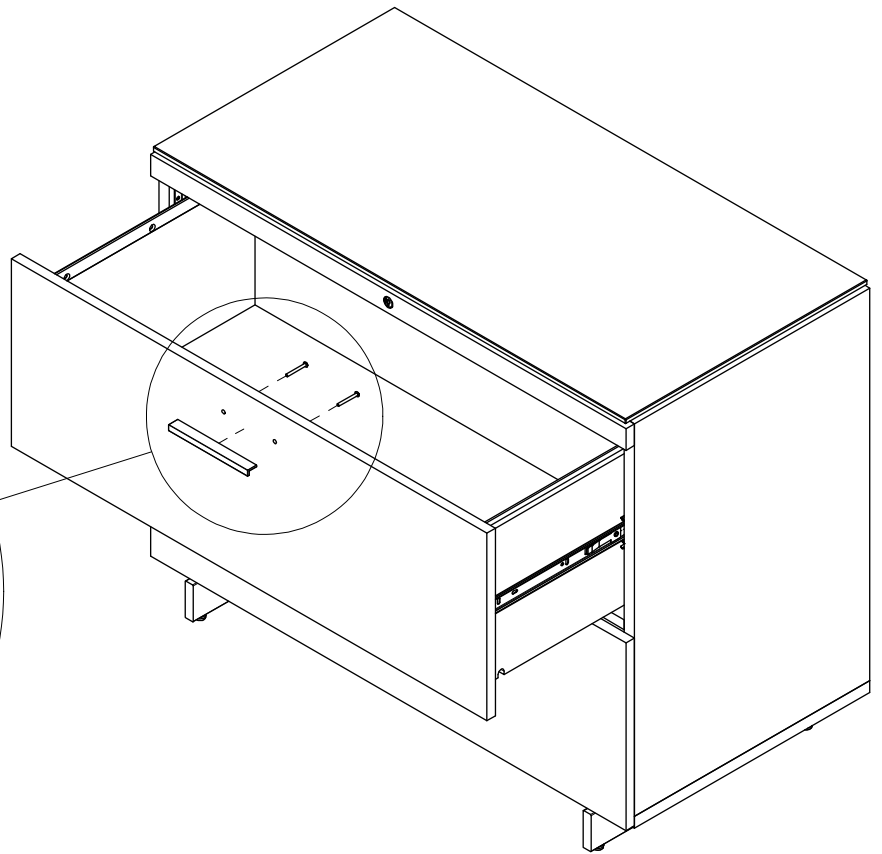
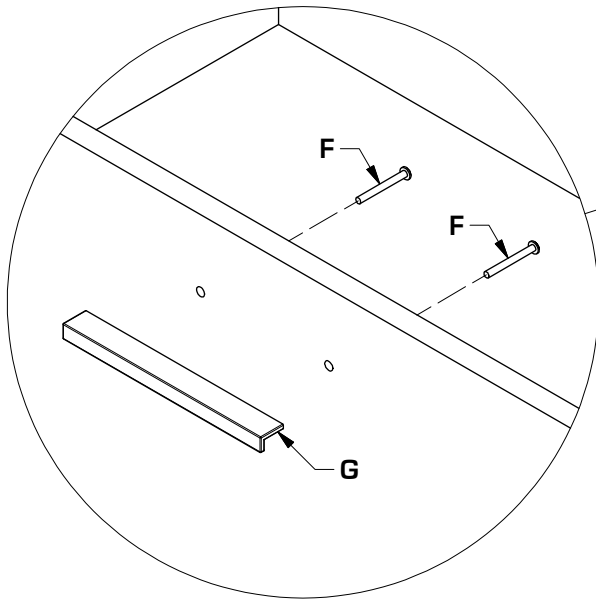

#### Step 5

##### Optional - Install File Folder Brackets

Legal File Folders can be installed in the lateral drawers front to back without installing File Folder Brackets. If users wish to install Letter or A4 File Folders Front to Back, install **Large File Folder Bracket (H)** by lowering bracket onto drawer sides [see Fig. 5.1].

If users wish to install File Folders side to side, install **Small File Folder Brackets (I)** by lower brackets onto drawer front and back [see Fig. 5.2]

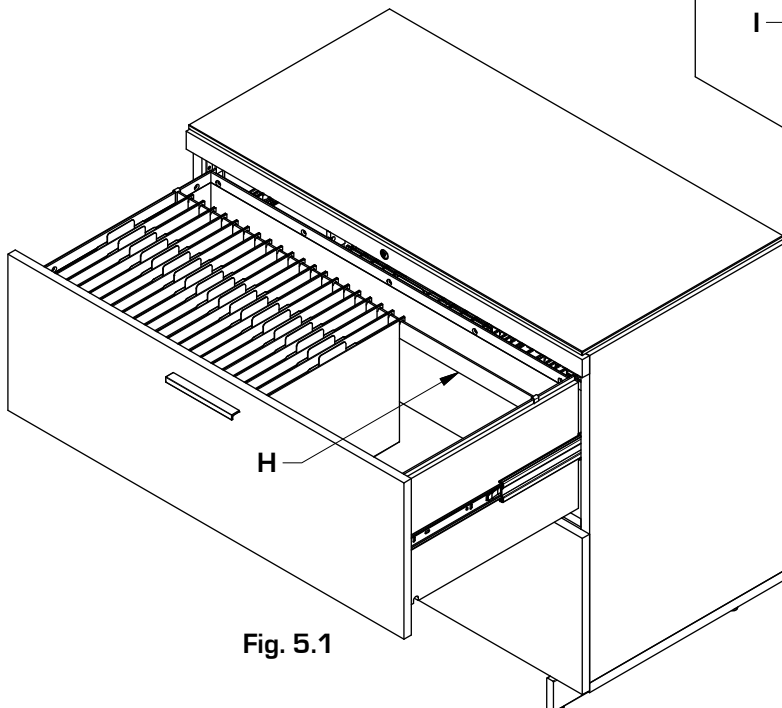

Fig. 5.1

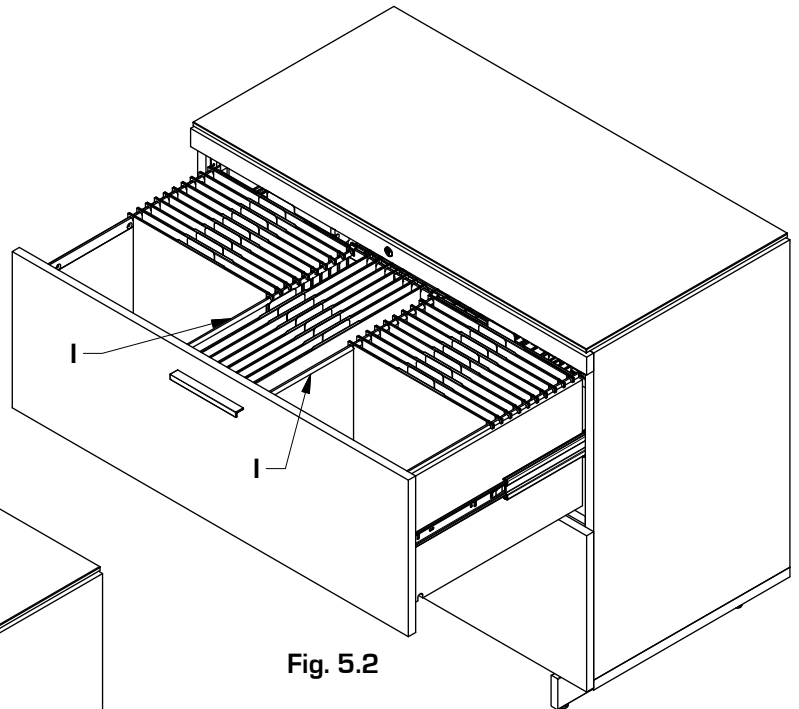
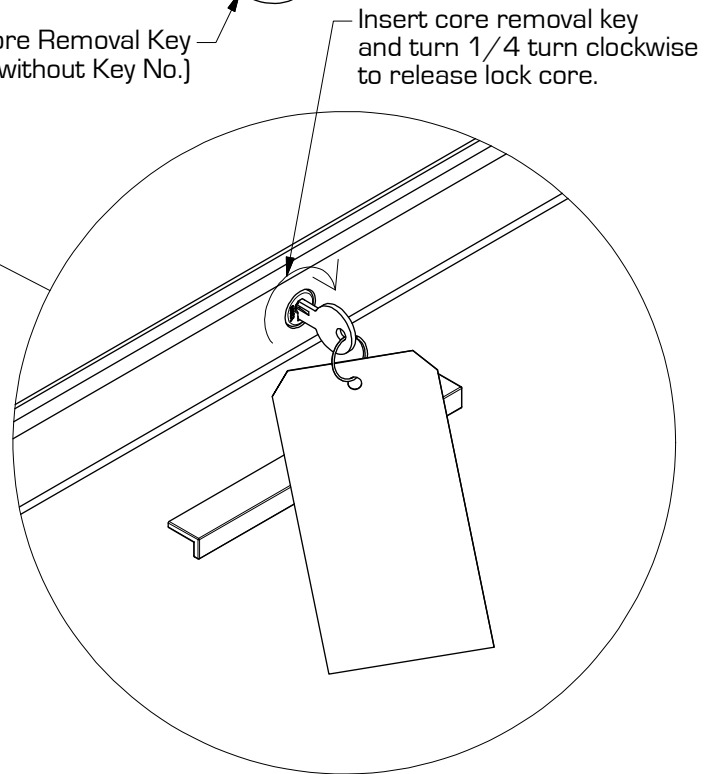
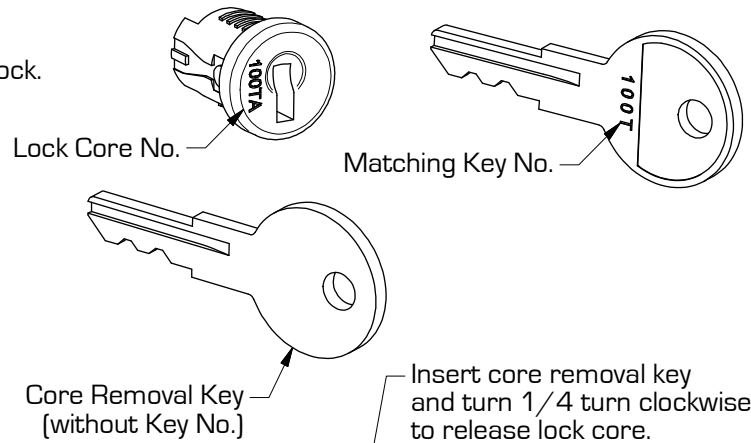
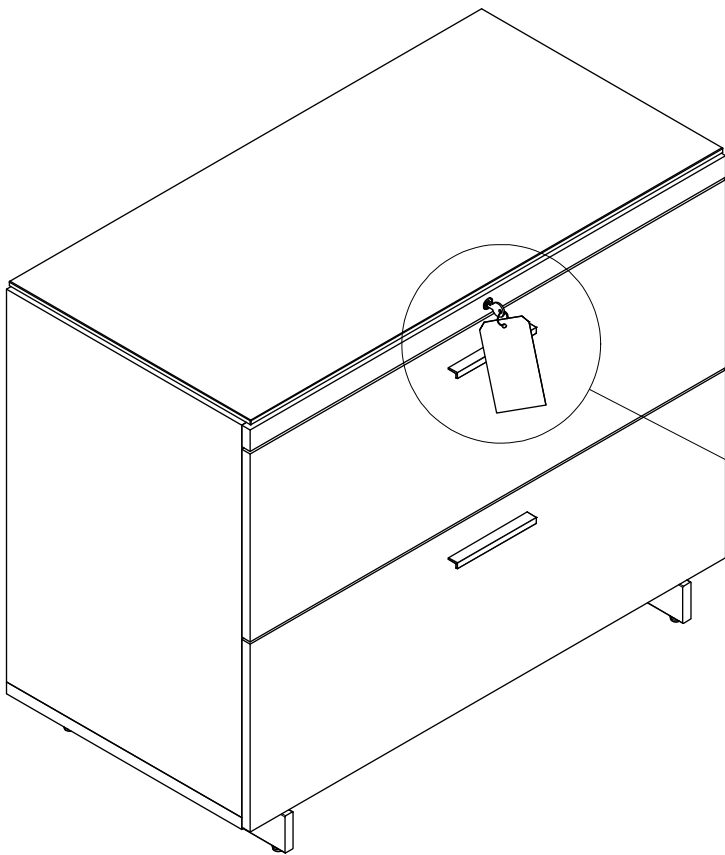

Fig. 5.2

All 6016 SEQUEL LATERAL FILE CABINETS are pre-assembled with matching locks. If you require unique locks for your home or office use, please contact BDI Customer Service at [customerservice@bdiusa.com](mailto:customerservice@bdiusa.com) to purchase a unique lock and key replacement kit which includes a numbered lock core, two keys and a core removal key. There is a number on the face of each lock core and a matching number on the key. To replace the lock please follow the instructions below.

### Optional - Lock Removal and Installation

1. Using normal key, turn lock fully clockwise.
2. Remove normal key and insert core removal key into the lock.
3. Rotate core removal key clockwise 1/4 turn.



4. Pull lock core straight out from cylinder body.
5. Insert new lock core into cylinder body until the lock core snaps into place.

