

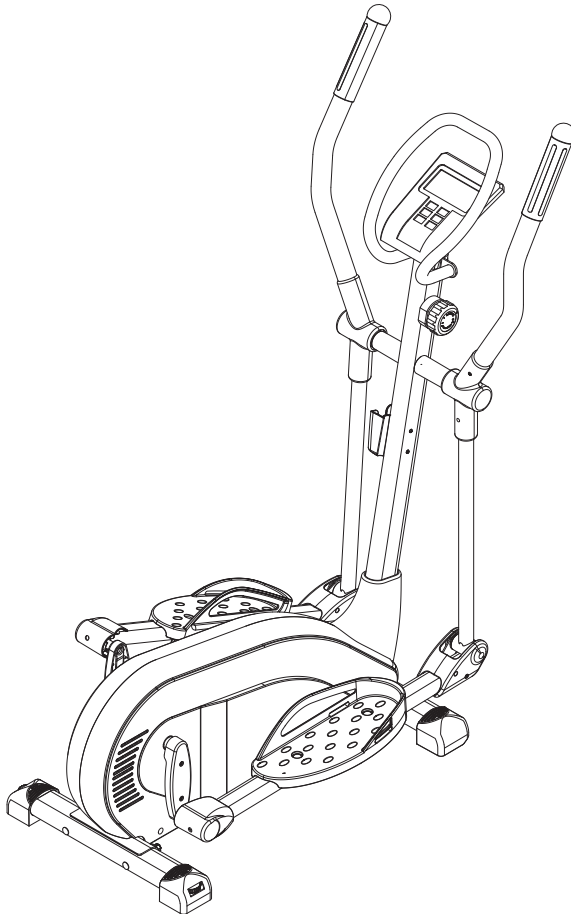

Elliptical Trainer *2000E*

Owner's Manual



Product May Vary Slightly From Pictured.

CAUTION:

Weight on this product should not exceed 250 lbs.

⚠ WARNING

Exercise can present a health risk. Consult a physician before beginning any exercise program with this equipment. If you feel faint or dizzy, immediately discontinue use of this equipment. Serious bodily injury can occur if this equipment is not assembled and used correctly. Serious bodily injury can also occur if all instructions are not followed. Keep others and pets away from equipment when in use. Always make sure all bolts and nuts are securely tightened prior to each use. Follow all safety instructions in this manual.

When calling for parts or service, please specify the following number:

Model#: A550-110A

This Product is Distributed Exclusively by



2040 N. Alliance, Springfield, MO 65803

Customer Service

1 (800) 375-7520

www.staminaproducts.com

**STAMINA PRODUCTS
MADE IN CHINA**

© 2012 Stamina Products, Inc.
2012, 12

TABLE OF CONTENTS

Safety Instructions	2	Maintenance	21
Before You Begin	4	Conditioning Guidelines	22
Equipment Warning, Caution & Notice Labels ...	5	Warm-Up and Cool-Down	23
Hardware Identification Chart	6	Product Parts Drawing	24
Assembly Instructions	7	Parts List	25
Set Up Instructions	13	Warranty	27
Operational Instructions	14	Notes	28
Storage	21	Fax/Mail Ordering Form	30

SAFETY INSTRUCTIONS

⚠ WARNING This product contains a chemical known to the State of California to cause cancer and birth defects or other reproductive harm.

⚠ WARNING Consult your physician before starting this or any exercise program. This is especially important if you are over the age of 35, have never exercised before, are pregnant, or suffer from any health problem. This product is for home use only. Do not use in institutional or commercial applications. Failure to follow all warnings and instructions could result in serious injury or death.

⚠ WARNING To reduce the risk of serious injury, read the following Safety Instructions before using the AVARI® 2000E Elliptical Trainer.

1. Read all warnings and cautions posted on the AVARI® 2000E Elliptical Trainer.
2. The AVARI® 2000E Elliptical Trainer should only be used after a thorough review of the Owner's Manual. Make sure that it is properly assembled and tightened before use.
3. We recommend that two people be available for assembly of this product.
4. Keep children away from the AVARI® 2000E Elliptical Trainer. Do not allow children to use or play on the AVARI® 2000E Elliptical Trainer. Keep children and pets away from the AVARI® 2000E Elliptical Trainer when it is in use.
5. It is recommended that you place this exercise equipment on an equipment mat.
6. Set up and operate the AVARI® 2000E Elliptical Trainer on a solid level surface. Do not position the AVARI® 2000E Elliptical Trainer on loose rugs or uneven surfaces.
7. Make sure that adequate space is available for access to and around the AVARI® 2000E Elliptical Trainer.
8. Adjust the Adjustable Endcaps(81) on the Rear Stabilizer(2) so that the AVARI® 2000E Elliptical Trainer sits on the floor without rocking.
9. Before using, inspect the AVARI® 2000E Elliptical Trainer for worn or loose components, and securely tighten or replace any worn or loose components prior to use.
10. Consult a physician prior to commencing an exercise program and follow his/her recommendations in developing your fitness program. If at any time during exercise you feel faint, dizzy, or experience pain, stop and consult your physician.
11. Always choose the workout which best fits your physical strength and flexibility level. Know your limits and train within them. Always use common sense when exercising.
12. Do not wear loose or dangling clothing while using the AVARI® 2000E Elliptical Trainer.
13. Never exercise in bare feet or socks; always wear proper footwear such as running, walking, or cross training shoes that fit well, provide foot support, and feature non-skid rubber soles.
14. Be careful to maintain your balance while using, mounting, dismounting, or assembling the AVARI® 2000E Elliptical Trainer, loss of balance may result in a fall and serious bodily injury. Before mounting or dismounting, move the pedal on the mounting or dismounting side to its lowest position and bring the machine to a complete stop.
15. The AVARI® 2000E Elliptical Trainer is not equipped with a free-wheel. Pedal speed should be reduced in a controlled manner.
16. The AVARI® 2000E Elliptical Trainer should not be used by persons weighing over 250 pounds.
17. The AVARI® 2000E Elliptical Trainer should be used by only one person at a time.
18. The AVARI® 2000E Elliptical Trainer is for consumer use only. It is not for use in public or semipublic facilities.

Call Us First



Customer Service
1 (800) 375-7520
www.staminaproducts.com

THANK YOU FOR PURCHASING THE AVARI® 2000E Elliptical Trainer

To enact your warranty, please register your product
by going to register.staminaproducts.com

To help you get started, we have pre-assembled most of your
AVARI® 2000E Elliptical Trainer at the factory with the exception
of those few parts left unassembled for shipping purposes.
Simply follow the few assembly instructions set forth in this manual.
With regular workouts, you will be getting your body into shape
and be on your way to achieving a happier and healthier lifestyle.

Should you have any questions,
please call our Customer Service Department toll-free number,
1 (800) 375-7520
Monday - Thursday, 7:30 A.M. - 5:00 P.M., Central Time.
Friday, 8:00 A.M. - 3:00 P.M., Central Time.



ONLINE
CUSTOMER SERVICE
customerservice@staminaproducts.com
www.staminaproducts.com



TELEPHONE
CUSTOMER SERVICE
Tel: 1 (800) 375-7520



FAX
CUSTOMER SERVICE
Fax: (417) 889-8064



MAIL
STAMINA PRODUCTS, INC.
ATTN: Customer Service
P.O. Box 1071
Springfield, MO. 65801-1071



BEFORE YOU BEGIN

Thank you for choosing the **AVARI® 2000E Elliptical Trainer**. We take great pride in producing this quality product and hope it will provide many hours of quality exercise to make you feel better, look better, and enjoy life to its fullest.

It's a proven fact that a regular exercise program can improve your physical and mental health. Too often, our busy lifestyles limit our time and opportunity to exercise. The **AVARI® 2000E Elliptical Trainer** provides a convenient and simple method to begin your assault on getting your body in shape and achieving a happier and healthier lifestyle.

Before reading further, please review the drawing below and familiarize yourself with the parts that are labeled.

Read this manual carefully before using the **AVARI® 2000E Elliptical Trainer**.

Although Stamina constructs its products with the finest materials and uses the highest standards of manufacturing and quality control, there can sometimes be missing parts or incorrectly sized parts. If you have any questions or problems with the parts included with your **AVARI® 2000E Elliptical Trainer**, please do not return the product. Contact us **FIRST!**

If a part is missing or defective, please go to staminaproducts.com to the Services section and order the part needed, or call us toll free at 1-800-375-7520 (in the U.S.). Our Customer Service Staff is available to assist you from 7:30 A.M. to 5:00 P.M. (Central Time) Monday through Thursday and 8:00 A.M. to 3:00 P.M. (Central Time) on Friday.

Be sure to have the name and model number of the product available when you contact us.

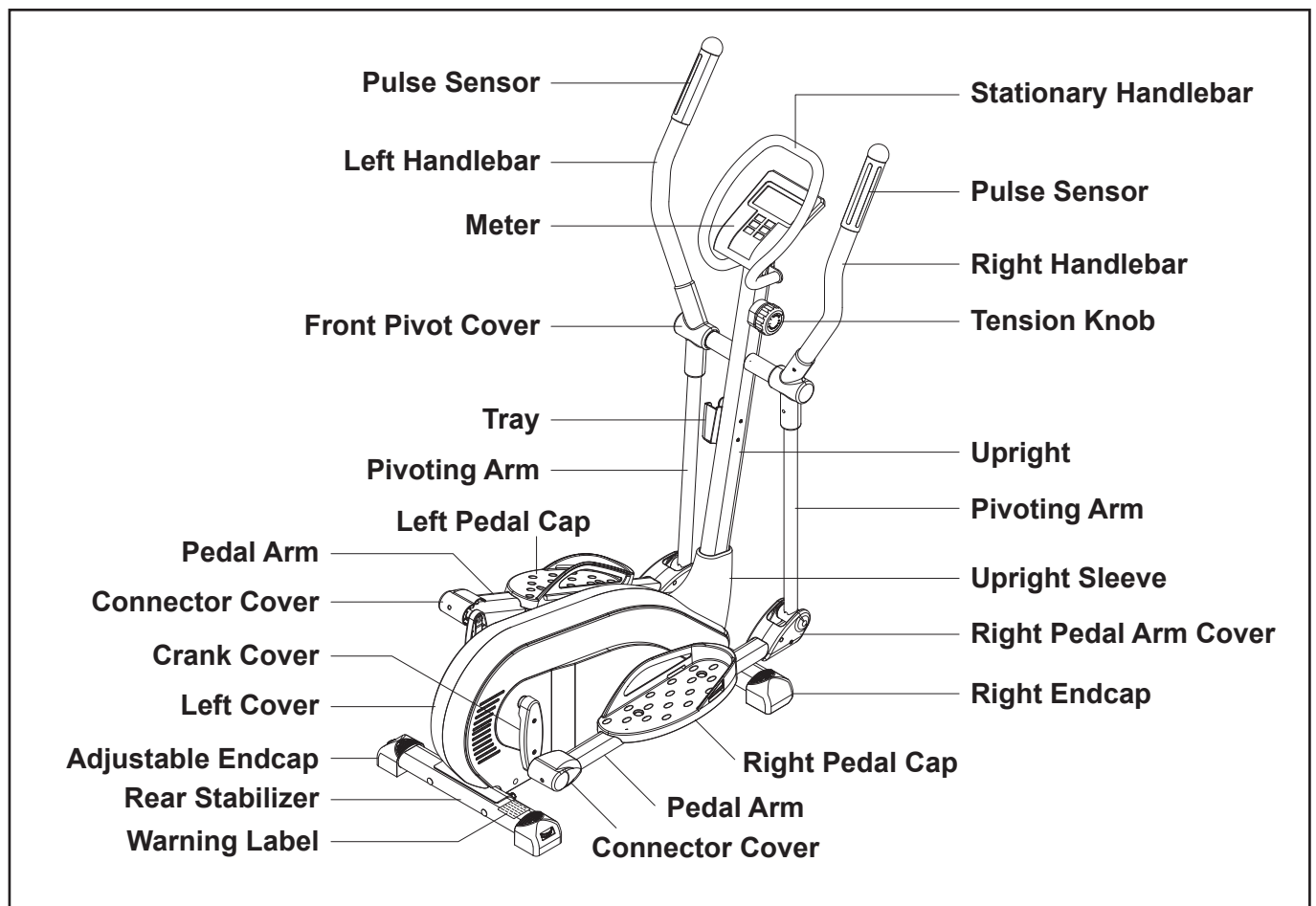

THE FOLLOWING TOOLS ARE INCLUDED FOR ASSEMBLY :



EQUIPMENT WARNING, CAUTION & NOTICE LABELS

This chart is provided to help identify the warning, caution, and notice labels on the **AVARI® 2000E Elliptical Trainer**. Please take a moment to familiarize yourself with all of the warning, caution, and notice labels.

Label is larger than actual size

W1 WARNING LABEL(95)







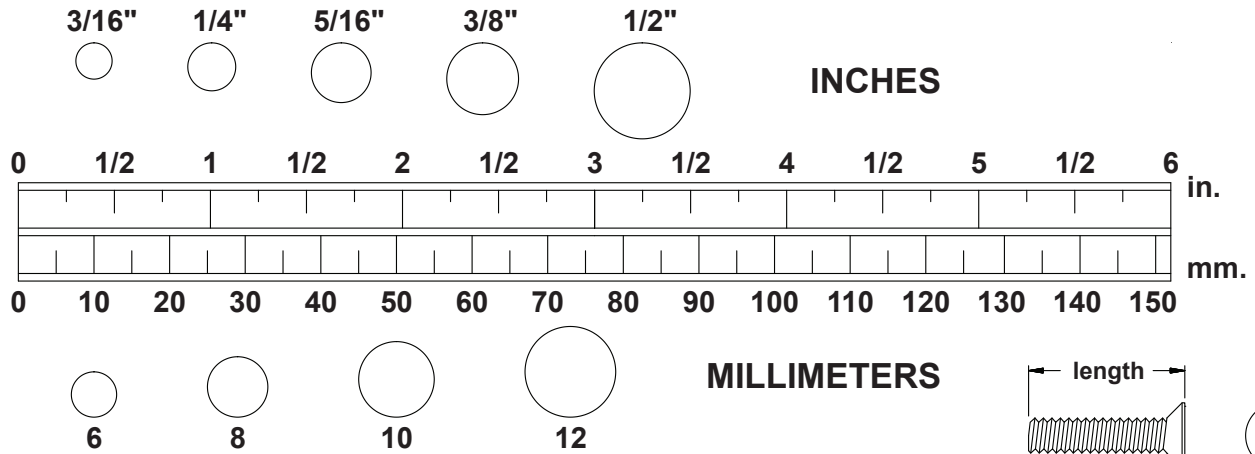





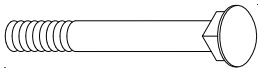
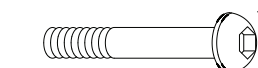
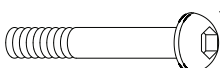

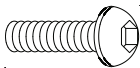

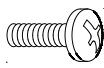

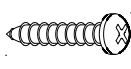

HARDWARE IDENTIFICATION CHART

This chart is provided to help identify the hardware used in the assembly process. Place the washers or the ends of the bolts or screws on the circles to check for the correct diameter. Use the small scale to check the length of the bolts and screws.



NOTICE: The length of all bolts and screws, except those with flat heads, is measured from below the head to the end of the bolt or screw. Flat head bolts and screws are measured from the top of the head to the end of the bolt or screw.

After unpacking the unit, open the hardware bag and make sure that you have all the following items. Some hardware may be already attached to the part.

	Part No. and Description	Qty
	44 Carriage Bolt (M10 x 1.5 x 94mm)	4
	45 Carriage Bolt (M10 x 1.5 x 50mm)	4
	48 Bolt, Button Head (M8 x 1.25 x 88mm)	2
	49 Bolt, Button Head (M10 x 1.5 x 76mm)	2
	50 Bolt, Button Head (M8 x 1.25 x 36mm)	4
	52 Bolt, Button Head (M8 x 1.25 x 20mm)	4
	53 Bolt, Button Head (M8 x 1.25 x 25mm)	2
	56 Screw, Small Round Head (M5 x 0.8 x 10mm)	2
	74 Screw, Round Head (M5 x 0.8 x 25mm)	1
	94 Screw, Round Head (M5 x 0.8 x 10mm)	4
	57 Screw, Small Round Head (M4 x 35mm)	4
	58 Screw, Small Round Head (M4 x 20mm)	6
	59 Screw, Round Head (M4 x 30mm)	2
	61 Arc Washer (M10)	4
	62 Arc Washer (M8)	2
	63 Washer (M10)	6
	65 Washer (M8)	6
	75 Washer (M5)	1
	67 Lock Washer (M10)	4
	68 Lock Washer (M8)	8
	69 Nylock Nut (M10 x 1.5)	6
	70 Nylock Nut (M8 x 1.25 x 8mm thick)	2
	71 Thin Nylock Nut (M8 x 1.25 x 6.35mm thick)	4

ASSEMBLY INSTRUCTIONS

Place all parts from the box in a cleared area and position them on the floor in front of you. Remove all packing materials from your area and place them back into the box. Do not dispose of the packing materials until assembly is completed. Read each step carefully before beginning. If you are missing a part, please go to staminaproducts.com to the Services section and order the part needed, e-mail us at customerservice@staminaproducts.com, or call us toll free at 1-800-375-7520 (in the U.S.). Our Customer Service Staff is available to assist you from 7:30 A.M. to 5:00 P.M. (Central Time) Monday through Thursday and 8:00 A.M. to 3:00 P.M. (Central Time) on Friday.

STEP 1

Refer to detail view **A**. Attach the **FRONT STABILIZER(3)**, the shorter stabilizer with the non-adjustable **ENDCAPS(100, 101)**, to the front of the **MAIN FRAME(1)** with **CARRIAGE BOLTS(M10x1.5x94mm)(44)**, **ARC WASHERS(M10)(61)**, **LOCK WASHERS(M10)(67)**, and **NYLOCK NUTS(M10x1.5)(69)**.

STEP 2

Attach the **REAR STABILIZER(2)** to the **MAIN FRAME(1)** with **CARRIAGE BOLTS(M10x1.5x94mm)(44)**, **ARC WASHERS(M10)(61)**, **LOCK WASHERS(M10)(67)**, and **NYLOCK NUTS(M10x1.5)(69)**.

NOTE: You can turn the dials in the **ADJUSTABLE ENDCAPS(81)** which are attached to the **REAR STABILIZER(2)** to keep the **AVARI® 2000E Elliptical Trainer** stable.

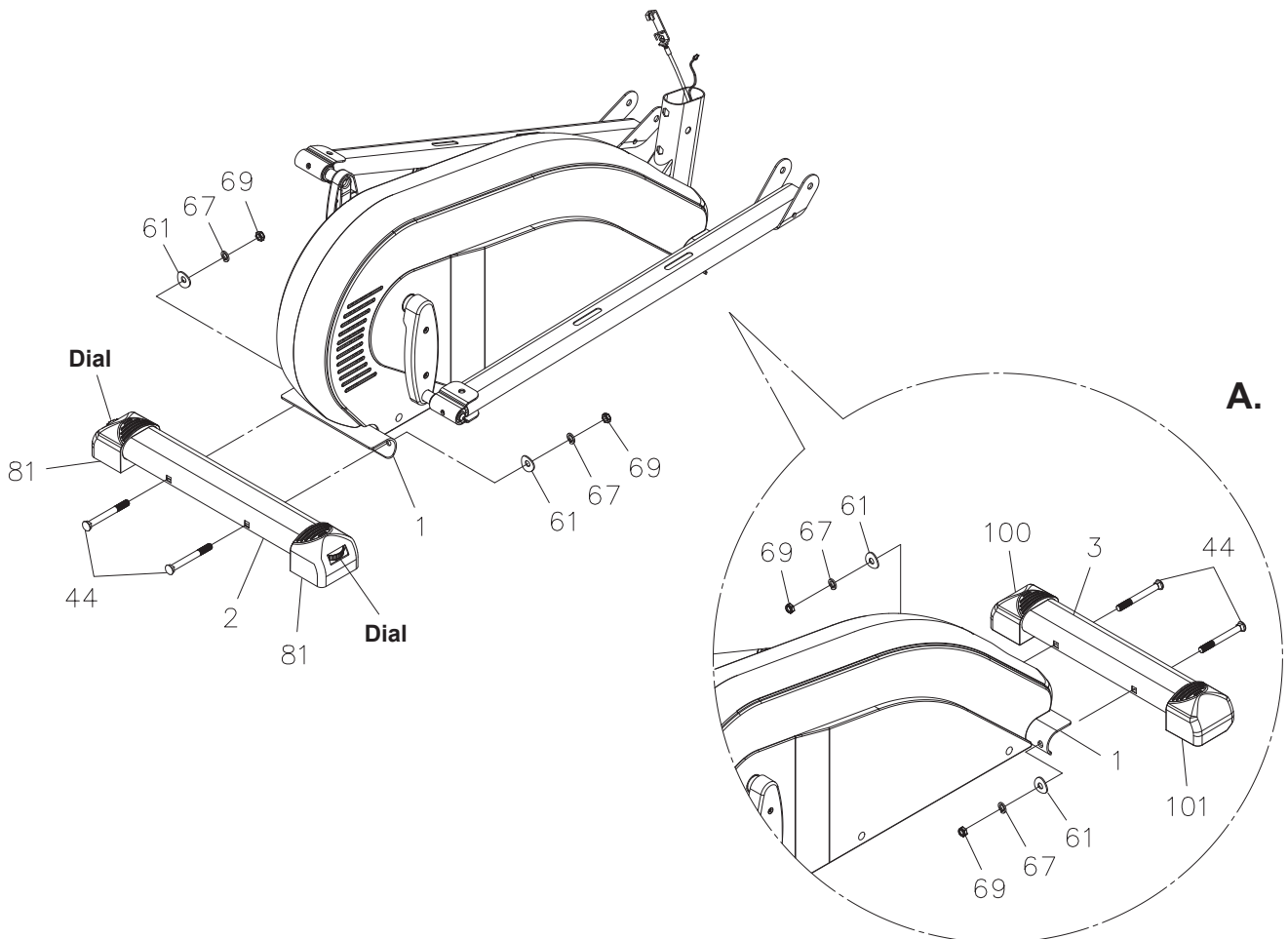

ASSEMBLY INSTRUCTIONS

STEP 3: Slide the **UPRIGHT SLEEVE(88)** over the **UPRIGHT(4)**. Insert the **TENSION CABLE(27)** through the **UPRIGHT(4)** until the **TENSION CABLE(27)** is through and extends out of the square opening in the side of the **UPRIGHT(4)**. Connect the **CONNECTION WIRE(28)** to the **SENSOR WIRE(26)**. Insert the **UPRIGHT(4)** into the **MAIN FRAME(1)** and secure with **BUTTON HEAD BOLTS(M8x1.25x88mm)(48)**, **BUTTON HEAD BOLTS(M8x1.25x20mm)(52)**, **LOCK WASHERS(M8)(68)**, **WASHERS(M8)(65)**, **ARC WASHERS(M8)(62)**, and **NYLOCK NUTS(M8x1.25)(70)**. Slide down the **UPRIGHT SLEEVE(88)** to cover the bolt heads.

STEP 4: Attach the **TRAY(87)** to the **UPRIGHT(4)** with **ROUND HEAD SCREWS(M4x30mm)(59)**.

STEP 5: Refer to the inset drawing and the illustration below. To connect the **TENSION KNOB(22)** to the **TENSION CABLE(27)**:

1. Set the **TENSION KNOB(22)** at position "8", so the **CABLE END** extends out of the **METAL FITTING** as far as possible. Connect the **CABLE END** of the **TENSION KNOB(22)** to the **HOOK** on the end of the **TENSION CABLE(27)**.
2. Pull on the Cable of the **TENSION KNOB(22)** firmly so that enough cable is available to allow the **METAL FITTING** go through the slot in the top of the **BRACKET**.
3. Insert the **METAL FITTING** into the hole at the end of the slot in the **BRACKET**.
4. Adjust the **TENSION KNOB(22)** and verify that the **HOOK** moves when the **TENSION KNOB(22)** is adjusted.
5. Attach the **TENSION KNOB(22)** to the **UPRIGHT(4)** with **ROUND HEAD SCREW(M5x0.8x25mm)(74)** and **WASHER(M5)(75)**.

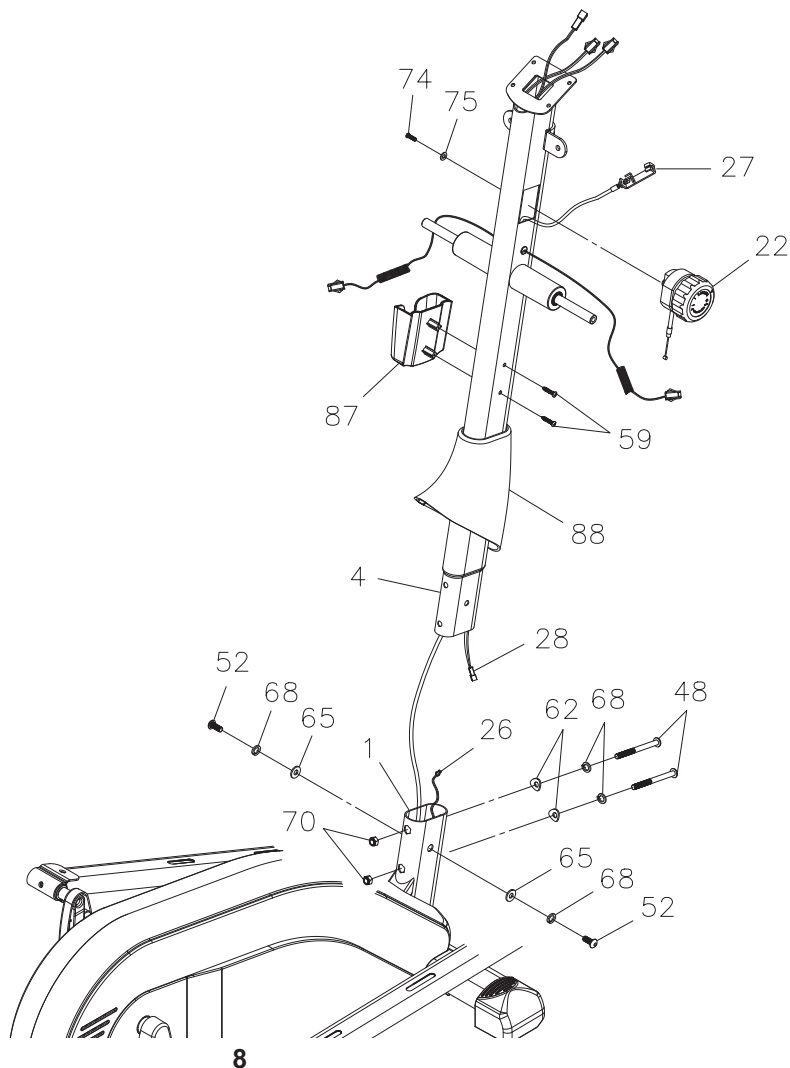
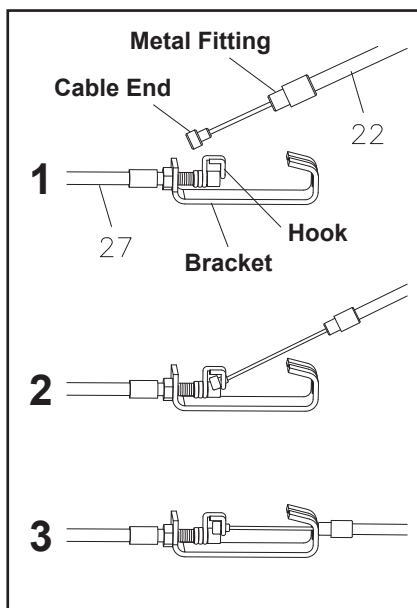

ASSEMBLY INSTRUCTIONS

STEP 6

Slide the **PIVOTING ARMS(6)** onto the **SHAFT** on the **UPRIGHT(4)** on both sides and secure with **WASHERS(M8)(65)**, **LOCK WASHERS(M8)(68)**, and **BUTTON HEAD BOLTS(M8x1.25x20mm)(52)**.

STEP 7

There is a tie on the lower end of the **PIVOTING ARM(6)** at right side to keep the parts in place during shipping. Use scissors to cut the tie. Slide the lower end of the **PIVOTING ARM(6)** into the bracket on the **PEDAL ARM(5)** which at right side, and secure with **BUTTON HEAD BOLT(M10x1.5x76mm)(49)**, **WASHER(M10)(63)**, and **NYLOCK NUT(M10x1.5)(69)**. Repeat to attach the opposite side.

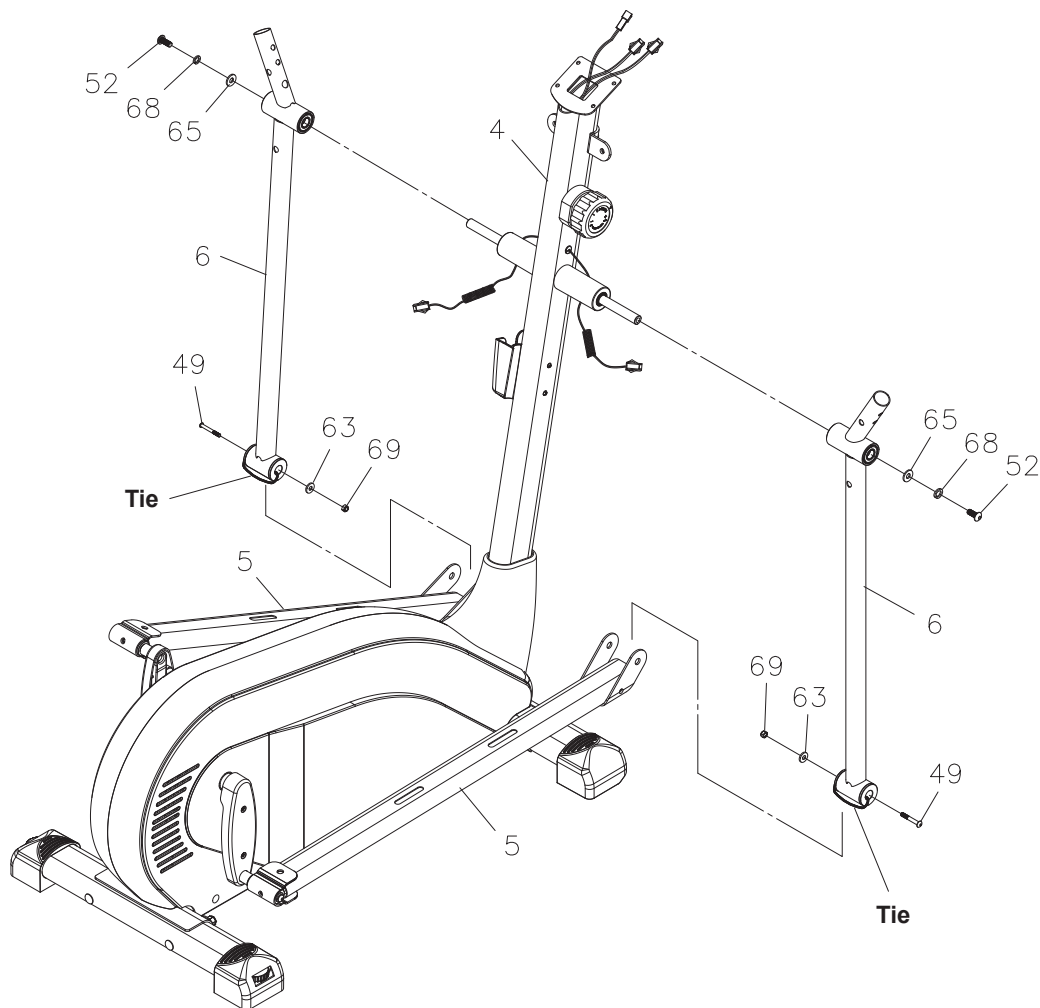

ASSEMBLY INSTRUCTIONS

STEP 8

There is a “R” decal on the **RIGHT HANDLEBAR(9)**, and a “L” decal on the **LEFT HANDLEBAR(10)**. Refer to detail view **B**. Feed the plug end of the **PULSE SENSOR WIRE(30)** through the tube on the top of the **PIVOTING ARM(6)**. Insert the **LEFT HANDLEBAR(10)** into the **PIVOTING ARM(6)** and secure with **BUTTON HEAD BOLTS(M8x1.25x36mm)(50)** and **THIN NYLOCK NUTS(M8x1.25)(71)**. Connect the **PULSE SENSOR WIRE(30)** to the **PULSE CONNECTION WIRE(29)** and push the plugs into the **PIVOTING ARM(6)**. Clip a **GROMMET PLUG(32)** onto the **PULSE CONNECTION WIRE(29)** and press the **GROMMET PLUG(32)** into the hole in the **PIVOTING ARM(6)**. Repeat on the right side.

STEP 9

Attach the **STATIONARY HANDLEBAR(11)** to the **UPRIGHT(4)** with **BUTTON HEAD BOLTS(M8x1.25x25mm)(53)**, **LOCK WASHERS(M8)(68)**, and **WASHERS(M8)(65)**.

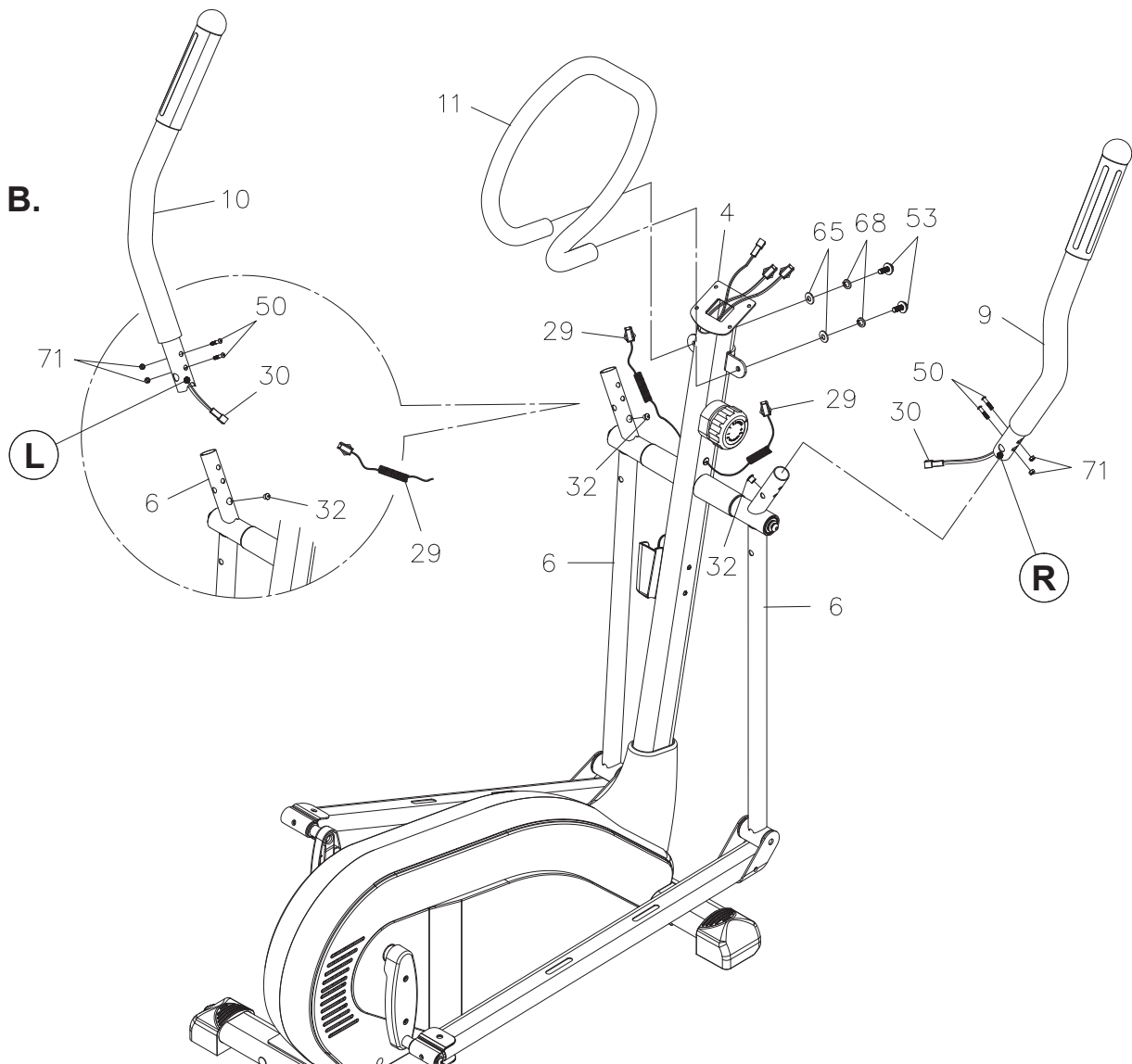

ASSEMBLY INSTRUCTIONS

STEP 10

There is a "R" decal on the **RIGHT PEDAL CAP(78)**, and a "L" decal on the **LEFT PEDAL CAP(79)**. Attach the **RIGHT PEDAL CAP(78)** to the **PEDAL ARM(5)** on the right side with the **LOCKING KNOBS(77)**, **WASHERS(M10)(63)**, and **CARRIAGE BOLTS(M10x1.5x50mm)(45)**. Repeat on the left side.

NOTE: You can loosen the **LOCKING KNOBS(77)** to adjust the **PEDAL CAPS(78, 79)** to the front or back. Securely tighten the **LOCKING KNOBS(77)** after adjustment. Always set the **PEDAL CAPS(78, 79)** at the same position on both sides.

STEP 11

Install two AAA batteries into the **METER(25)**, the batteries are not included. See page 21 for detailed battery installation instructions. Plug the **CONNECTION WIRE(28)** and **PULSE CONNECTION WIRES(29)** into the **METER(25)**, and push the excess wires back into the **UPRIGHT(4)**. Attach the **METER(25)** to the plate on the **UPRIGHT(4)** with **ROUND HEAD SCREWS(M5x0.8x10mm)(94)**.

NOTE: Be careful not to damage the wires when attaching the **METER(25)** to the **UPRIGHT(4)**.

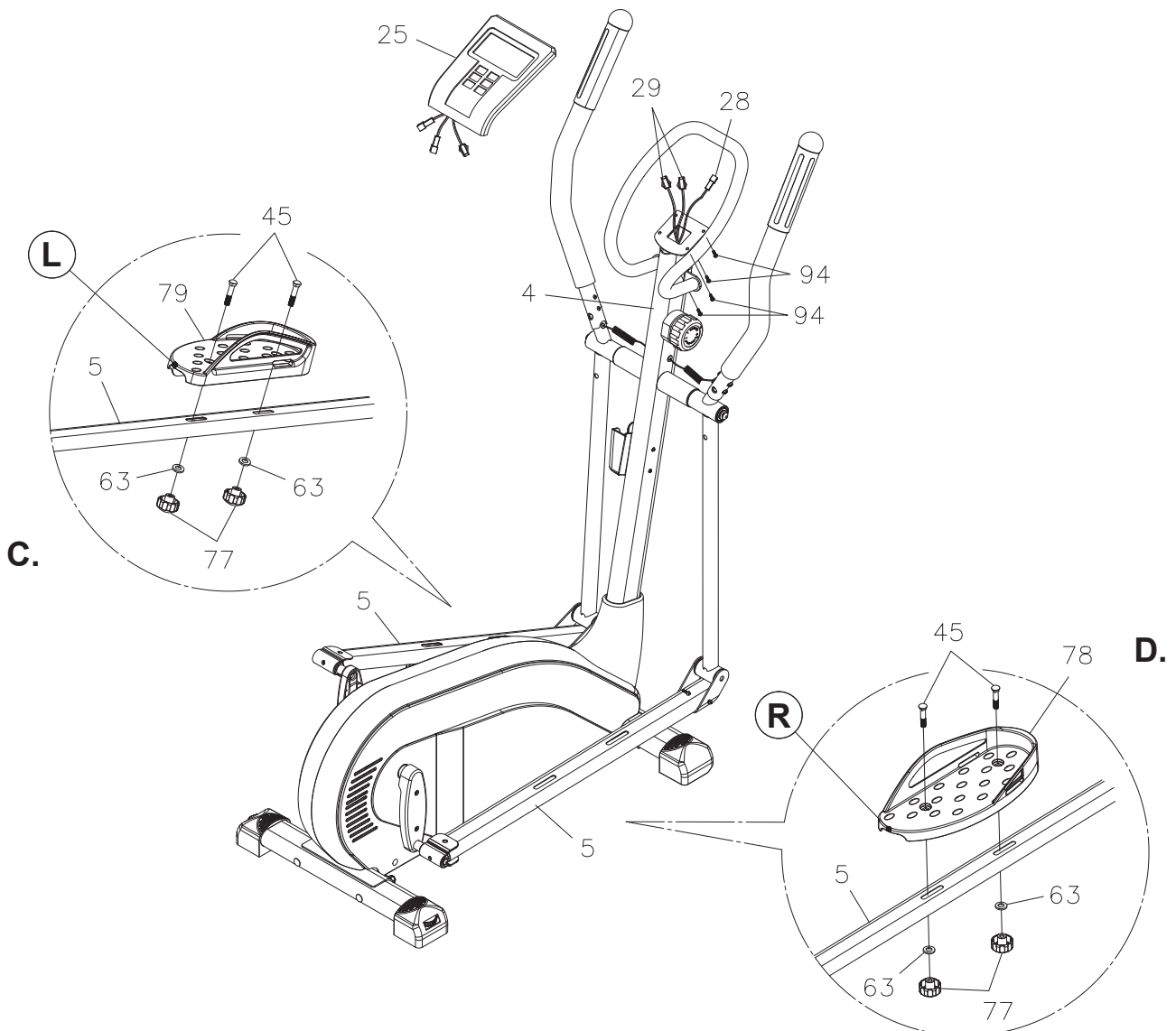

ASSEMBLY INSTRUCTIONS

STEP 12

Attach the **FRONT** and **BACK PIVOT COVER(7, 8)** to the **LEFT HANDLEBAR(10)** and **PIVOTING ARM(6)** with **SMALL ROUND HEAD SCREWS(M4x35mm)(57)**. Repeat on the right side.

STEP 13

Refer to detail views **E** and **F**. Attach the **RIGHT** and **LEFT PEDAL ARM COVERS(91, 92)** to the **PEDAL ARMS(5)** on both sides with **SMALL ROUND HEAD SCREWS(M4x20mm)(58)**.

STEP 14

Attach the **CONNECTOR COVERS(89)** to the **PEDAL ARM CONNECTORS(14)** on both sides with **SMALL ROUND HEAD SCREWS(M5x0.8x10mm)(56)**.

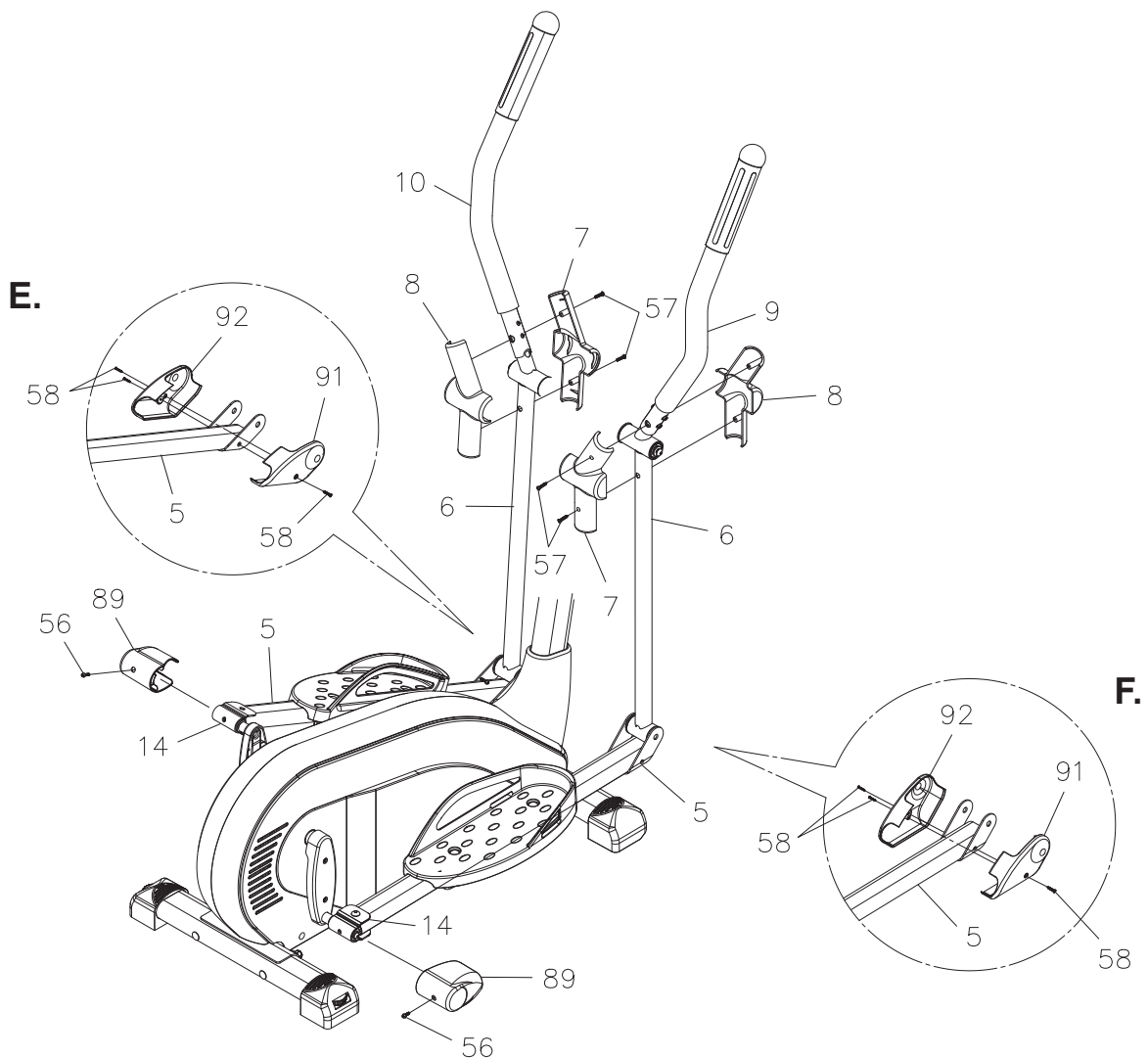

SET UP INSTRUCTIONS

Place the **AVARI® 2000E Elliptical Trainer** in the area where it will be used. It is recommended that the **AVARI® 2000E Elliptical Trainer** be placed on an equipment mat. The maximum operation dimensions of the **AVARI® 2000E Elliptical Trainer** are approximately 52.6 inches long x 25.4 inches wide x 57 inches tall. (These dimensions may vary up to one inch.) Make sure that adequate space is available for access to passage around and emergency dismount from the **AVARI® 2000E Elliptical Trainer**. A minimum of 20 inches on at least one side and 20 inches either behind or in front of the **AVARI® 2000E Elliptical Trainer** is required for safe operation.

LEVELING: Turn the dials in the **ADJUSTABLE ENDCAPS(81)** which are attached to the **REAR STABILIZER(2)** so that the **AVARI® 2000E Elliptical Trainer** sits on the floor without rocking.

MOVING: The **AVARI® 2000E Elliptical Trainer** has a pair of wheels built into the **LEFT and RIGHT ENDCAPS(100, 101)** at the front. Grasp the **STATIONARY HANDLEBAR(11)** and tip the **AVARI® 2000E Elliptical Trainer** forward to move.

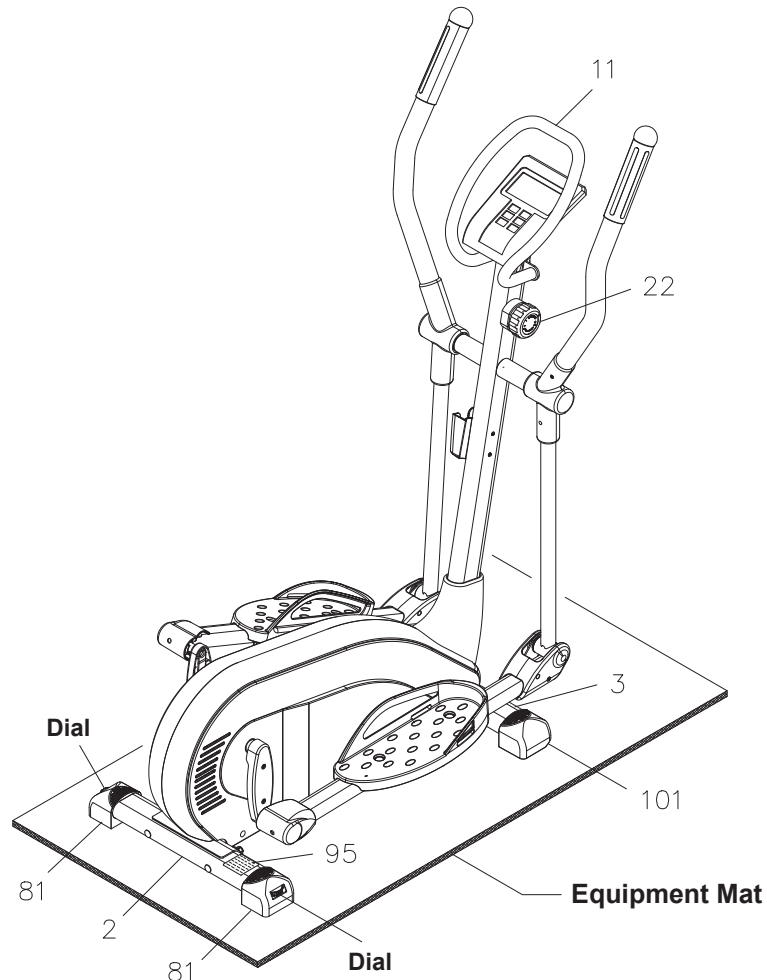

FUNCTION INSPECTION:

Visually inspect the **AVARI® 2000E Elliptical Trainer** to verify that assembly is as shown in the above illustration. Check the function of the **AVARI® 2000E Elliptical Trainer**, stand on the foot pedals and place your hands at a comfortable position on the handlebars. Slowly move your highest foot forward and follow the natural path of the machine. Turn the crank slowly through one complete revolution to verify that the drive train functions properly. Adjust the **TENSION KNOB(22)** and verify that it functions properly.

CAUTION: Locate and read the **WARNING LABEL(95)** on the **AVARI® 2000E Elliptical Trainer**. Make sure that all users read the **WARNING LABEL(95)** before using the product.

USAGE GUIDE

AVARI 2000E ELLIPTICAL TRAINER

Getting the most out of your Avari® Elliptical Trainer Workout

Elliptical trainers offer the benefit of a low-impact workout, while exercising both your upper and lower body. The elliptical is a cross between a treadmill and a cross country ski machine, but instead of your feet sliding back and forth like they would on skis, the shape of the elliptical movement mimics the natural path of the ankle, knee, and hip joints during walking, jogging or running. Since your feet never leave the pedals, your feet don't strike the ground so there is less stress and strain on your joints. It is like walking or running in midair. In comparison, when you walk or run, every step causes a jolt to your body that affects not only the joints in your legs, but also your lower back.

Before exercising, consult a physician.
Warm up properly before starting any routine.
Cool down completely before ending a workout.

WORKS THESE MUSCLE GROUPS

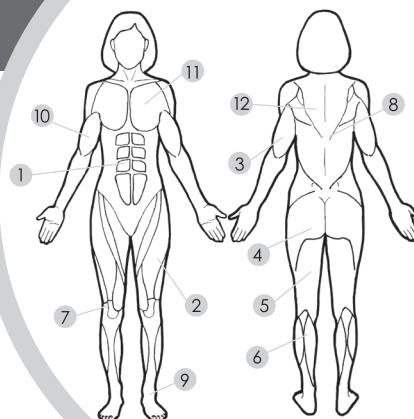

1. Abdominals
2. Quadriceps
3. Triceps
4. Gluteals
5. Hamstring
6. Calf
7. Knee
8. Erector Spinae
9. Ankles
10. Biceps
11. Chest
12. Back

Before you start your elliptical trainer workout

FAMILIARIZE YOURSELF WITH THE INTOUCH® FITNESS MONITOR.

This monitor has extra features that will help you track your progress to keep you motivated. Complete monitor instructions are on pages 16-21.



ADJUST THE PEDALS

Adjust the pedals by loosening the two locking knobs under each pedal, sliding the pedal forward or back, and then re-tightening the knobs. In proper position, you should be standing up tall with feet on the pedals, grasping the handlebars. The pedals can be positioned forward (closer) to the moving handlebars for those with a shorter reach, or back (further away from) the handlebars for those with a longer reach.

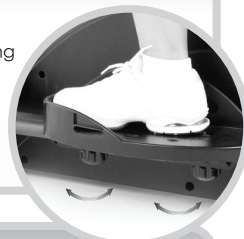

STAND AND STRIDE ACTIVELY

Stand and stride actively. Look forward with your head up and balanced. You should be standing up tall with feet on the pedals, grasping the handlebars.



CLIMBING ON AND OFF

Be careful when climbing on and off the elliptical trainer. Always grab the stationary handlebar for balance, and step on or off the pedals. The pedals will move when you put your weight on them, so it's best to have the pedal you step on first/step off last in the lowest position.



The Workout

With an elliptical trainer, you work your quadriceps, hamstrings, glutes, chest, back, triceps, biceps and more. The obvious benefit from exercising more muscles is that you tone more of your body while you burn more calories and fat—in less time. To get the full benefit of the dual action workout, it is important that you distribute the resistance between your upper and lower body. Many people who exercise on an elliptical trainer place most of the resistance on their lower body and only go through the motions with the upper handlebars.

- Wear appropriate footwear.
- Begin pedaling slowly with little or no resistance.
- Increase resistance gradually. You can simulate going up hills by increasing the resistance. Similarly, you can remove all resistance to sprint.
- Once you begin the pedal momentum, simply keep pedaling while the elliptical trainer automatically records your workout stats.
- Using the moving handlebars will give you a full-body workout, but it also takes some of the emphasis away from your lower body.
- Increase or decrease your resistance at any point, and feel free to switch between forward and backward pedaling (if your balance allows) throughout your workout.
- The elliptical trainer's stationary handlebar is there help you keep your balance when working lower body only.
- To get a better workout on your trunk and legs, drop your hands to your sides. This will demand more work on your core muscles as you strive to maintain balance while pedaling.
- As a beginner, you should be able to do 15 to 20 minutes at the lower settings. After just a few sessions using the elliptical trainer, you'll have the confidence and motivation to start increasing the intensity of your workout.
- Always cool down and stretch following your elliptical session.

OPERATIONAL INSTRUCTIONS

PEDAL CAP ADJUSTMENT

The position of the **PEDAL CAPS(78, 79)** can be adjusted by loosening the **LOCKING KNOBS(77)** and adjust the **PEDAL CAPS(78, 79)** to the front or back. Securely tighten the **LOCKING KNOBS(77)** after adjustment. Always set the **PEDAL CAPS(78, 79)** at the same position on both sides.

Start with the center position and adjust if necessary. Use the back position if users are taller than average. Use the front position if users are shorter than average. Find the position which is most comfortable for your exercise.

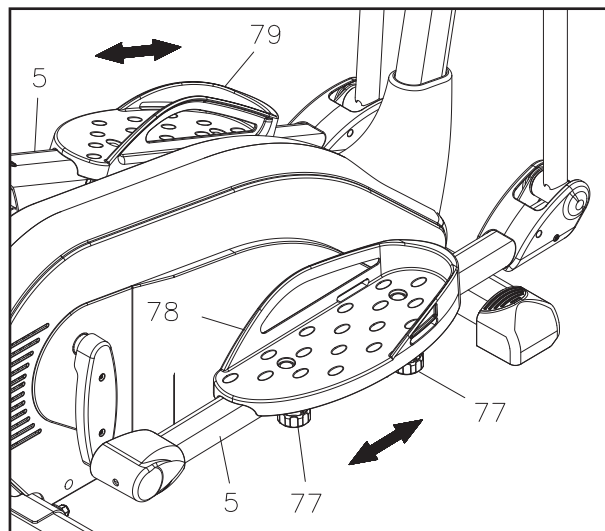

LOAD ADJUSTMENT

To increase the load, turn the **TENSION KNOB(22)** clockwise. To decrease the load, turn the **TENSION KNOB(22)** counterclockwise. There are eight levels for the load adjustment.

NOTE: The load will increase as you pedal faster.

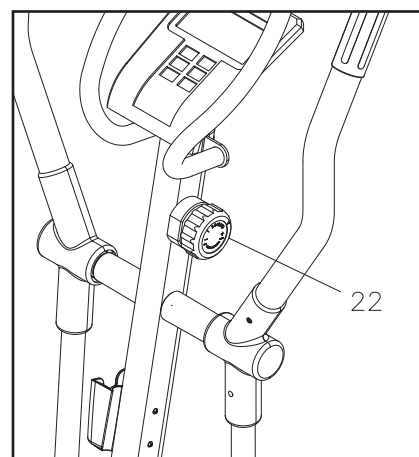

EXERCISE WORKOUT

To start using the **AVARI® 2000E Elliptical Trainer** simply stand on the foot pedals with the front of your shoes close to the front edge of the pedal cap. Place your hands at a comfortable position on the handlebars. Simply move your highest foot forward and follow the natural path of the machine.

Start on a load level that is comfortable to familiarize yourself with the machine. Once you are comfortable, start adjusting the load level to achieve the workout desired.

Forward and Reverse

The **AVARI® 2000E Elliptical Trainer** can be used in the forward and reverse direction to vary the muscles that you work out. This will also vary your workout, helping you to stay motivated. To change directions, simply slow the pedals down until they stop, and switch directions.

Load Level Adjustment

The load level of **AVARI® 2000E Elliptical Trainer** can be changed at any time during your workout. Adjusting your load level will allow you to increase or decrease your intensity level.

OPERATIONAL INSTRUCTIONS

USING THE FITNESS METER

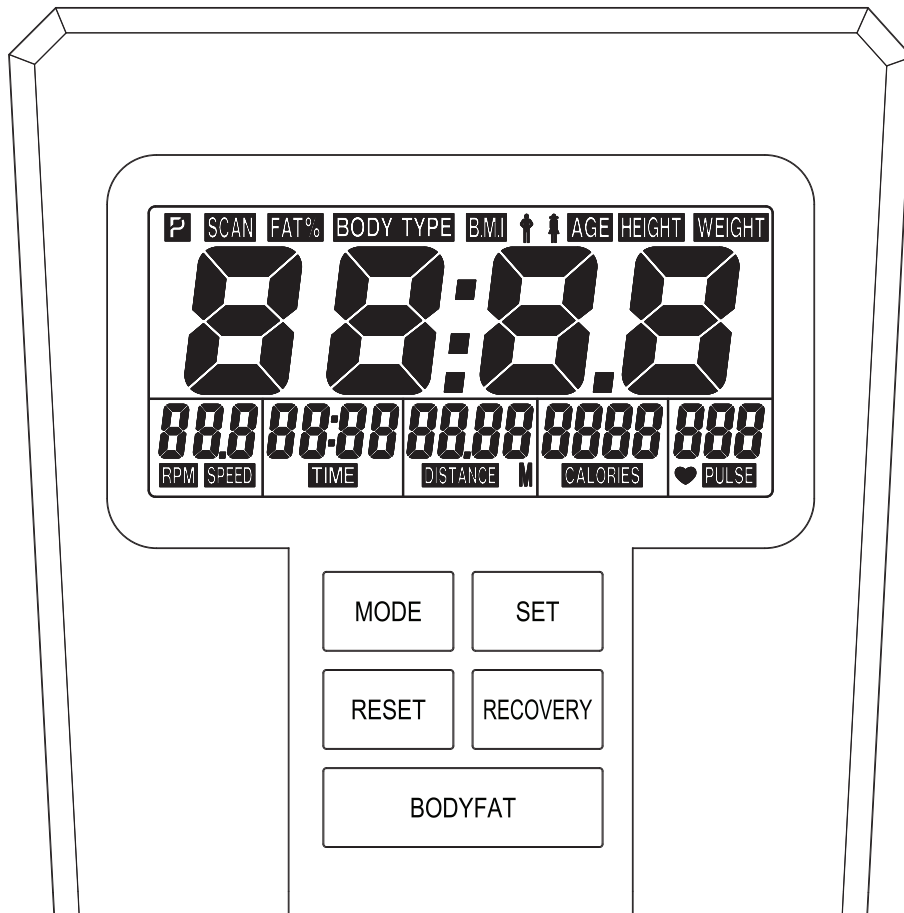

ACTIVITY MODE: Pedal movement or press any button.

SLEEP MODE: Automatically skips to Sleep mode after 4 minutes of inactivity. The Date, Time, and Temperature will be displayed on the screen.

FUNCTION BUTTONS:

MODE: Press and release to select each function for preset target values.

Press and release to select each function for display on Main Screen.

Press the button and hold it down for three seconds to reset all functions to zero and skip to setting mode.

Press the button and hold it down for five seconds to reset all functions to zero and skip to Personal Data setting mode.

SET: Press to set target values for TIME, DISTANCE, CALORIES, and PULSE. Input the Personal Data and setting the Date/Clock.

RESET: This button will reset each function to zero when setting the target value.

Press the button and hold it down for three seconds to reset all functions to zero and skip to setting mode.

RECOVERY: To activate the pulse recovery function after training, you have to input your personal data in advance for correct readout.

BODYFAT: Press to activate the body fat measurement function anytime. Input your personal data in advance for correct readout.

OPERATIONAL INSTRUCTIONS

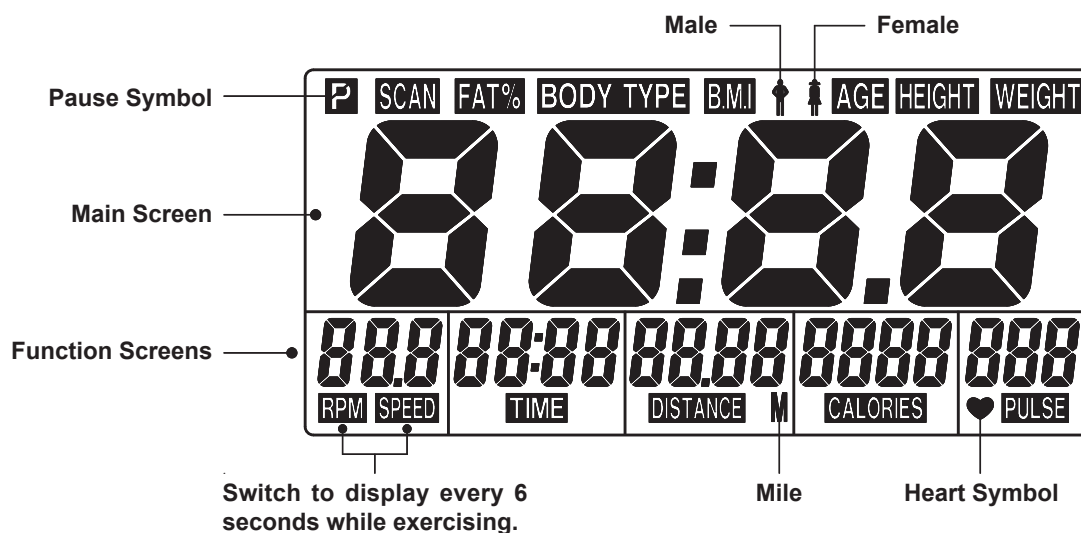

FUNCTIONS:

SCAN: Main screen automatically scans **RPM**, **SPEED**, **TIME**, **DISTANCE**, **CALORIES**, and **PULSE** in sequence with a change every six seconds. Press and release the **MODE** button until “**SCAN**” appears on display.

RPM: Displays the rotations per minute (RPM) of the crank from zero to 999 RPM.
NOTE: The **RPM** and **SPEED** display will switch every 6 seconds while exercising.

SPEED: Displays the current speed from zero to 99.9 miles per hour.

TIME: Counts upward to 99:59 in one second increments. Counts down from preset value.

DISTANCE: Displays distance up to 99.99 miles in increments of 0.01 miles. Counts down from preset value.

CALORIES: Displays the calorie consumption from zero to 999 Kcal. Counts down from preset value. The calories readout is an estimate for an average user. It should be used only as a comparison between workouts on this unit.

PULSE: Displays your pulse rate in beats per minute.
 Press **SET/RESET** buttons to input your target pulse value. When you are exercising, a blinking signal will notify you when you reach or exceed your target pulse value. Slow your exercise intensity gradually to stay within your target pulse zone.
 To display pulse, grasp the Pulse Sensors on the Handlebar, one in each hand. The heart symbol “♥” will begin blinking when the Meter senses your pulse. Your pulse will be displayed approximately five (5) seconds after the heart symbol is displayed. If the heart symbol does not appear, relax your grip or change your grip on the pulse sensors.

DATE/CLOCK: Displays hour and minute readings from 00:00 to 23:59 (24 hours mode).

TEMPERATURE: Displays the current environment temperature.

OPERATIONAL INSTRUCTIONS

OPERATION DESCRIPTIONS

A. DATE / CLOCK SET UP (Only can be done right after the batteries are installed.)

The Meter operates with two AAA batteries, the batteries are not included. The date and clock must be reset anytime batteries are replaced.

Install two AAA batteries into the Meter per instructions on page 21. The Meter will then display all items on the screen and a “beep” will sound for two seconds. The Date/Clock setting display will be blinking as shown in illustration 1. Press the **SET** button to set the date and clock. You can use the **RESET** button to go back to the preset value of each setting item. Press **MODE** button to confirm the setting and move to next setting.

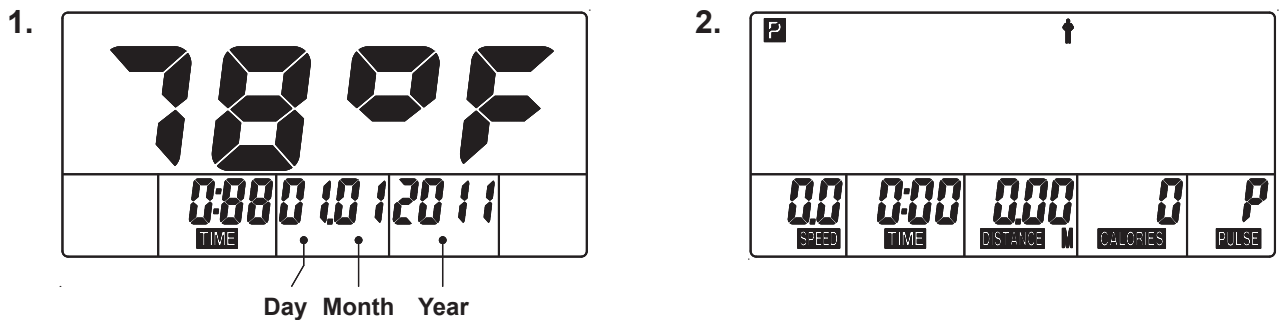

B. INPUT PERSONAL DATA (You may exit the setting by pressing the MODE button, and input your data later.)

Now, the display will look as illustration 2, shown the blinking Male symbol. Press the **SET** button to switch to Female symbol. Press **MODE** button to confirm your gender and move to next item. The Meter will go through the input items as follows and allow you to input your personal data.

Height (3 to 8 feet) → Weight (20 to 440 lbs) → Age (10 to 99 years old)

Use **SET** button to enter the values of your **HEIGHT**, **WEIGHT**, and **AGE**. Press **MODE** button to confirm the setting and move to next item for setting.

NOTE: You can input your personal data at any time. Press the **MODE** button and hold it down for five seconds to reset all functions to zero and skip to Personal Data setting mode.

C. BODY FAT MEASUREMENT (You may exit the body fat measurement by pressing the RESET button.)

Every time right after you input your personal data, the Meter will skip to body fat measurement mode automatically. The display will look as illustration 3. You have option to press the **RESET** button to quit the body fat measurement function. Or, press the **MODE** button and hold the pulse sensors on the Handlebar with both hands to do the body fat measurement. A few seconds later, the Meter will display the information for FAT%, BMI, and BODY TYPE cyclic for 75 seconds, refer to illustration 4. Press any button, except **BODYFAT** button, to exit the display.

NOTE: 1. Once you have correct personal data in the meter. You can simply press the **BODYFAT** button and hold the pulse sensors on the Handlebar with both hands to do the body fat measurement at any time.

2. If you do not hold properly or remove your hands from the Pulse Sensors. If no signal is available, an error code **E1** will displayed. Press the **BODYFAT** button and do the body fat measurement again.

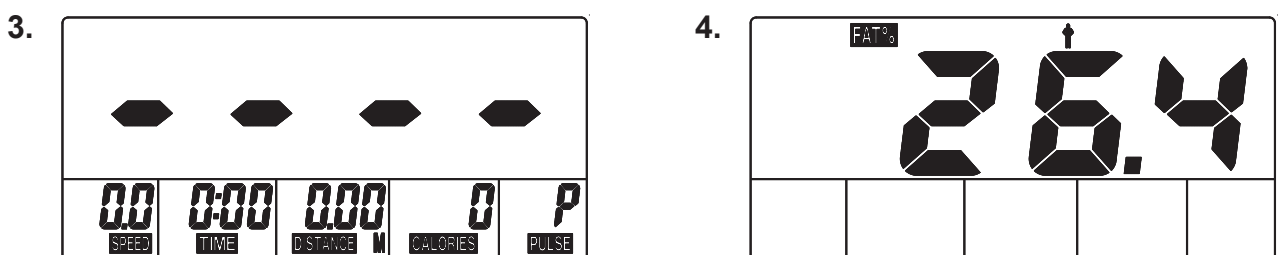

OPERATIONAL INSTRUCTIONS

UNDERSTANDING THE READOUT INFORMATION

1. BODY FAT %

Your body fat percentage is simply the percentage of fat your body contains. If you are 150 pounds and 10% fat, it means that your body consists of 15 pounds fat and 135 pounds lean body mass (bone, muscle, organ tissue, blood and everything else).

A certain amount of fat is essential to bodily functions. Fat regulates body temperature, cushions and insulates organs and tissues and is the main form of the body's energy storage. The table describes body fat ranges and their associated categories.

General Body Fat Percentage Categories		
Classification	Women (fat %)	Men (fat %)
Essential Fat	10 - 12%	2 - 4%
Athletes	14 - 20%	6 - 13%
Fitness	21 - 24%	14 - 17%
Acceptable	25 - 31%	18 - 25%
Obese	32% plus	25% plus

2. BMI (BODY MASS INDEX)

Body Mass Index is a height/weight formula used by health and weight professionals around the world to assess a person's body weight. From your body mass index number you can see if you are underweight, normal weight, overweight or obese.

BMI conclusions vary slightly according to gender. Here is a general summary of weight-status based on BMI.

Underweight	Under 20 (19 for women)
Normal Weight	Between 20 and 24.99
Overweight	Between 25 and 29.99
Obese Class 1	Between 30 and 34.99
Obese Class 2	Between 35 and 39.99
Extreme Obesity	40 and above

3. BODY TYPE

There are 9 BODY TYPES divided according to the FAT % calculated. Refer to the chart to determine what body type you are.

When you know which type you are and diet and exercise correctly for that type, you will make much better progress.

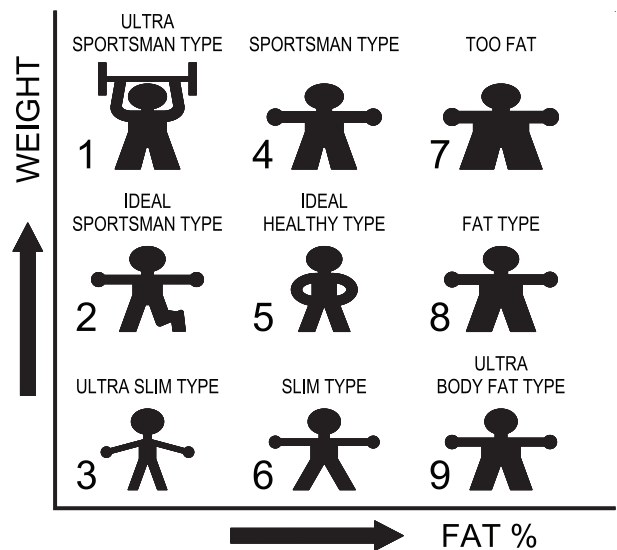

OPERATIONAL INSTRUCTIONS

D. PRESET FUNCTION VALUES

Stop pedaling for four seconds. Press the **MODE** or **RESET** button and hold it down for three seconds to reset all functions to zero and skip to setting mode, refer to illustration 5. Press the **MODE** button to select each function for preset target values. The Meter will cycle through the functions as follows and allow you to set the function values.

Time (0:00 to 99:00) → Distance (0.0 to 99.5 mile) → Calories (0 to 999 Kcal) → Target Pulse (72 to 240 bpm)

Use **SET/RESET** buttons to enter desired values of **TIME**, **DISTANCE**, **CALORIES**, and **PULSE**. Press **MODE** button to confirm the setting and move to next function for presetting. Or, just press the **MODE** button to pass the setting of some functions. Start to run the Meter functions by pedaling.

5.

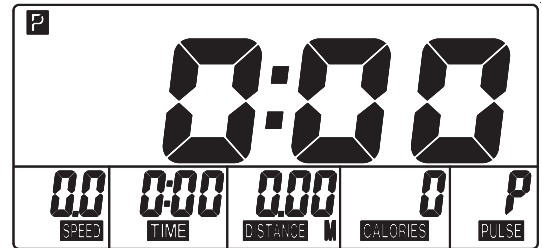

NOTE:

1. You may preset values for several functions. The preset function values will start to count down once you start pedaling. Preset values will only count down, they will not count up. When you complete one of the preset functions, the Meter will remind you with an audible alarm for ten seconds. Press any button to stop the audible alarm. Then the value of this completed function will start to count up, while the other preset functions will continue to count down.
2. The Meter will shut off automatically after 4 minutes of inactivity. All function values will be kept. Press the **MODE** or **RESET** button and hold it down for three seconds to reset all functions to zero and skip to setting mode.

E. PULSE RECOVERY FUNCTION (Input your personal data before using this function.)

The **PULSE RECOVERY** function measures how quickly you return to a resting pulse rate after exercising. You can use this function to measure improvement as you get into shape. The Meter will monitor your pulse for 60 seconds and calculate a Pulse Recovery value from **F1** to **F6**. **F1** is best. The readout should only be used as a comparison between workouts. It can be used right after any aerobic exercise. Stop exercising before starting this function.

To start the pulse recovery function, grasp the Pulse Sensors on the Handlebar, one in each hand. Your pulse will be displayed approximately five (5) seconds after the heart symbol is displayed. Then press the **RECOVERY** button and continue to grasp the Pulse Sensors correctly. During the pulse recovery function, only **PULSE** and **TIME** are working and the display will be as shown in illustration 6. **TIME** will count down from 0:60 and the heart symbol will be blinking. When the **TIME** reaches 0, the Meter will show your pulse recovery condition from **F1.0** to **F6.0**. See illustration 7. Press the **RECOVERY** button to exit the pulse recovery function and skip to Activity Mode.

- NOTE:**
1. You can quit the pulse recovery function at any time by pressing the **RECOVERY** button. The Meter will skip to Activity Mode.
 2. Once the pulse recovery function starts, the **TIME** will count down from 60 seconds to zero even if you remove your hands from the Pulse Sensors. If no pulse signal is available, **F6.0** will displayed as the pulse recovery condition.

6.

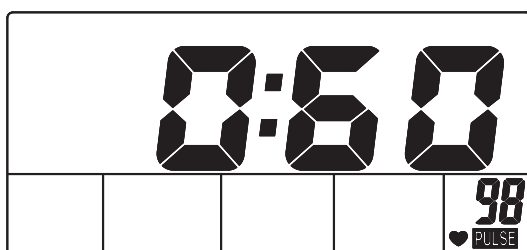

7.

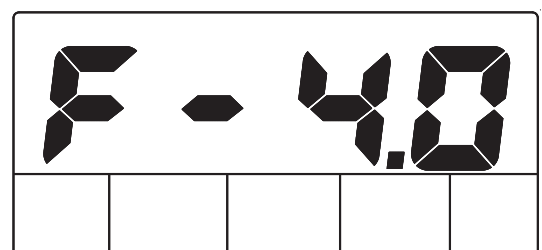

OPERATIONAL INSTRUCTIONS

HOW TO INSTALL AND REPLACE BATTERIES:

1. Open the Battery Door on the back of the **METER(25)**.
2. The **METER(25)** operates with two AAA batteries, the batteries are not included. Refer to the illustration to install or replace the batteries.

NOTE:

1. Do not mix a new battery with an old battery.
2. Use the same type of battery. Do not mix an alkaline battery with another type of battery.
3. Rechargeable batteries are not recommended.

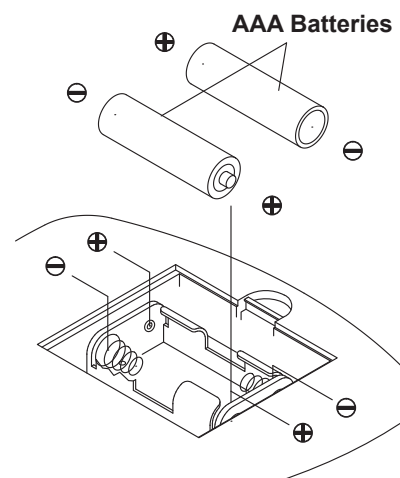

STORAGE

1. To store the **AVARI® 2000E Elliptical Trainer**, simply keep it in a clean dry place.
2. The minimum rest dimensions of the **AVARI® 2000E Elliptical Trainer** are approximately 48 inches long x 25.4 inches wide x 60 inches tall. These dimensions may vary. Please measure your **AVARI® 2000E Elliptical Trainer** if exact dimensions are needed.
3. Move the **AVARI® 2000E Elliptical Trainer** with the moving wheels on the **FRONT STABILIZER(3)**. Grasp the **STATIONARY HANDLEBAR(11)** on the **UPRIGHT(4)**, tip the **AVARI® 2000E Elliptical Trainer** forward and move slowly.
4. To avoid damage to the electronics, remove the batteries before storing the **AVARI® 2000E Elliptical Trainer** for one year or more.

MAINTENANCE

The safety and integrity designed into the **AVARI® 2000E Elliptical Trainer** can only be maintained when the **AVARI® 2000E Elliptical Trainer** is regularly examined for damage and wear. Special attention should be given to the following:

1. Adjust the **TENSION KNOB(22)** and verify that the resistance changes.
2. Verify that all nuts and bolts are present and properly tightened. Replace missing nuts and bolts. Tighten loose nuts and bolts.
3. Verify that the **WARNING LABEL(95)** is in place and easy to read. Call Stamina Products immediately at **1-800-375-7520** for a replacement **WARNING LABEL(95)** if it is missing or damaged.
4. It is the sole responsibility of the user/owner to ensure that regular maintenance is performed.
5. Worn or damaged components shall be replaced immediately or the **AVARI® 2000E Elliptical Trainer** removed from service until repair is made.
6. Only Stamina Products supplied components shall be used to maintain/repair the **AVARI® 2000E Elliptical Trainer**.
7. Keep your **AVARI® 2000E Elliptical Trainer** clean by wiping it off with an absorbent cloth after use.

CONDITIONING GUIDELINES

How you begin your exercise program depends on your physical condition. If you have been inactive for several years or are severely overweight, start slowly and increase your workout time gradually. Increase your workout intensity gradually by monitoring your heart rate while you exercise.

Remember to follow these essentials:

- Have your doctor review your training and diet programs.
- Begin your training program slowly with realistic goals that have been set by you and your physician.
- Warm up before you exercise and cool down after you work out.
- Take your pulse periodically during your workout and strive to stay within a range of 60% (lower intensity) to 90% (higher intensity) of your maximum heart rate zone. Start at the lower intensity, and build up to higher intensity as you become more aerobically fit.
- If you feel dizzy or lightheaded you should slow down or stop exercising.

Initially you may only be able to exercise within your target zone for a few minutes; however, your aerobic capacity will improve over the next six to eight weeks. It is important to pace yourself while you exercise so you don't tire too quickly.

To determine if you are working out at the correct intensity, use a heart rate monitor or use the table below. For effective aerobic exercise, your heart rate should be maintained at a level between 60% and 90% of your maximum heart rate. If just starting an exercise program, work out at the low end of your target heart rate zone. As your aerobic capacity improves, gradually increase the intensity of your workout by increasing your heart rate.

Measure your heart rate periodically during your workout by stopping the exercise but continuing to move your legs or walk around. Place two or three fingers on your wrist and take a six second heartbeat count. Multiply the results by ten to find your heart rate. For example, if your six second heartbeat count is 14, your heart rate is 140 beats per minute. A six second count is used because your heart rate will drop rapidly when you stop exercising. Adjust the intensity of your exercise until your heart rate is at the proper level.

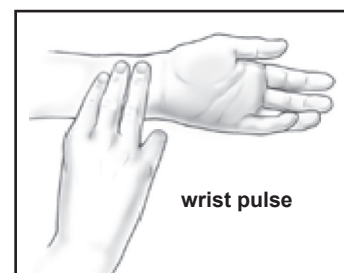

Target Heart Rate Zone Estimated by Age*

Age	Target Heart Rate Zone (55%-90% of Maximum Heart Rate)	Average Maximum Heart Rate 100%
20 years	110-180 beats per minute	200 beats per minute
25 years	107-175 beats per minute	195 beats per minute
30 years	105-171 beats per minute	190 beats per minute
35 years	102-166 beats per minute	185 beats per minute
40 years	99-162 beats per minute	180 beats per minute
45 years	97-157 beats per minute	175 beats per minute
50 years	94-153 beats per minute	170 beats per minute
55 years	91-148 beats per minute	165 beats per minute
60 years	88-144 beats per minute	160 beats per minute
65 years	85-139 beats per minute	155 beats per minute
70 years	83-135 beats per minute	150 beats per minute

* For cardiorespiratory training benefits, the American College of Sports Medicine recommends working out within a heart rate range of 55% to 90% of maximum heart rate. To predict the maximum heart rate, the following formula was used: $220 - \text{Age} = \text{predicted maximum heart rate}$

WARM-UP and COOL-DOWN

Warm-Up The purpose of warming up is to prepare your body for exercise and to minimize injuries. Warm up for two to five minutes before strength training or aerobic exercising. Perform activities that raise your heart rate and warm the working muscles. Activities may include brisk walking, jogging, jumping jacks, jump rope, and running in place.

Stretching Stretching while your muscles are warm after a proper warm-up and again after your strength or aerobic training session is very important. Muscles stretch more easily at these times because of their elevated temperature, which greatly reduces the risk of injury. Stretches should be held for 15 to 30 seconds. Do not bounce.

Suggested Stretching Exercises

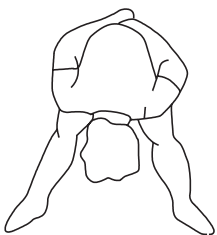

Lower Body Stretch

Place feet shoulder-width apart and lean forward. Keep this position for 30 seconds using the body as a natural weight to stretch the backs of the legs. **DO NOT BOUNCE!** When the pull on the back of the legs lessens, gradually try a lower position.

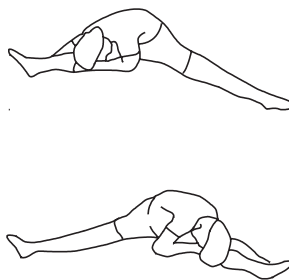

Floor Stretch

While sitting on the floor, open the legs as wide as possible. Stretch the upper body toward the knee on the right leg by using your arms to pull your chest to your thighs. Hold this stretch 10 to 30 seconds. **DO NOT BOUNCE!** Do this stretch 10 times. Repeat the stretch with the left leg.

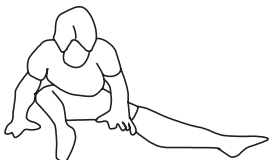

Bent Torso Pulls

While sitting on the floor, have legs apart, one leg straight and one knee bent. Pull the chest down to touch the thigh on the leg that is bent, and twist at the waist. Hold this position at least 10 seconds. Repeat 10 times on each side.



Bent Over Leg Stretch

Stand with feet shoulder-width apart and lean forward as illustrated. Using the arms, **gently** pull the upper body towards the right leg. Let the head hang down. **DO NOT BOUNCE!** Hold the position a minimum of 10 seconds. Repeat pulling the upper body to the left leg. Do this stretch several times slowly.

Remember to always check with your physician before starting any exercise program.

Cool-Down The purpose of cooling down is to return the body to its normal, or near normal, resting state at the end of each exercise session. A proper cool-down slowly lowers your heart rate and allows blood to return to the heart. Your cool-down should include the stretches listed above and should be completed after each strength training session.

PRODUCT PARTS DRAWING

FRONT

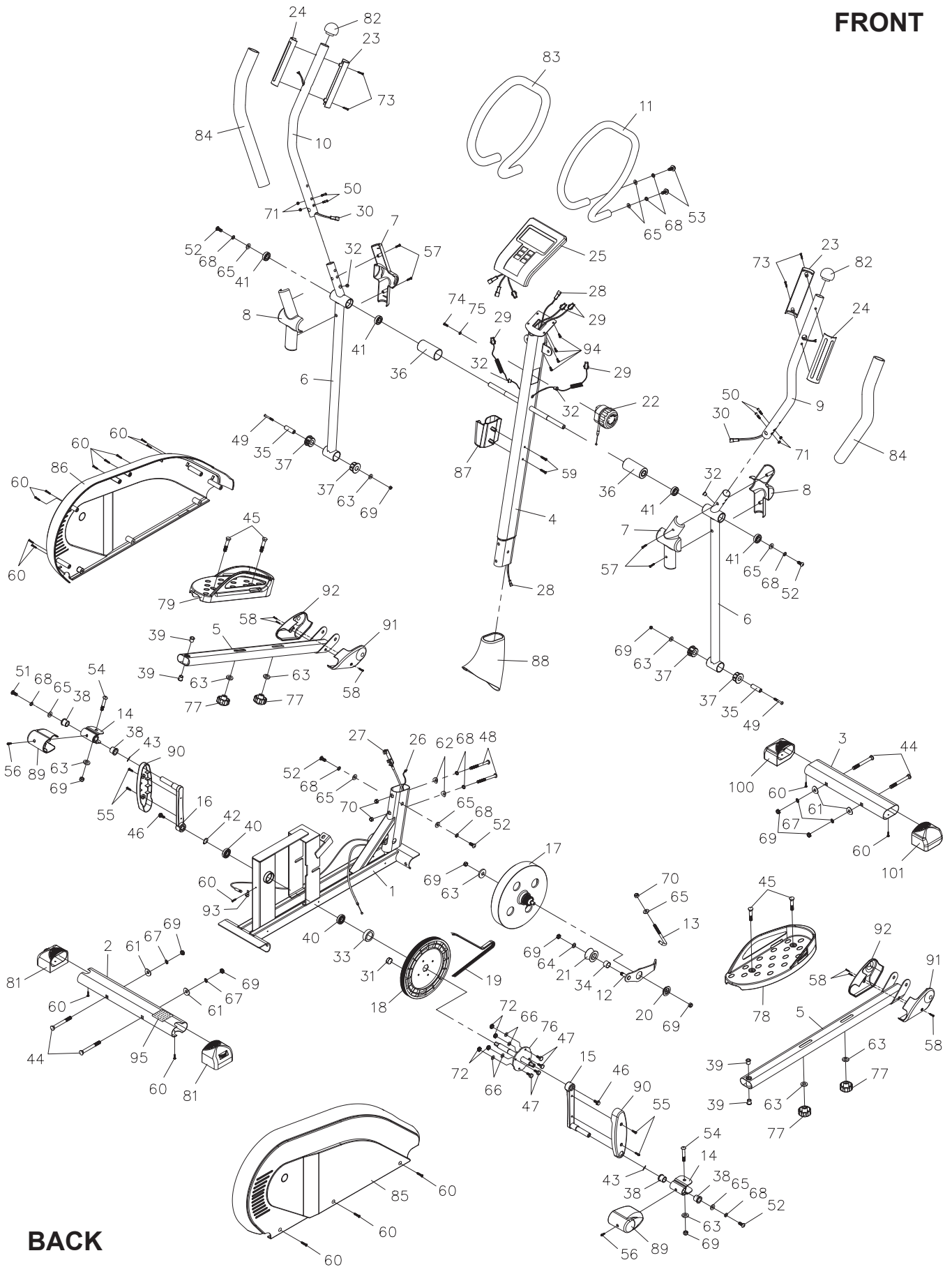

BACK

PARTS LIST

PART#	PART NAME	QTY
1	Main Frame	1
2	Rear Stabilizer	1
3	Front Stabilizer	1
4	Upright	1
5	Pedal Arm	2
6	Pivoting Arm	2
7	Front Pivot Cover	2
8	Rear Pivot Cover	2
9	Right Handlebar	1
10	Left Handlebar	1
11	Stationary Handlebar	1
12	Idler Arm	1
13	Tension Adjustment Hook	1
14	Pedal Arm Connector	2
15	Right Crank	1
16	Left Crank	1
17	Magnetic Unit	1
18	Pulley	1
19	V-Ribbed Belt	1
20	Idler Arm Bushing	1
21	Idler Wheel	1
22	Tension Knob	1
23	Pulse Sensor Cover	2
24	Pulse Sensor	2
25	Meter	1
26	Sensor Wire	1
27	Tension Cable	1
28	Connection Wire	1
29	Pulse Connection Wire	2
30	Pulse Sensor Wire	2
31	Magnet	1
32	Grommet Plug	4
33	Pulley Spacer	1
34	Idler Wheel Spacer	1
35	Shaft	2
36	Spacer	2
37	Low Pivoting Arm Bushing	4
38	Connector Bushing	4
39	Pedal Arm Bushing	4
40	Bearing (6003zz)	2
41	Bearing (6002zz)	4
42	C Ring (17mm)	1
43	Wave Washer	2
44	Carriage Bolt (M10 x 1.5 x 94mm)	4
45	Carriage Bolt (M10 x 1.5 x 50mm)	4
46	Flange Bolt (5/16 - 18 x 1")	2
47	Bolt, Hex Head (M6 x 1 x 18mm)	4
48	Bolt, Button Head (M8 x 1.25 x 88mm)	2
49	Bolt, Button Head (M10 x 1.5 x 76mm)	2
50	Bolt, Button Head (M8 x 1.25 x 36mm)	4

PARTS LIST

PART#	PART NAME	QTY
51	Bolt, Button Head (M8 x 1.25 x 20mm, Left Hand Threads)	1
52	Bolt, Button Head (M8 x 1.25 x 20mm)	5
53	Bolt, Button Head (M8 x 1.25 x 25mm)	2
54	Bolt, Button Head (M10 x 1.5 x 50mm)	2
55	Screw, Round Head (M5 x 0.8 x 16mm)	4
56	Screw, Small Round Head (M5 x 0.8 x 10mm)	2
57	Screw, Small Round Head (M4 x 35mm)	4
58	Screw, Small Round Head (M4 x 20mm)	6
59	Screw, Round Head (M4 x 30mm)	2
60	Screw, Round Head (M4 x 20mm)	17
61	Arc Washer (M10)	4
62	Arc Washer (M8)	2
63	Washer (M10)	9
64	Small Washer (M10 x ø14 x 2mm thick)	1
65	Washer (M8)	9
66	Washer (M6)	4
67	Lock Washer (M10)	4
68	Lock Washer (M8)	10
69	Nylock Nut (M10 x 1.5)	11
70	Nylock Nut (M8 x 1.25 x 8mm thick)	3
71	Thin Nylock Nut (M8 x 1.25 x 6.35mm thick)	4
72	Nylock Nut (M6 x 1)	4
73	Screw, Small Round Head (M3 x 12mm)	4
74	Screw, Round Head (M5 x 0.8 x 25mm)	1
75	Washer (M5)	1
76	Axle	1
77	Locking Knob	4
78	Right Pedal Cap	1
79	Left Pedal Cap	1
81	Adjustable Endcap	2
82	Dome Plug (ø50mm)	2
83	Stationary Handlebar Foam Tube	1
84	Handlebar Foam Tube	2
85	Right Cover	1
86	Left Cover	1
87	Tray	1
88	Upright Sleeve	1
89	Connector Cover	2
90	Crank Cover	2
91	Right Pedal Arm Cover	2
92	Left Pedal Arm Cover	2
93	Sensor Clip	1
94	Screw, Round Head (M5 x 0.8 x 10mm)	4
95	Warning Label	1
96	Allen Wrench (5mm)	1
97	Allen Wrench (6mm)	1
98	Socket Wrench	1
99	Manual	1
100	Left Endcap	1
101	Right Endcap	1

LIMITED WARRANTY

MODEL A550-110A

WARRANTY

Stamina Products, Inc. warrants that this product will be free from defects in materials and workmanship under normal use, service, proper assembly and proper operation for a period of 90 days on the parts and three years on the frame from the date of the original purchase from an authorized retailer. **THIS WARRANTY SHALL NOT APPLY TO ANY PRODUCT WHICH HAS BEEN SUBJECT TO COMMERCIAL USE, ABUSE, MISUSE, ALTERATION OF ANY TYPE OR CAUSE OR TO ANY DEFECT OR DAMAGE CAUSED BY IMPROPER ASSEMBLY, REPAIR, REPLACEMENT, SUBSTITUTION OR USE WITH PARTS OTHER THAN PARTS PROVIDED BY STAMINA PRODUCTS, INC.** Commercial use includes use of the product in athletic clubs, health clubs, spas, gymnasiums, exercise facilities, and other public or semipublic facilities whether or not the product's use is in furtherance of a profit making enterprise, and all other use which is not for personal, family, or household purposes.

To implement this limited warranty, send a written notice stating your name, date, and place of purchase and a brief description of the defect along with your receipt to **Stamina Products, Inc. P.O. Box 1071, Springfield Missouri, USA, 65801-1071**, or email us at **customerservice@staminaproducts.com**, or call us at **1-800-375-7520**. If the defect is covered under this limited warranty, you will be requested to return the product or part to us for free repair or replacement at our option. **NO ACTION FOR BREACH OF THIS LIMITED WARRANTY MAY BE COMMENCED MORE THAN ONE (1) YEAR AFTER THE DATE THE ALLEGED BREACH WAS OR SHOULD HAVE BEEN DISCOVERED. NO ACTION FOR BREACH OF ANY IMPLIED WARRANTY MAY BE COMMENCED MORE THAN ONE (1) YEAR AFTER DELIVERY OF THE PRODUCT TO THE PURCHASER.** This limited warranty is not transferable. **IF ANY PART OF THE PRODUCT IS NOT IN COMPLIANCE WITH THIS LIMITED WARRANTY OR ANY IMPLIED WARRANTY, THE REMEDY OF REPAIR OR REPLACEMENT IS THE EXCLUSIVE REMEDY AVAILABLE TO YOU.** In the event that the purchaser makes any claim under this limited warranty or any implied warranty, the Warrantor reserves the right to require the product to be returned for inspection, at the purchaser's expense, to the Warrantor's premises in Springfield, Missouri. Return of the enclosed warranty registration card is not required for warranty coverage, but is merely a way of establishing the date and place of purchase.

Stamina Products, Inc. **SHALL NOT BE LIABLE FOR THE LOSS OF USE OF ANY PRODUCT, LOSS OF TIME, INCONVENIENCE, COMMERCIAL LOSS OR ANY OTHER INDIRECT, CONSEQUENTIAL, SPECIAL OR INCIDENTAL DAMAGES DUE TO BREACH OF THE ABOVE WARRANTY OR ANY IMPLIED WARRANTY.**

This limited warranty is the only written or express warranty given by Stamina Products, Inc. This warranty gives you specific legal rights, and you may also have other legal rights which vary from state to state. **ANY OTHER RIGHT WHICH YOU MAY HAVE, INCLUDING ANY IMPLIED WARRANTY OR MERCHANTABILITY OR FITNESS FOR A PARTICULAR PURPOSE, IS LIMITED IN DURATION TO THE DURATION OF THIS WARRANTY.**

The laws in some jurisdictions restrict the rights of manufacturers and distributors of consumer goods to disclaim or limit implied warranties and consequential and incidental damages with respect thereto. If any such law is found to be applicable, the foregoing disclaimers and limitations of and on implied warranties and consequential and incidental damages with respect thereto shall be disregarded and shall be deemed not to have been made to the extent necessary to comply with such legal restriction.

NOTES

NOTES

TO CONTACT CUSTOMER SERVICE

For your convenience, Stamina's customer service representatives can be reached by email at customerservice@staminaproducts.com or by phone at 1-800-375-7520 (in the U.S.). Our customer service representatives are available Monday through Thursday from 7:30 a.m. until 5:00 p.m., and Friday 8:00 a.m. until 3 p.m. Central Time.



**ONLINE
CUSTOMER SERVICE**
customerservice@staminaproducts.com
www.staminaproducts.com



**TELEPHONE
CUSTOMER SERVICE**
Tel: 1 (800) 375-7520



**FAX
CUSTOMER SERVICE**
Fax: (417) 889-8064



**MAIL
STAMINA PRODUCTS, INC.**
ATTN: Customer Service
P.O. Box 1071 Springfield, MO. 65801-1071

Would you like to receive email information or special offers from Stamina Products? Register at contact.staminaproducts.com

TO REGISTER YOUR PRODUCT

To enact your warranty, please register your product by going to register.staminaproducts.com. Please have your product model number (printed on the cover of this owner's manual) and the serial number (printed on the black and white sticker on your product) ready.

If you don't have internet access, you can call customer service at 1-800-375-7520, or fill out and mail the product registration form below to Stamina Products, Inc.; P.O. Box 1071; Springfield, MO 65801-1071.

PRODUCT REGISTRATION FORM	Stamina Products, Inc. P.O. Box 1071 Springfield, MO 65801-1071
Model Number:	Serial Number:
Product Name:	
Place Purchased:	
Date of Purchase:	Purchase Price:
First Name:	Last Name:
City:	State: Zip Code:
Email Address:	Phone #: ()
Would you like to receive email information or special offers from Stamina Products?* <input type="checkbox"/> Yes <input type="checkbox"/> No *If yes, be sure your email address is included above.	



Detach and Mail or Fax the Form Above



TO ORDER PARTS

If there are missing or damaged parts, you can go to parts.staminaproducts.com and order those parts. If you have questions, please contact customer service. Do not return the product. To order parts by mail, fill out the sheet below and fax it to 417-889-8064. The part will be mailed to your address.



Detach and Mail or Fax the Form Below



PARTS ORDER FORM	Stamina Products, Inc. P.O. Box 1071 Springfield, MO 65801-1071
Mr./Ms:	
Address: Apt. #:	
City: State: Zip Code:	
IMPORTANT : We must have your phone number to process the order!	
Phone #: () Work Phone #: ()	
Date of Purchase:	
Model #:	
Purchased From:	

**IMPORTANT : Before filling out the form below make sure you have the correct information.
Refer to the parts list to make sure you're ordering the right parts!**

PART #	DESCRIPTION	QUANTITY
EXAMPLE: 1	Rear Unit Assembly	1