

PARTS LIST			
LETTER CODE	DESCRIPTION	QTY.	PART NO.
A	Left Side Panel	1	1854-02
B	Right Side Panel	1	1854-03
C	Screw Post	18	HFFMFB
D	Left Cabinet Rail	1	1970-15
E	Pointed Screw	4	1902-23
F	Right Cabinet Rail	1	1970-16
G	Top Panel	1	1854-01
H	Back Panel	1	1854-04
I	Bottom Panel	1	1854-05
J	Locking Cam	18	HFFMFC
K	Wood Dowel	4	H8MMDWL
L	Half-Shelf	1	1854-07
M	Small Machine Screw	4	1854-28
N	Hinge Bracket (Style 1)	1	1854-29
O	Hinge Bracket (Style 2)	1	1854-30
P	Door	1	1854-08
Q	Bushing	2	1854-31
R	Lock (2 Keys not shown)	1	1854-13
S	Large Nut	1	1854-24
T	Caster Bracket	4	1854-10
U	Barrel Nut	8	1854-23
V	Bolt	8	1854-27
W	Lock Washer	8	1854-21
X	Caster	4	8917-25
Y	Shelf Peg	4	HSFBNZ
Z	Adjustable Shelf	1	1854-06
AA	Drawer	1	1854-09

ASSEMBLY INSTRUCTIONS

TOOLS REQUIRED: Phillips Screwdriver; Hammer or Mallet

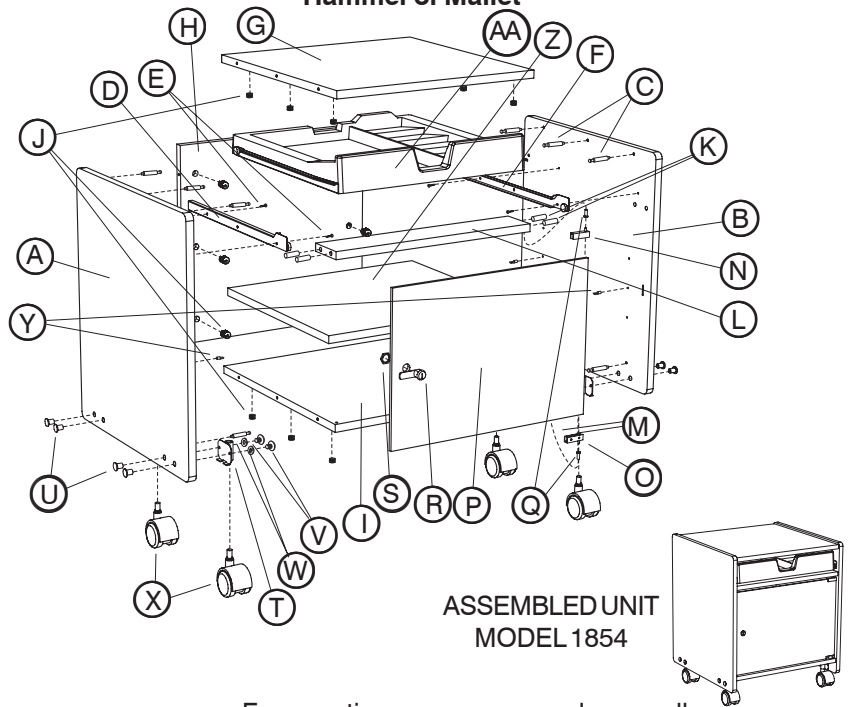

For questions or concerns, please call **Safco Consumer Hot Line 1-800-664-0042** available Monday-Friday 8:00 AM to 4:30 PM (Central Time) (English-speaking operators)

Properly identify the two rails used!

The (D) Left Cabinet Rail is stamped "CL" near the roller, while the (F) Right Cabinet Rail is stamped "CR".

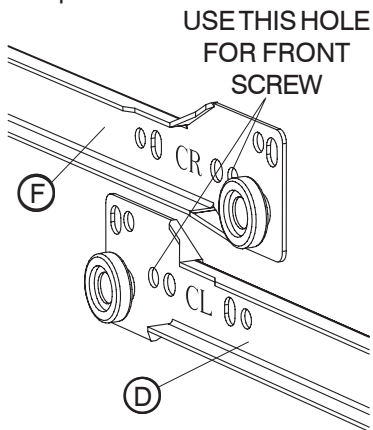

1 Work on a smooth, clean surface.

Locate the (A) Left Side Panel and the (B) Right Side Panel and position them with the holes up, as shown below. Insert (C) Screw Posts into the holes along the top, back and bottom of each panel, and tighten with a screwdriver (do not overtighten!)

Attach the (D) Left Cabinet Rail to the (A) Left Side Panel, with the roller facing the front edge, using two (E) Pointed Screws (start with the hole closest to the roller). Do the same with the (F) Right Cabinet Rail on the (B) Right Side Panel.

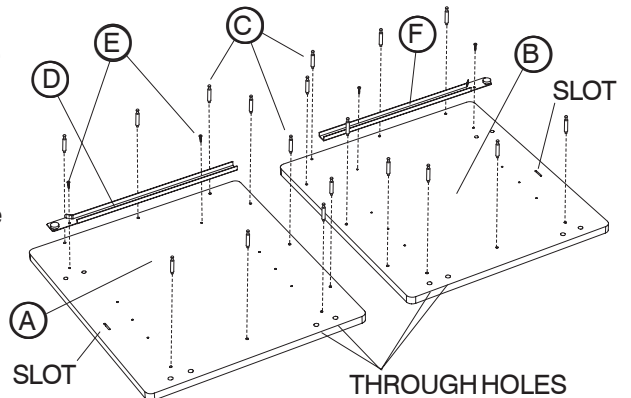

2 The (G) Top Panel has two finished edges, the (H) Back Panel has no finished edges, and the (I) Bottom Panel has one finished edge. Lay them down with the large holes facing up. Insert six (J) Locking Cams into each panel, with the arrows pointing toward the nearest SIDE edge.

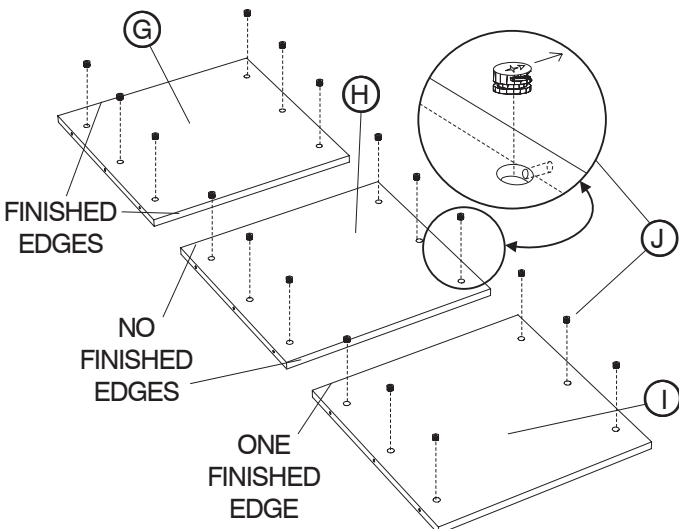

3 Insert the four (K) Wood Dowels into the holes in the ends of the (L) Half-Shelf. Tap with a hammer or mallet until they are fully seated.

Using two (M) Small Machine Screws each, attach the (N) and (O) Hinge Brackets to the corners of the (P) Door, opposite the large hole. Make sure that the posts on the Brackets are closest to the corner. Slip a (Q) Bushing over each post.

From the face of the Door OPPOSITE the screws in the Hinge Brackets, insert the (R) Lock through the large hole, and fasten with the (S) Large Nut so that the pawl points straight out to the side. Once securely fastened, turn the Lock with the Key so the pawl is parallel to the edge.

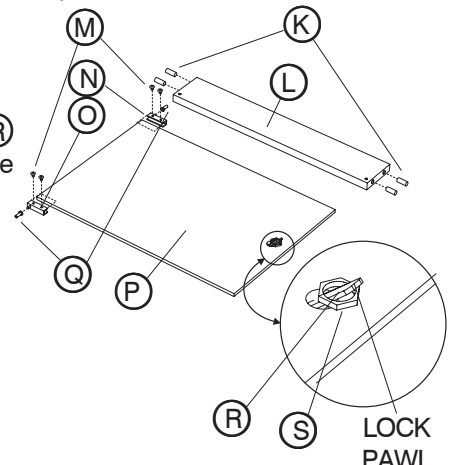

4 Depending on whether you want the Door to hinge on the left or on the right, select the Side Panel OPPOSITE the hinge side (both options are shown in this and the next two steps). Slide the Top, Back and Bottom Panels down onto the Screw Posts, and secure by turning each of the engaged cams clockwise until they stop.

FOR HINGE AT RIGHT SIDE

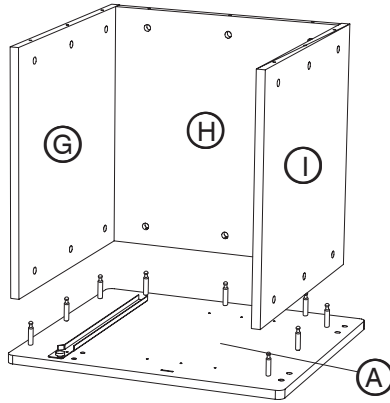

OR

FOR HINGE AT LEFT SIDE

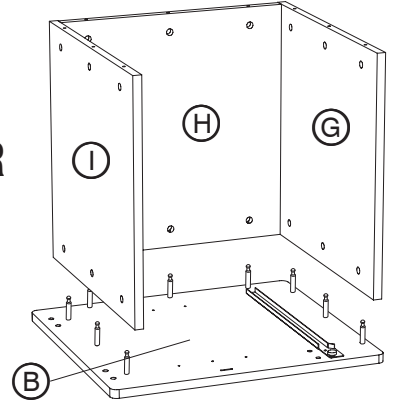

5 With the holes on its underside facing the front and bottom of the unit, insert the Wood Dowels of the (L) Half-Shelf into the holes in the Side Panel; tilt the Half-Shelf enough to insert the Bushings on the (P) Door into the hole in the Half-Shelf and the hole in the Bottom Panel. Straighten the Half-Shelf.

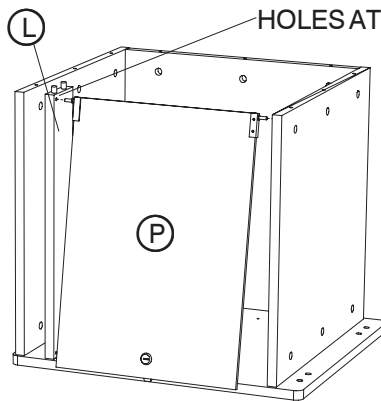

OR

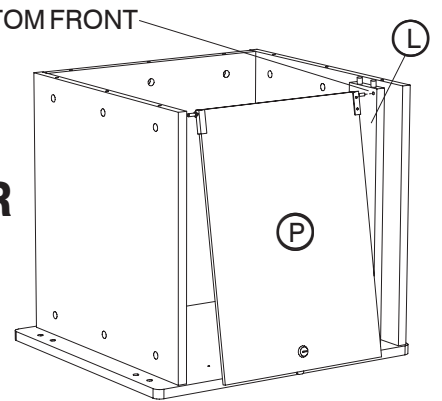

6 Slide the Screw Posts on the remaining Side Panel into the corresponding holes in the Top, Back and Bottom Panels (making sure that the Wood Dowels also engage), and lock all Cams.

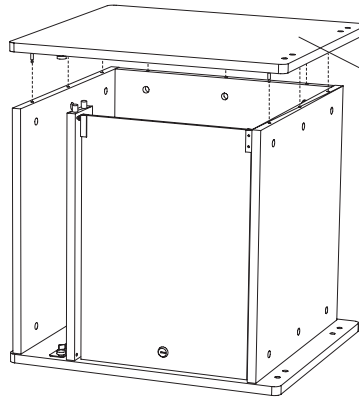

OR

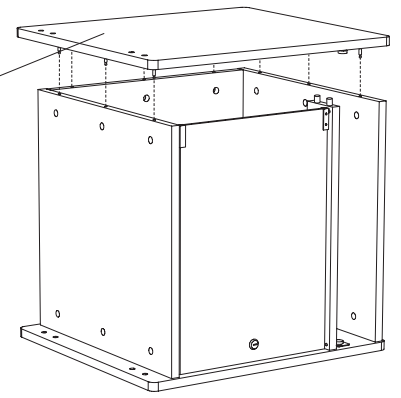

7 Turn the unit onto its back. At each set of holes along the bottom edges, position a (T) Caster Bracket, and fasten with (U) Barrel Nuts (from the outside) and (V) Bolts and (W) Lock Washers (from the inside). Push a (X) Caster into each Caster Bracket, and set the unit upright.

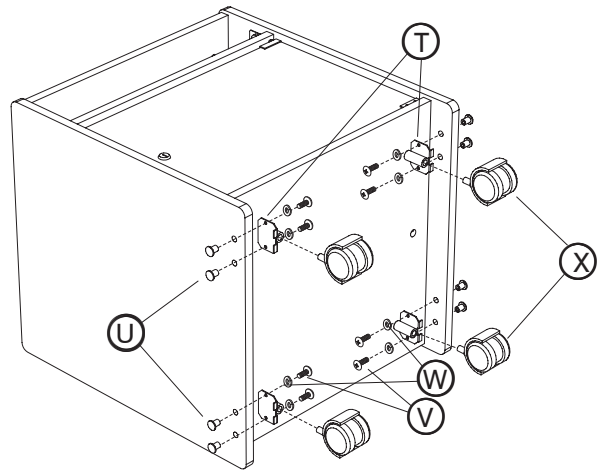

8 Insert four (Y) Shelf Pegs into the holes at the desired shelf height; tilt the (Z) Adjustable Shelf to get it through the Door, then set it on the Shelf Pegs.

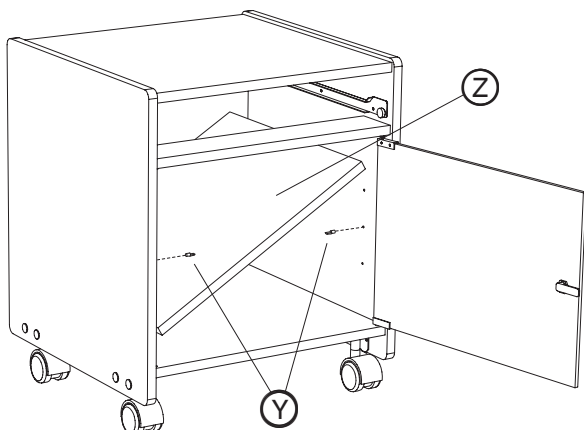

9 Install the (AA) Drawer: lift the back rollers on the Drawer Rails over the front rollers on the Cabinet Rails, tilt the Drawer enough to start the Drawer moving, and lower the Drawer to push it all the way into place.

