

an LDI Company
New Hope, MN 55428
Visit us on the web:
www.safcoproducts.com

ASSEMBLY INSTRUCTIONS

READ THESE INSTRUCTIONS BEFORE STARTING! FOLLOW THE ASSEMBLY PROCEDURES CAREFULLY.

PRODUCT WARRANTY REGISTRATION is available online at: www.safcoproducts.com

Tools required: Phillips screwdriver, hammer
(nail or pointed tool may be used to help start holes)

PARTS LIST

LETTER CODE	DESCRIPTION	QTY.	PART NO.	LETTER CODE	DESCRIPTION	QTY.	PART NO.	LETTER CODE	DESCRIPTION	QTY.	PART NO.
(A)	Left Frame Assembly	1	3957-51BL	(H)	TubePlug	8	3957-76BL	(O)	Leveler	4	3957-75NC
(B)	Right Frame Assembly	1	3957-52BL	(I)	Large Flat Head Machine Screw	2	3957-77NC	(P)	Drawing Board Support Bar	2	3957-65BL
(C)	Back Panel	1	3957-53BL	(J)	Long Pan Head Machine Screw	16	3957-78NC	(Q)	Pencil Bar	1	3957-83BL
(D)	Horizontal Tube	2	3957-54BL	(K)	Pan Head Hi-Grip Screw	18	3957-79NC	(R)	Short Pan Head Machine Screw	2	3957-74NC
(E)	Lift Bar	1	3957-55BL	(L)	Nylon Spacer	4	3957-82NC	*Table Tops below sold & shipped separately			
(F)	Left Support Channel	1	3957-60BL	(M)	Washer	2	3957-71NC	(S)	Drawing Board – 60"	1	3948*
(G)	Right Support Channel	1	3957-61BL	(N)	Adjustment Knob, Black	2	3957-73BL	(T)	Drawing Board – 48"	1	3951*

(S) (T) TABLE TOP (SOLD SEPARATELY)

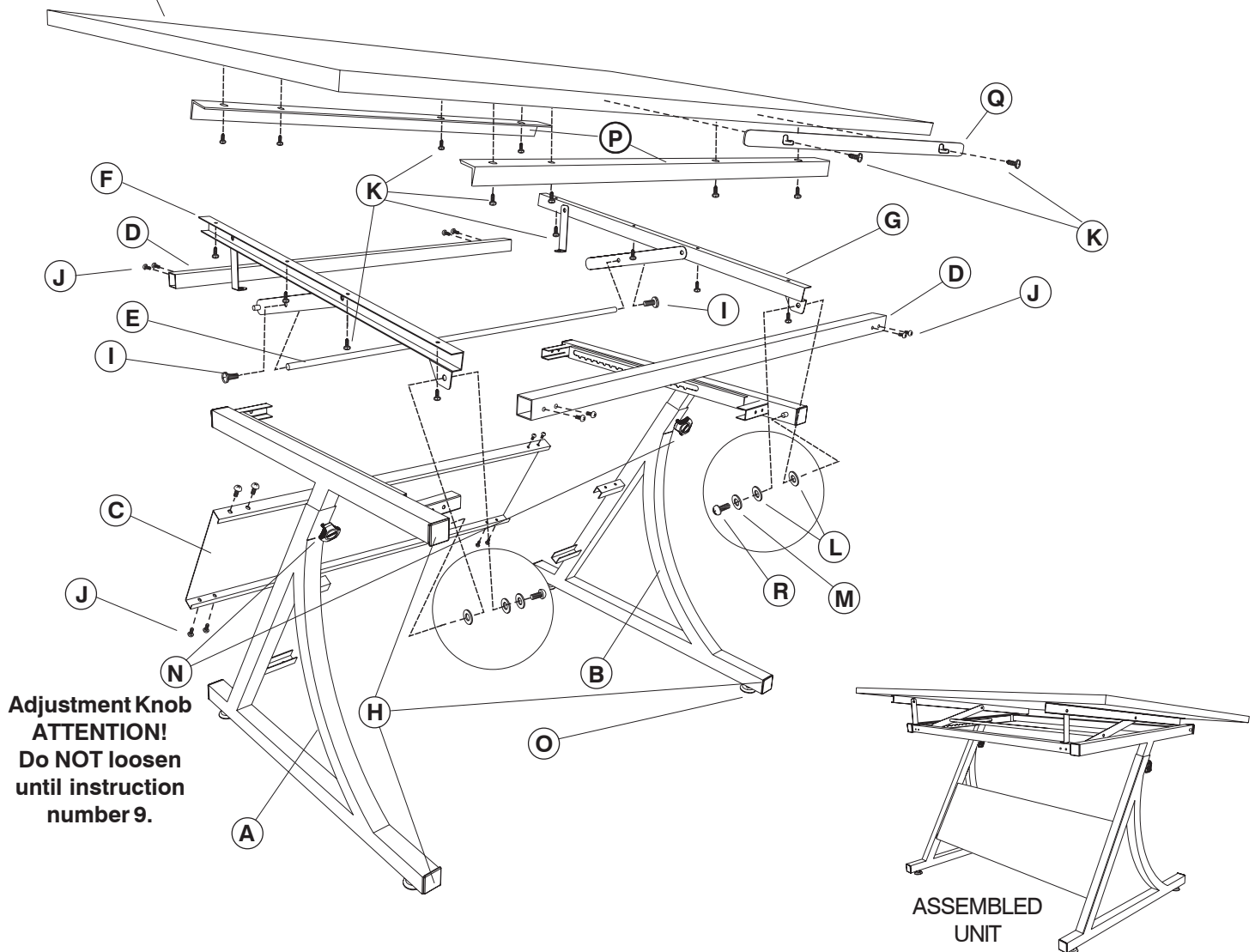

- 1** Locate the **(A)** Left Frame Assembly (the short channels will be on the right side of the frame), and the **(B)** Right Frame Assembly (the short channels will be on the left side of the frame).

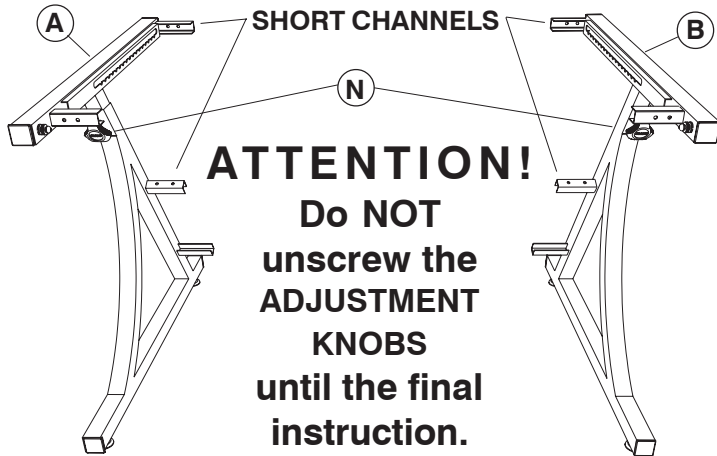

- 2** Place the **(A)** Left Frame Assembly on a protected surface with the short channels upward. Insert the **(H)** Tube Plugs if they are not already installed on the tube ends. Insert the **(O)** Levelers. Repeat with the **(B)** Right Frame Assembly.

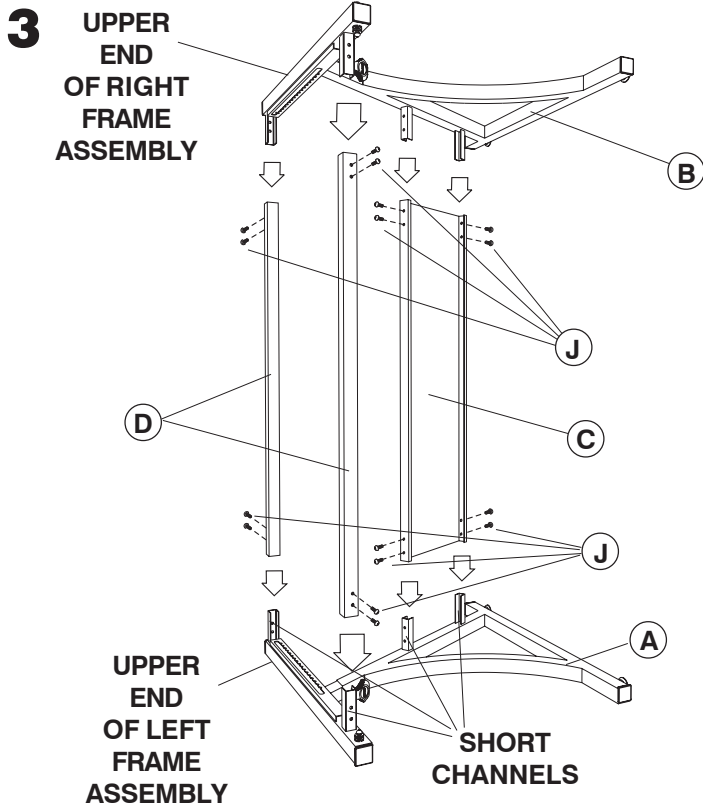
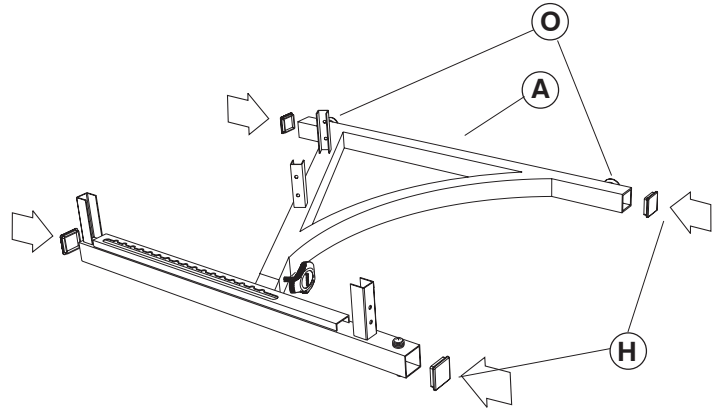

Insert the **(D)** Horizontal Tubes onto each of the short channels along the upper end of the Left Frame Assembly. Attach using two **(J)** Long Pan Head Machine Screws for each tube. Insert one end of the **(C)** Back Panel onto the two lower short channels and attach using four **(J)** Long Pan Head Machine Screws.

With the help of an assistant, carefully lift the **(B)** Right Frame Assembly up and insert the short channels into the open ends of the tube and back panel. Loosely fasten using eight **(J)** Long Pan Head Machine Screws.

Carefully turn the assembled base upright.

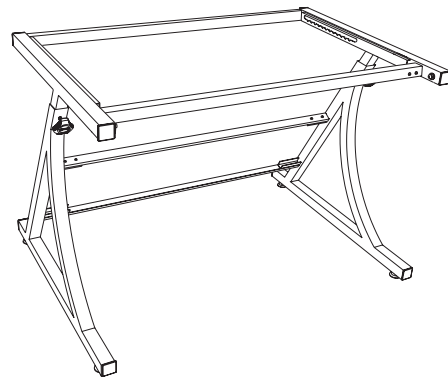

- 4** Place one **(L)** Nylon Spacer on the pin. Insert the **(G)** Support Channel onto the pin. Place one **(L)** Nylon Spacer and one **(M)** Washer on the pin and fasten securely using one **(R)** Short Pan Head Machine Screw. Repeat for the other support channel and frame.

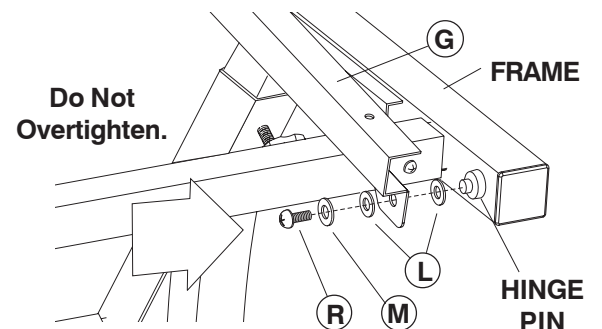

- 5** Raise the **(G)** Right Support Channel and insert the channel pin into the notched channel in the frame. Repeat this procedure for the **(F)** Left Support Channel.

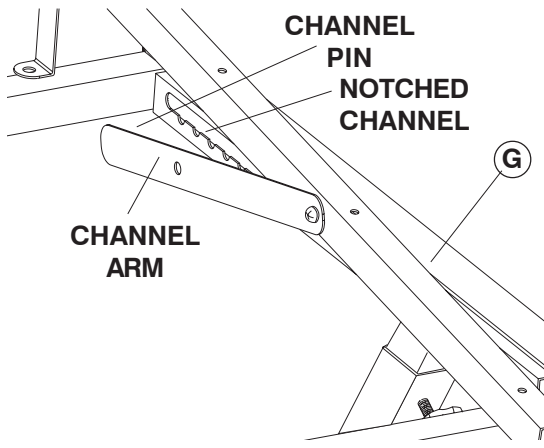

- 6** Attach the **(E)** Lift Bar to each channel arm through the counter-sunk holes using one **(I)** Large Flat Head Machine Screw at each end.

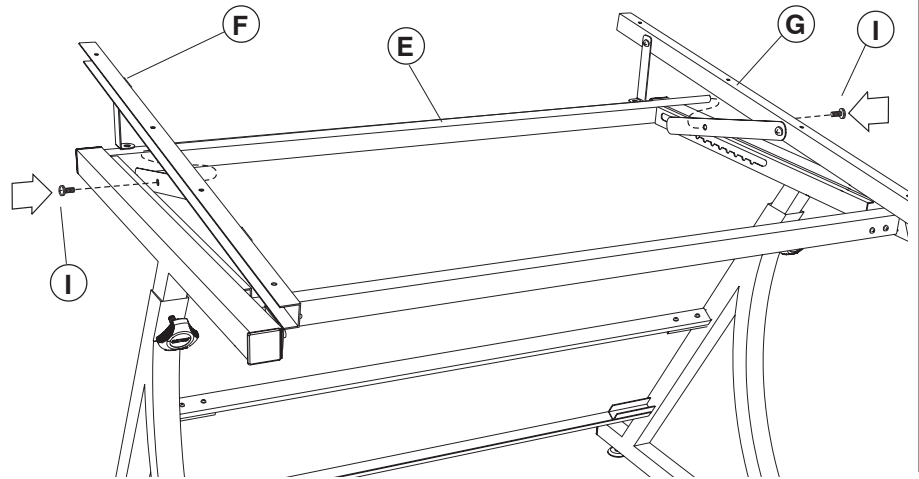

- 7** Prepare the Drawing Board. Carefully open the Drawing Board carton. Keep the Drawing Board in the carton. Two people are required to lift the assembled base onto the **(S)** or **(T)** Drawing Board. Position the **(F)** and **(G)** support channel assemblies located on the base onto the drawing board. Carefully center the frame from side-to-side and front-to-back. Fasten the support channels to the drawing board using **(K)** Pan Head Hi-Grip Screws through each channel. Attach the **(Q)** Pencil Bar to the front edge of the drawing board using two **(K)** Pan Head Hi-Grip Screws.

NOTE: if it is too difficult to get the screws into the board, position the base and use a hammer and nail to carefully tap starter holes using the channel holes as a guide. Then, finish fastening the screws to the board.

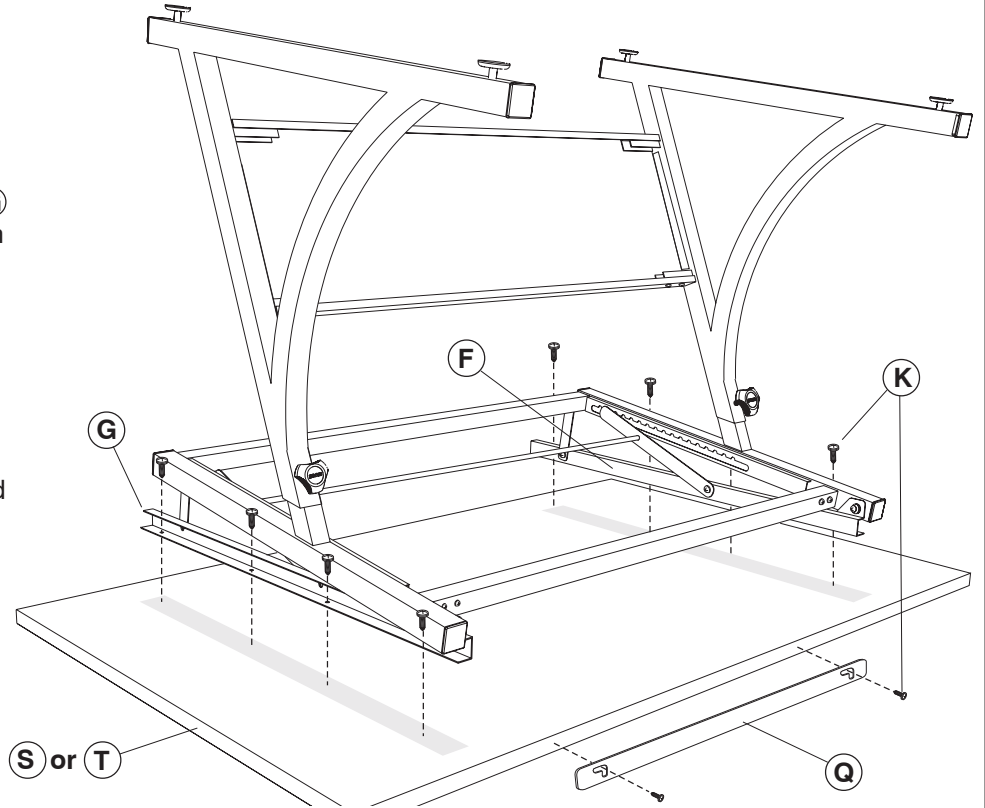

- 8** Position the **(P)** Support Bars in between the left and right support channels. The Support Bars must be placed at least 8" in from the long edges. Attach to the Drawing Board using four **(K)** Pan Head Hi-Grip Screws for each Support Bar. When the frame is securely fastened to the Drawing Board, turn the entire assembly upright.

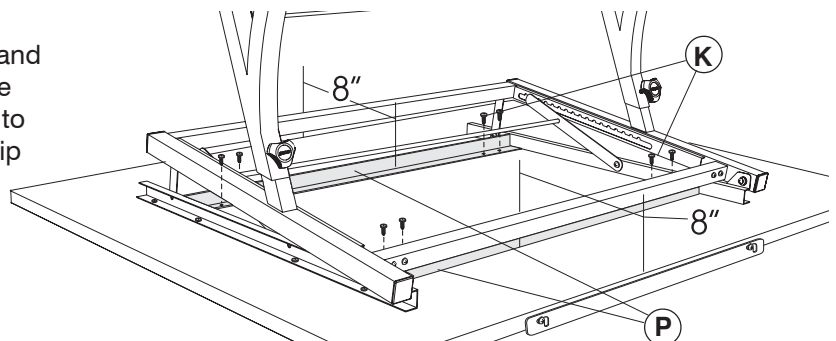

9

Lower the Drawing Board to the flat position by raising the (E) Lift Bar upward with one hand while easing the board downward with the other hand. (see inset)

Loosen the (N) Adjustment Knobs on both frames.

(ATTENTION: NEVER COMPLETELY UNSCREW THE KNOBS!)

Standing at the FRONT of the table (hinge pivot side), place your hands in the center of the drawing board approximately 30 inches apart and press down and away several times to insure proper alignment of the telescoping tubes within the end frames. When the movement is satisfactory, lock the drawing board in its lowest position by tightening the knobs.

Finish tightening the eight machine screws on the back panel, and the eight screws that attach the (D) Horizontal Tubes to the frame.

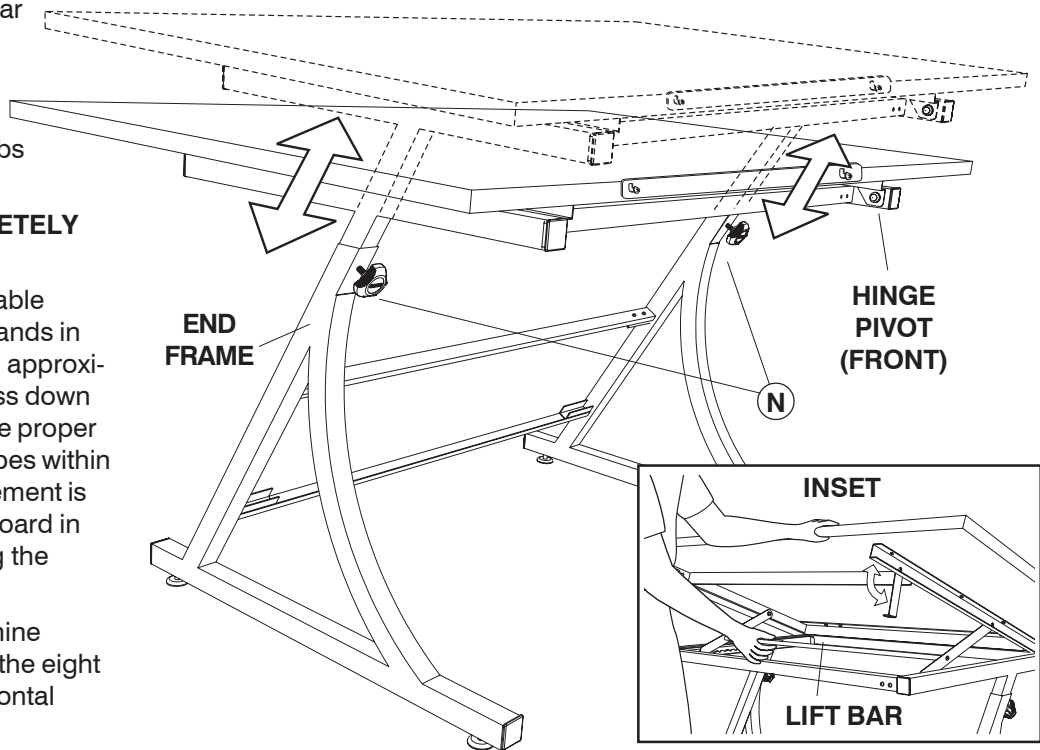

OPERATING INSTRUCTIONS

Position the table in the location where it is to be used and adjust the levelers up or down to compensate for unlevel floors.

TILT ADJUSTMENT

Automatic stops are built into the support channels for a minimum 7 degree tilt angle of the drawing board. If a 7 degree tilt is desired, simply lift the drawing board up about 5". The stops will automatically swing down into position and rest on the frame.

If a flat position is desired, each stop can be swiveled off of the frame towards the rear of the table. Be sure to hold the drawing board up so you won't injure your fingers. (see inset in step 9)

Increase the tilt angle on the drawing board by raising the Lift Bar and moving the pins at the ends of the channel arms into the notched slots on the end frames.

HEIGHT ADJUSTMENT

To elevate the entire work surface, loosen the adjustment knobs, lift drawing board by its front edge to desired height, then re-tighten the knobs (see instruction 9 inset).

