

ASSEMBLY INSTRUCTIONS
INSTRUCTIONS DE MONTAGE
INSTRUCCIONES DE ENSAMBLAJE

9442

Après™ 2 Door Cabinet
Après™ 2 porte meuble
Après™ 2 puerta armario

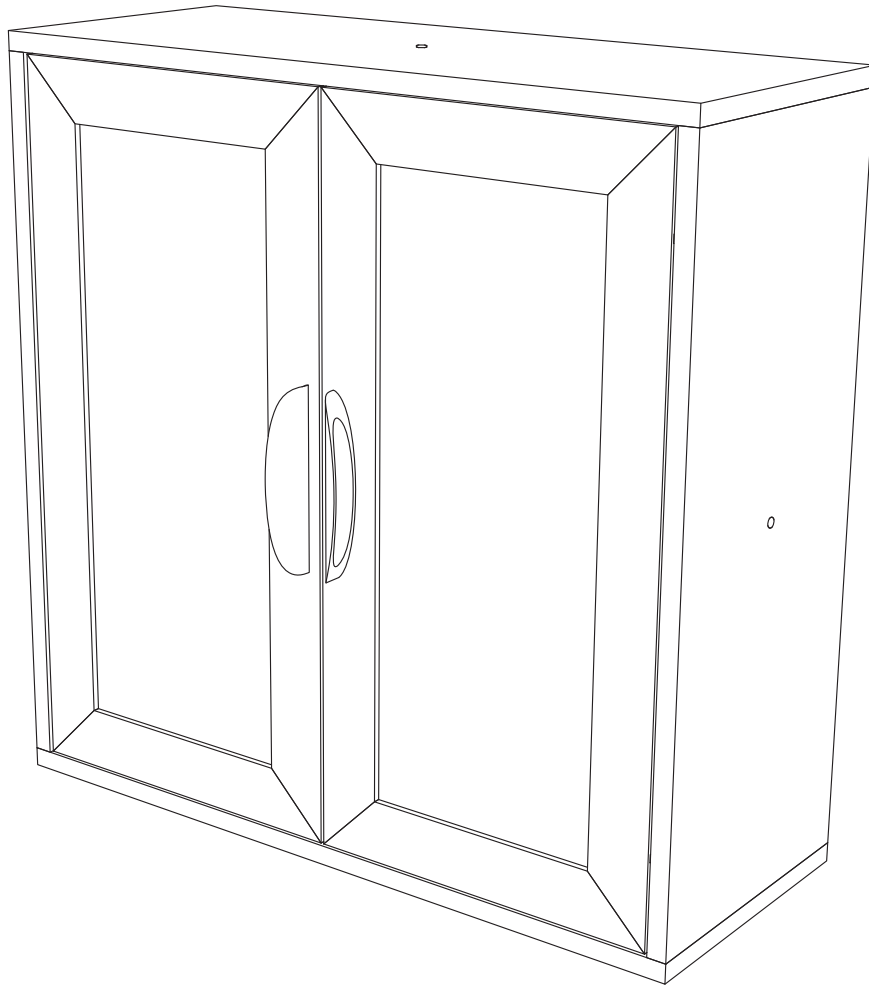

PRODUCT WARRANTY REGISTRATION is available online at: www.safcoproducts.com

• L'INSCRIPTION POUR LA GARANTIE DU PRODUIT est disponible sur l'Internet : www.safcoproducts.com

• EI REGISTRO PARA LA GARANTÍA DEL PRODUCTO está disponible en la Internet: www.safcoproducts.com

For questions or concerns, please call **1-800-664-0042**
available Monday-Friday 7:00 AM to 6:00 PM (Central Time) (English-speaking operators)

Si vous avez des questions pour poser ou les préoccupations pour exprimer, connecter **au 1-800-664-0042** de 7H00 à 18H00 (Heure centrale) (Opérateurs de langue anglaise)

Si usted tiene preguntas o preocupaciones, por favor llame **1-800-664-0042** de 7:00 AM a 6:00 PM (Hora Central) (Operadores que hablan inglés)

TOOLS REQUIRED: Flat-bladed Screwdriver; Phillips Screwdriver;
Hammer or Mallet; Tape measure













PARTS LIST

CODE	DESCRIPTION	QTY	PART NO.
(A)	Top panel	2	9442-01\$
(B)	Side panel	2	9442-02\$
(C)	Shelf	2	9440-03\$
(D)	Door	2	9442-04\$
(E)	Back panel	1	9445-09\$

§Note: When corresponding about parts, be sure to state color: Mahogany (MH), or Cherry (CY).

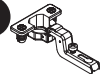
HARDWARE PACK

9442-19\$

F  Locking Cam Qty.: 8 #HFFMFC	G  Screw Post Qty.: 8 #HFFMFB	H  Shelf Peg Qty.: 8 #HSFBNZ
I  Nail Qty.: 20 #FNAIL	J  Female Connector Screw Qty.: 2 #5340-28NC	K  Male Connector Screw Qty.: 2 #5340-29NC
L  Wood Dowel Qty.: 8 #H8MMDWL	M  Wood Screw Hole Cover Qty.: 4 #9440-10\$	N  Hinge Mount Qty.: 4 #8953-14
O  Hinge Qty.: 4 #8953-16	P  Handle Qty.: 2 #8962-31	Q  Screw Qty.: 4 #1850-23
		R  Strip of 4 bumpers Qty.: 1 #9355-11nc

OUTILS REQUIS : Tournevis plat à lame ; tournevis à pointe cruciforme ; marteau ou maillet; Mètre à ruban













LISTE DES PIÈCES

CODE	DESCRIPTION	QUANTITÉ	N° DE PIÈCE
(A)	Panneau supérieur	2	9442-01\$
(B)	Panneau côté	2	9442-02\$
(C)	Étagère	2	9440-03\$
(D)	Porte	2	9442-04\$
(E)	Panneau arrière	1	9445-09\$

§ Noter: Quand correspondre au sujet de parties, soyez sûr d'affirmer la couleur: Acajou (MH) ou Cerise (CY).

Paquet matériel

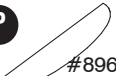
9442-19\$

F  Came Qté.: 8 #HFFMFC	G  Poteau avec la fin d'un vis Qté.: 8 #HFFMFB	H  Épingle du glissement Qté.: 8 #HSFBNZ
I  Clous Qté.: 20 #FNAIL	J  Vis pour se relier (femelle) Qté.: 2 #5340-28NC	K  Vis pour se relier (mâle) Qté.: 2 #5340-29NC
L  Piquet de bois Qté.: 8 #H8MMDWL	M  Bois pour la Couverture Trou Qté.: 4 #9440-10\$	N  Support de la charnière Qté.: 4 #8953-14
O  Charnière Qté.: 4 #8953-16	P  Poignée Qté.: 2 #8962-31	Q  Vis Qté.: 4 #1850-23
		R  Bande de 4 butoirs Qté.: 1 #9355-11NC

HERRAMIENTAS REQUERIDAS: Piso aspas destornillador; destornillador Phillips; Martillo o Mazo; Cinta métrica













LISTA DE PIEZAS

CODIGO	DESCRIPCIÓN	CANTIDAD	NO. DE PIEZA
(A)	Panel superior	2	9442-01\$
(B)	Panel lateral	2	9442-02\$
(C)	Estante	2	9440-03\$
(D)	Puerta	2	9442-04\$
(E)	Panel trasero	1	9445-09\$

§ Note: Al corresponder sobre las piezas, esté seguro declarar el color: Caoba (MH) o Cereza (CY).

Paquete material

9442-19\$

F  Leva del freno Cant.: 8 #HFFMFC	G  Poste con el tornillo-extremo Cant.: 8 #HFFMFB	H  Clavija del estante Cant.: 8 #HSFBNZ
I  Punta de Paris Cant.: 20 #FNAIL	J  Tornillo para conectar (hembra) Cant.: 2 #5340-28NC	K  Tornillo para conectar (varón) Cant.: 2 #5340-29NC
L  Clavijas de madera Cant.: 8 #H8MMDWL	M  madera para cubrir el agujero Cant.: 4 #9440-10\$	N  Apoyo de la charnela Cant.: 4 #8953-14
O  Charnela Cant.: 4 #8953-16	P  Manche Cant.: 2 #8962-31	Q  Tornillo Cant.: 4 #1850-23
		R  Tira de 4 parachoques Cant.: 1 #9355-11NC

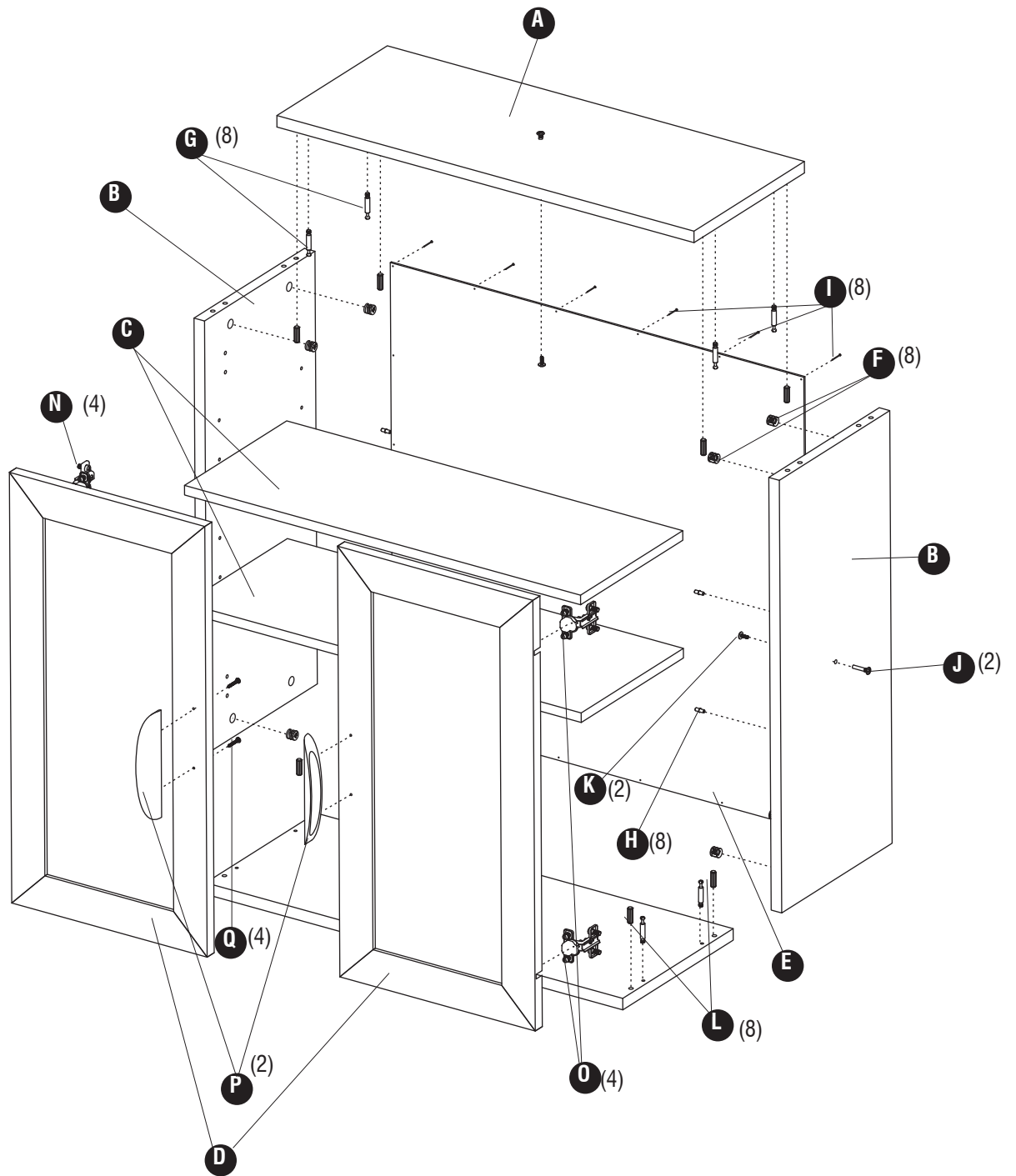

1

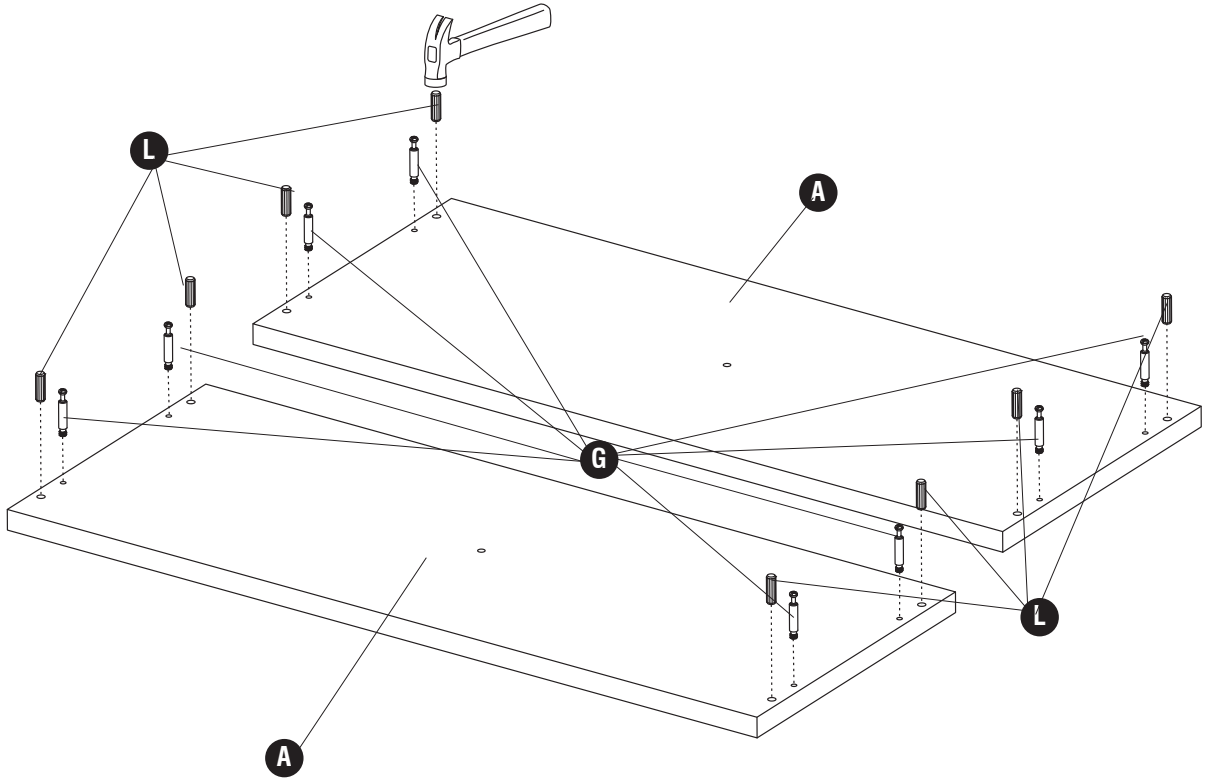
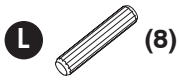

2

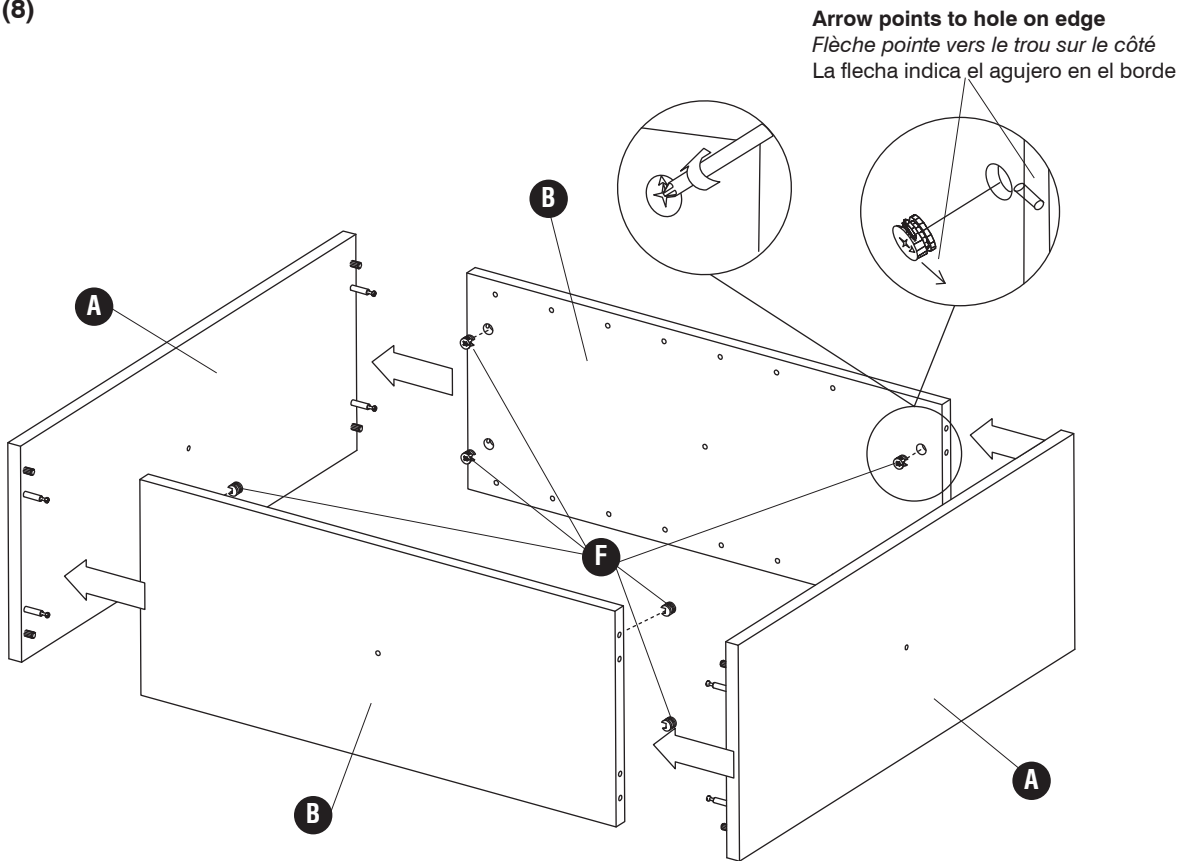

3 **I** (20)

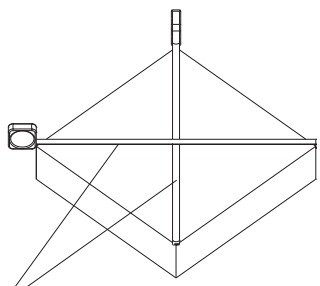
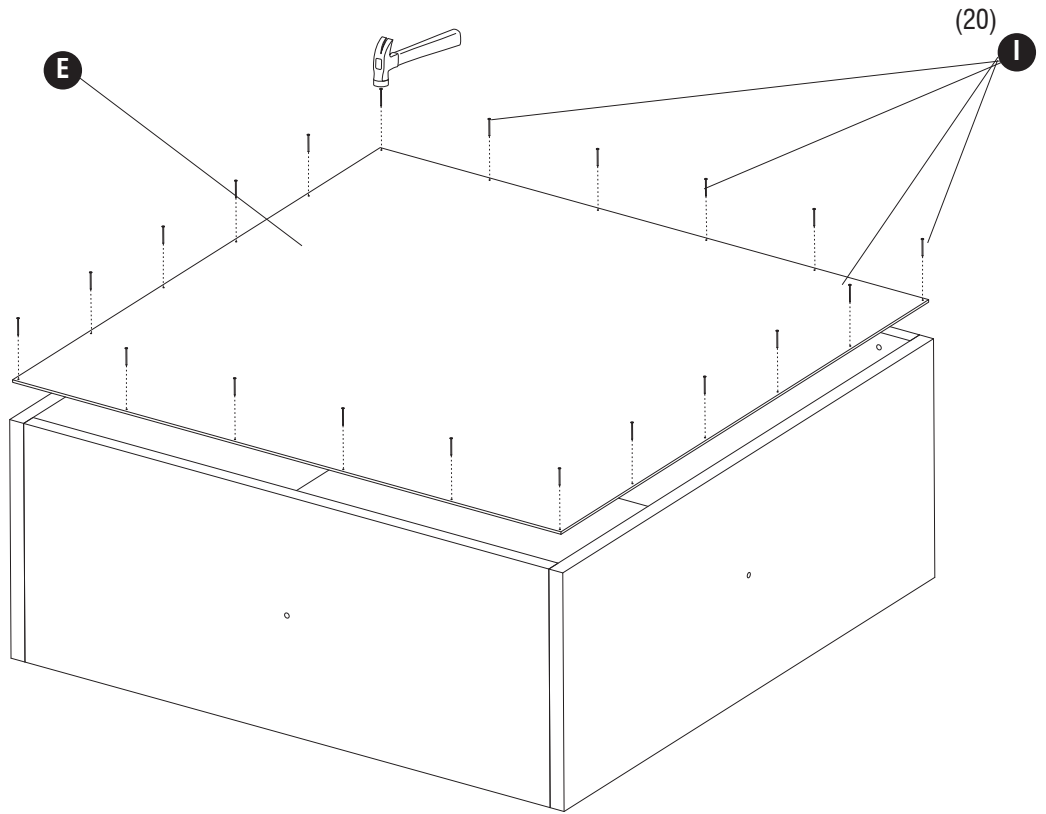

IMPORTANT: Must be equal to be square.
ATTENTION: Si l'égalité, puis l'unité est d'équerre.
IMPORTANTE: Debe ser igual al cuadrado.

4 **N** (4)

O (4)

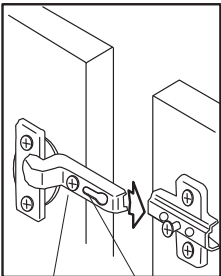

ARM
 LE BRAS
 EL BRAZO

SLOT
 LA FENTE
 LA RANURA

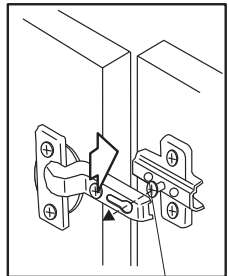

SET SCREW
 Le vis
 d'arrêt
 El tornillo de
 sujeción

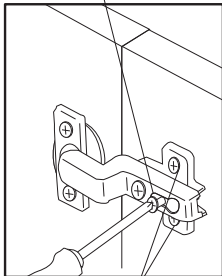

VERTICAL ADJUSTMENT
 Ajustement vertical
 Ajuste vertical

TIGHTEN SET SCREW
Serrez le vis d'arrêt
 Aprete el tornillo de
 sujeción

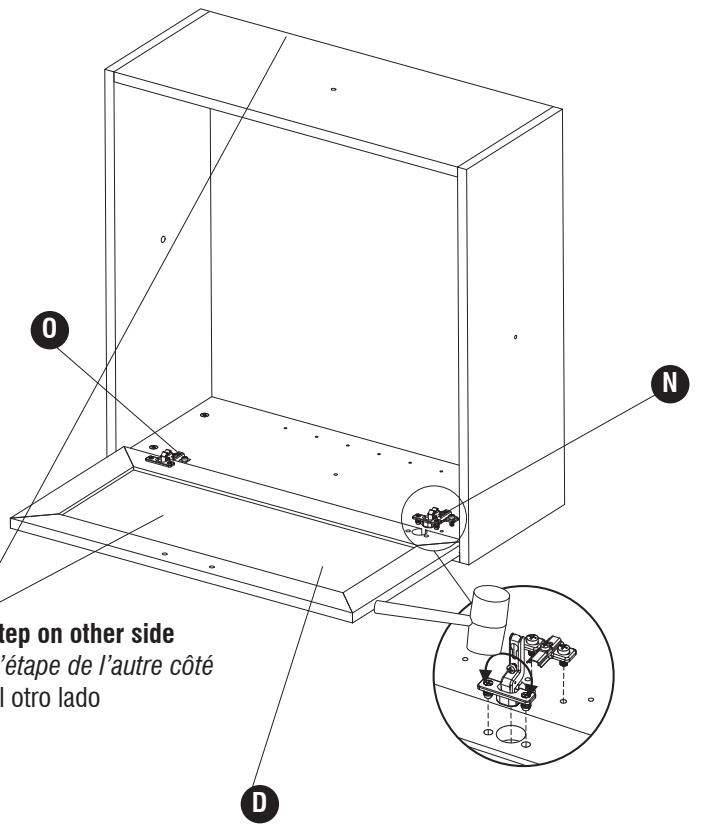

Repeat step on other side
Répétez l'étape de l'autre côté
 Repita del otro lado

5 P (2)

Q (4)

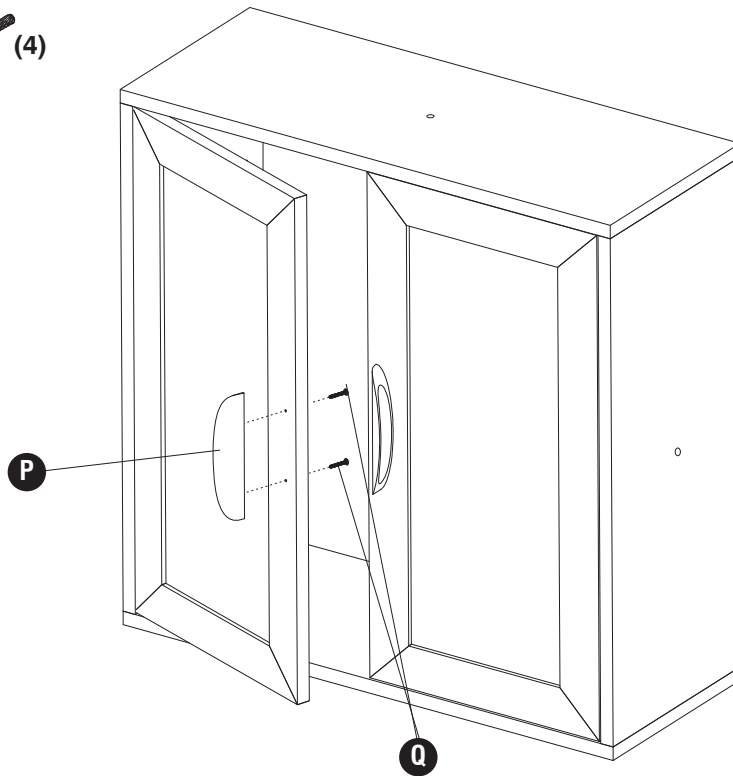

6 H (8)

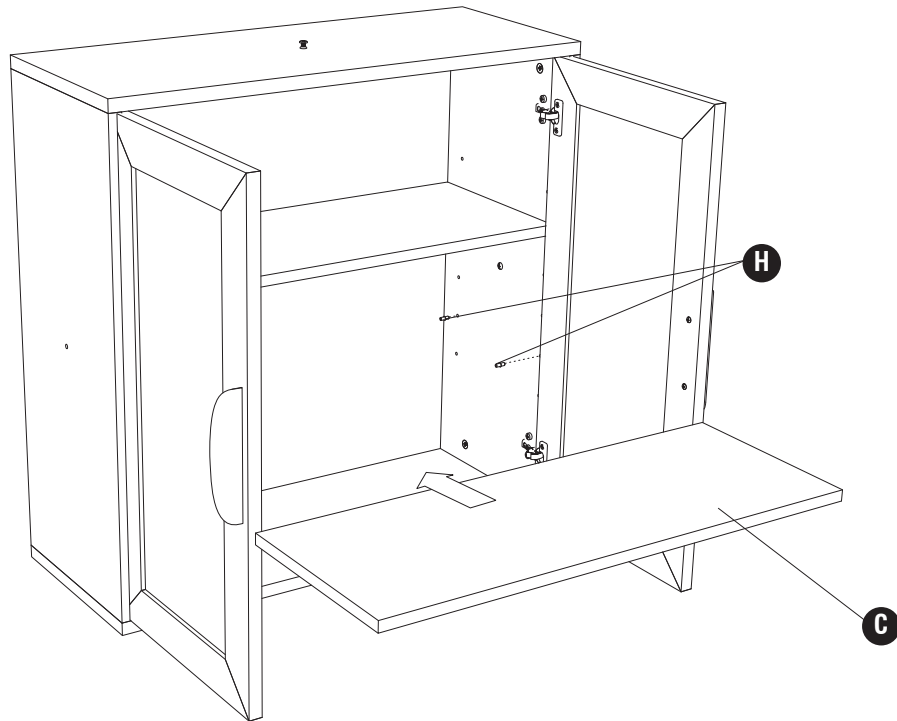

8 J (2) K (2) M (4)

Note: for connecting adjacent units only, use cap on exposed holes.

Noter: pour relier les unités adjacentes seulement, le utiliser couvercle sur exposé trou.

Note: para conectar unidades adyacentes solamente, uso madera tapon para cubrir el agujero