

MODEL AD53940

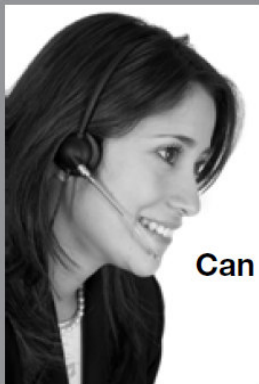

Can we help you?

THE BUSH FURNITURE

## Difference

- QUALITY
- INNOVATION
- SERVICE
- VALUE

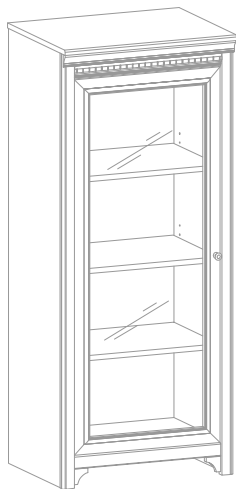

A168086

*Bush*  
FURNITURE *Signature*

**Thank you** for purchasing this Bush Furniture product. We trust that you will be completely satisfied with your product for many years to come. Bush Furniture products are backed by a 1-year warranty and crafted with today's styles in mind for the way you work. **Do not return product to store — contact us first at 1-800-950-4782.**

**Merci** d'avoir acheté ce produit Bush Furniture. Nous sommes sûr que vous serez complètement satisfait de votre meuble pendant de nombreuses années. Les produits Bush Furniture sont garantis pendant 1 an et sont conçus dans les styles actuels tout en gardant à l'esprit votre façon de travailler. **Ne renvoyez pas le produit au magasin, contactez-nous d'abord au 1-800-950-4782.**

**Gracias** por comprar este producto de Bush Furniture. Confiamos que usted estará completamente satisfecho con su mueble por muchos años. Los productos de Bush Furniture tienen 1 año de garantía y son diseñados con los estilos de hoy en mente para la manera que usted vive. **No devuelva el producto a la tienda, primero comuníquese con nosotros al 1-800-950-4782.**

*Bush*  
FURNITURE *Signature*

**1 Year**  
WARRANTY



**M - F 8:30 a.m. - 7:30 p.m. ET  
(Except Holidays)**

Bush Consumer Services  
One Mason Drive  
Jamestown, NY 14701

ConsumerService@Bushindustries.com

1-800-950-4782 USA/CANADA

1-800-950-4782 MEXICO

Se habla español

Outside USA/CANADA/MEXICO

001-716-665-2510 Ext. 5900

**1** Year  
WARRANTY

[www.bushfurniture.com/bushsignature](http://www.bushfurniture.com/bushsignature)

## IT'S AS EASY AS 1,2,3

### Assembly tips:

1. Read the instructions and become familiar with the parts.
2. Ensure this carton contains all parts, fasteners and hardware.
3. To protect floors, assemble the furniture on the carton.
4. An assistant may be helpful.
5. Use of power tools is not recommended.

### Conseils d'assemblage:

1. Lisez les instructions et familiarisez-vous avec les pièces.
2. Assurez-vous que le carton contient toutes les pièces, toutes les pièces de fixation et toute la quincaillerie.
3. Pour protéger vos sols, assemblez le meuble sur le carton.
4. Il peut être utile de vous faire aider.
5. L'utilisation d'outils électriques n'est pas recommandée.

### Consejos de Ensamblaje:

1. Lea las instrucciones y familiarícese con las partes.
2. Asegúrese de que esta caja contenga todas las piezas, los sujetadores y el equipo.
3. Para proteger el piso, ensamble el mueble en el carton.
4. Un asistente puede serle útil.
5. El uso de herramientas eléctricas no se recomienda.

## CONSUMER SERVICE YOU CAN DEPEND ON

Questions? Operators are standing by at our TOLL-FREE help line to assist you with assembly; and, if necessary, to quickly replace damaged/missing parts. Assistance is available 5 days a week. Simply have your store receipt, instruction manual, and part number/description ready when you call our TOLL-FREE help line. It's that easy.

### UN SERVICE CLIENTELE SUR LEQUEL VOUS POUVEZ COMPTER

Des questions? Des opérateurs sont prêts sur notre ligne d'assistance GRATUITE pour vous aider à l'assemblage et, si nécessaire, remplacer rapidement les pièces endommagées/manquantes. L'assistance est disponible 5 jours par semaine. Ayez simplement votre reçu de magasin, votre manuel d'instruction et le numéro de pièces/description à votre disposition lorsque vous appelez notre ligne d'assistance GRATUITE. C'est aussi simple que ça.

### SERVICIO AL CONSUMIDOR CON EL QUE PUEDE CONTAR

¿Preguntas? Los operadores están listos para ayudarlo con el ensamblaje a través de una línea de ayuda GRATUITA, y en caso de ser necesario, reemplazar de inmediato las piezas dañadas o faltantes. La asistencia está disponible los 5 días de la semana. Solamente tenga listos su recibo de compra, manual de indicaciones y número/descripción de la pieza al momento de llamarnos a la línea de ayuda

# IMPORTANT SAFETY INFORMATION



## WARNING

Do not load unit without properly attaching back panel. Doing so could cause instability, product collapse, and/or serious injury.

---

No cargue esta unidad sin el panel de atrás. Hacerlo puede causar inestabilidad, que el producto se derrumbe, y/o heridas (golpes) serias.

---

Ne pas charger le produit sans attacher correctement le panneau arrière. Faire ainsi peut causer l'instabilité ou l'effondrement du produit et peut vous causer des endommagements sérieux.



## WARNING

Do not move unit when loaded. Doing so could cause instability, product collapse, tip over, and/or serious injury.

---

No mueva la unidad cuando esté cargada. Hacerlo puede causar inestabilidad, que el producto se derrumbe, que se la caiga encima y/o heridas (golpes) serias.

---

Ne pas déplacer l'unité lorsqu'elle est chargée. Faire ainsi peut causer l'instabilité, l'effondrement ou le renversement du meuble et/ou des endommagements sérieux.

# IMPORTANT SAFETY INFORMATION



## CAUTION



Risk of breaking glass. Handle glass carefully during assembly. Use eye and hand protection. Improper handling can result in cuts or lacerations.

Riesgo de romper el vidrio. Maneje el vidrio con cuidado al ensamblar esta unidad. Use protección para sus ojos y sus manos. El manejo inapropiado del vidrio puede causar cortes o laceraciones.

Risque de bris de verre. Faites attention lors de la manipulation du verre pendant l'assemblage. Utilisez des protections pour les yeux et les mains. Une mauvaise manipulation peut provoquer des coupures ou des lacerations.



## WARNING

This product is designed and intended for use with audio components and video playing equipment only. Improper loading with television or other heavy equipment could cause instability, tip over, and/or serious injury.

Este producto ha sido diseñado para ser usado con componentes de audio y reproducción de video exclusivamente. El uso inapropiado con un televisor u otro equipo pesado puede causar la inestabilidad del producto, que se derrumbe, pudiendo causar serias heridas.

Ce produit est conçu pour et destiné à être utilisé uniquement avec des composants de lecture audio et vidéo. Le chargement inapproprié d'un téléviseur ou d'un autre équipement lourd pourrait provoquer l'instabilité, le renversement du meuble et/ou des blessures graves.

# EXPLODED VIEW

A [1] W158783	I [1] W158791
B [1] W158784	J [1] W158792
C [1] W158785	K [2] W158793
D [1] W158786	L [1] W158794
E [1] W158787	M [1] S158795
F [1] W158788	N [1] S158796
G [1] W158789	O [1] W158797
H [1] W158790	

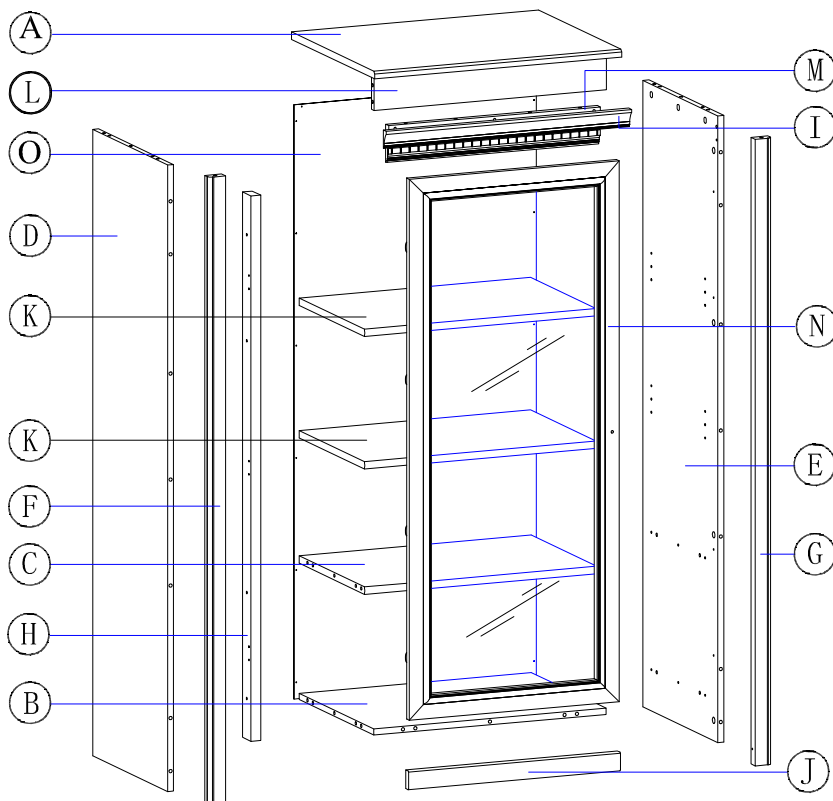
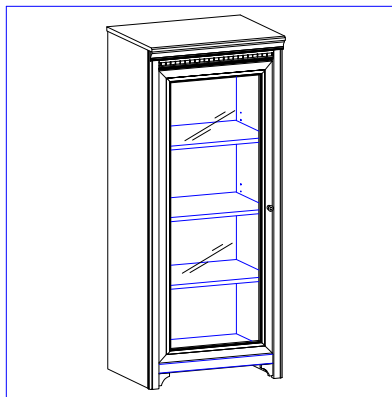

# FASTENERS

Fastners are shown in actual size.

Los fijadores son demostrados en su tamaño actual.

Les attaches sont montrées dans l'échelle grandeur.

H159916

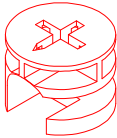

Quantity  
**35**

H159917

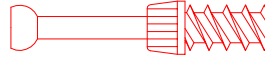

Quantity  
**35**

H156826



#3 x 3/4"

Quantity  
**43**

H156823

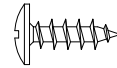

#8 x 1/2"

Quantity  
**2**

H156874

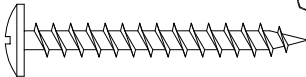

#10 x 1-1/2"

Quantity  
**6**

H153244

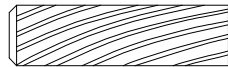

8 x 30mm

Quantity  
**30**

H168085

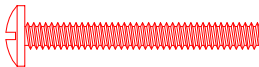

M4 x 30mm

Quantity  
**1**

H156825



#6 x 1/2"

Quantity  
**1**

H153242

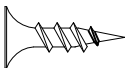

#8 x 5/8"

Quantity  
**12**

H156851

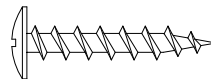

#10 x 1"

Quantity  
**3**

# HARDWARE

H153542

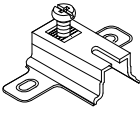

Quantity  
**3**

H153543

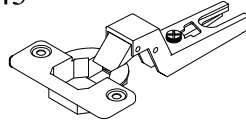

Quantity  
**3**

H158707

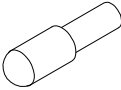

Quantity  
**8**

H156829



Quantity  
**4**

H156832

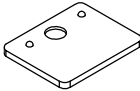

Quantity  
**1**

H158802



Quantity  
**9**

H146711

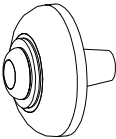

Quantity  
**1**

H146712



Quantity  
**1**

H158800

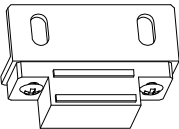

Quantity  
**1**

H158801

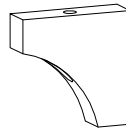

Quantity  
**2**

**Common assembly techniques.**  
**Técnica común de ensamblaje.**  
**Techniques communes d'assemblage.**

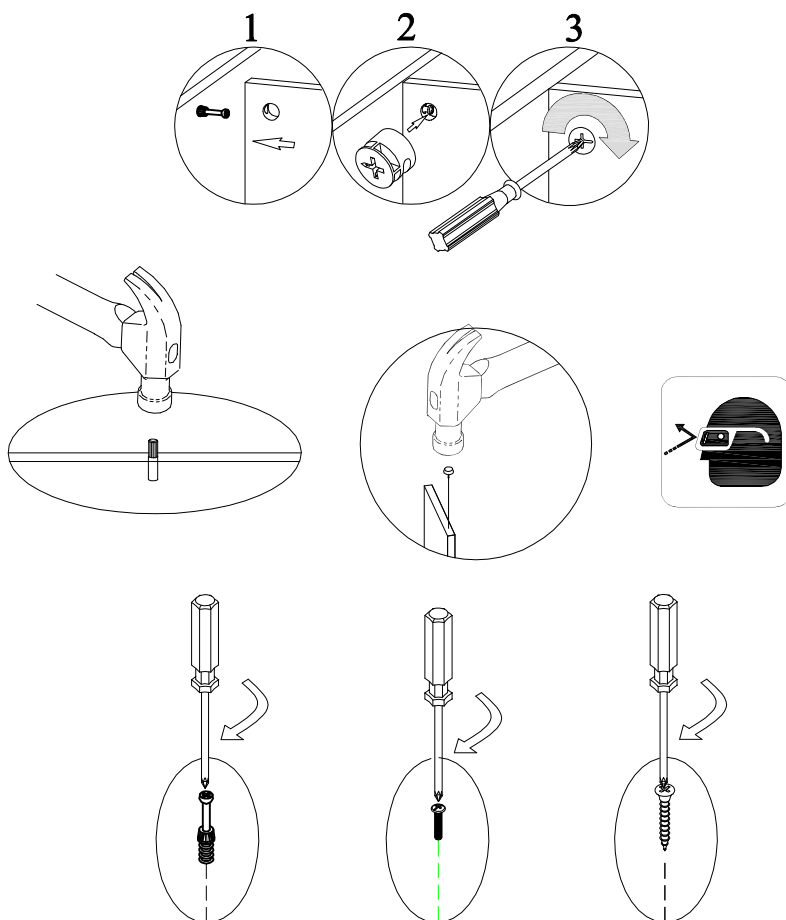

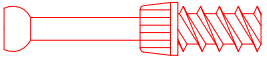
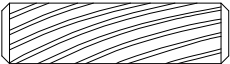

# STEP 1

H159917  [ 7 ]    H153244  [ 2 ]

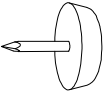
H156829  [ 1 ]

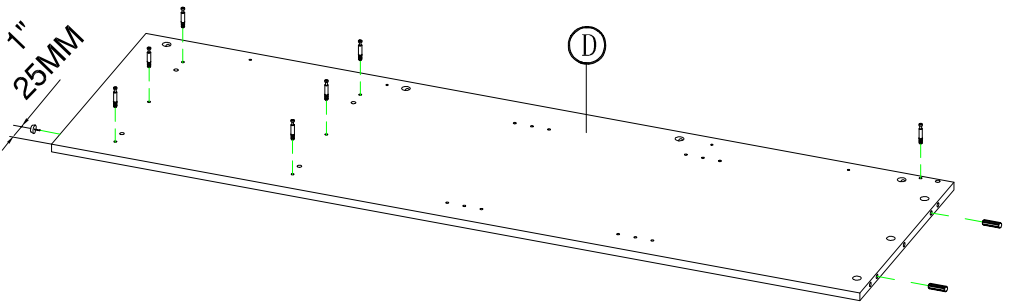

# STEP 2

H153244



[ 14 ]

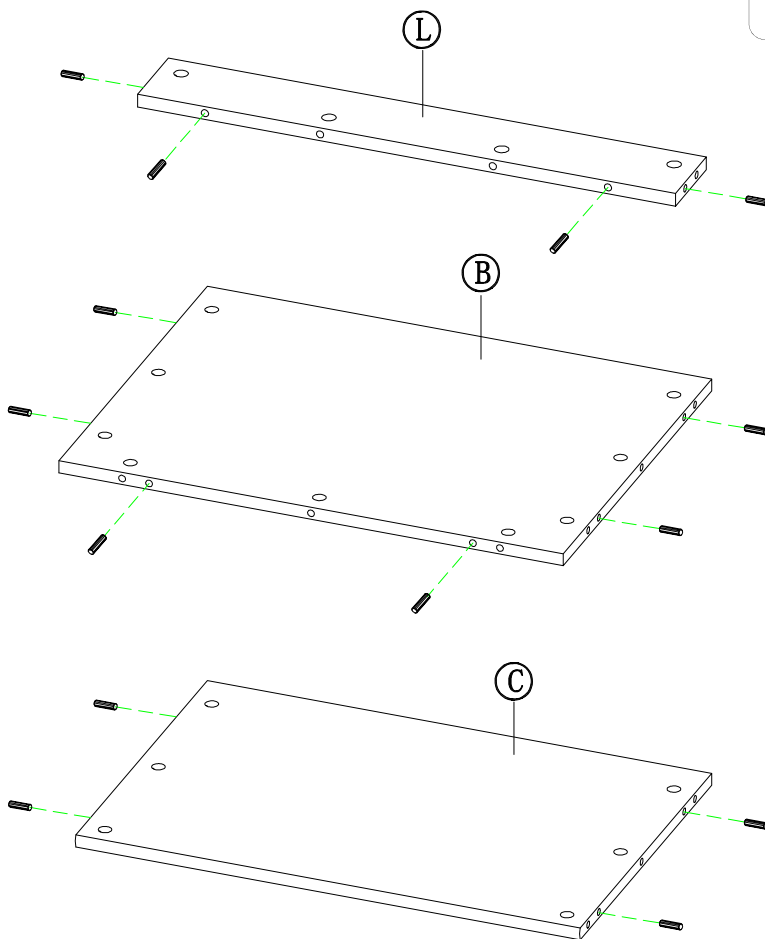

1 - 800 - 950 - 4782

A168086

## STEP 3

H159916

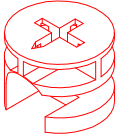

[ 7 ]

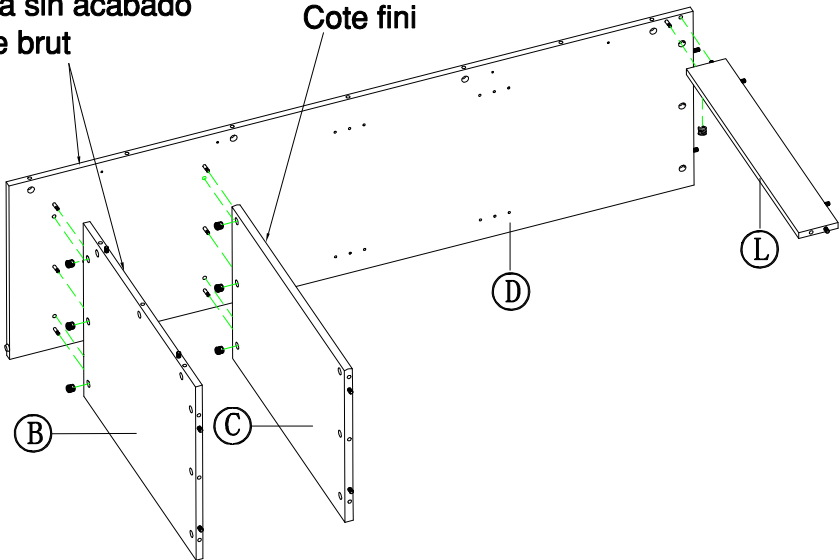

Raw edge  
Orilla sin acabado  
Cote brut

Finished edge  
Borde terminado  
Cote fini

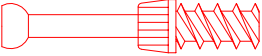

An assistant is required.  
Es necesario un ayudante.  
Un assistant est nécessaire.

# STEP 4

H159917  [ 7 ]    H153244  [ 2 ]

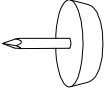
H156829  [ 1 ]

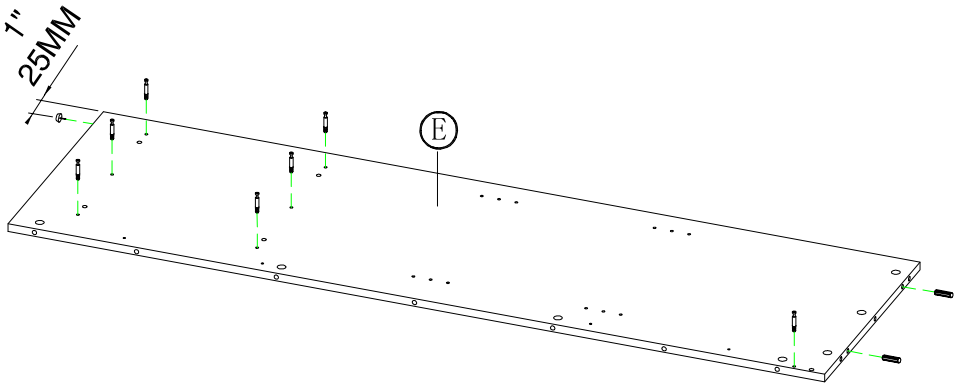

# STEP 5

H159916

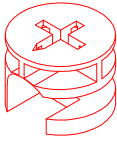

[ 7 ]

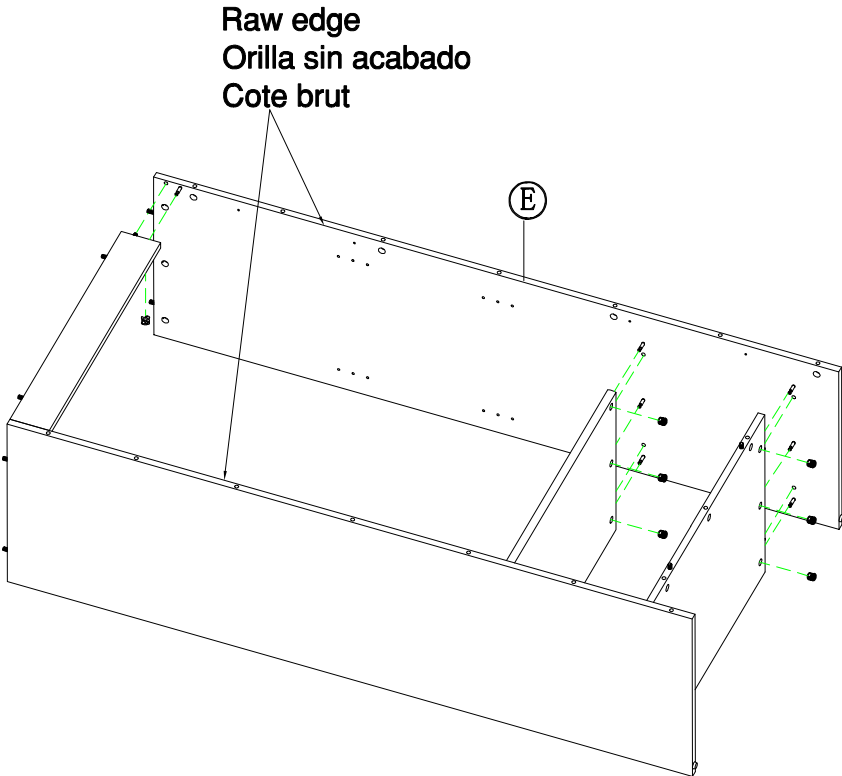



An assistant is required.  
Es necesario un ayudante.  
Un assistant est nécessaire

7 1 - 800 - 950 - 4782

A168086

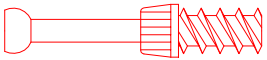
# STEP 6

H159917  [ 8 ] H153244  [ 8 ]

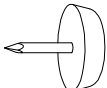
H156829  [ 2 ]

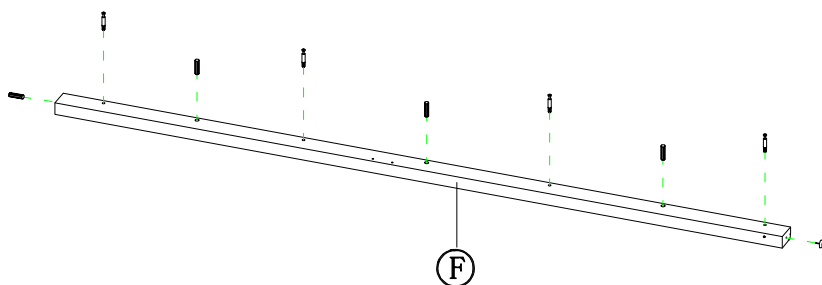
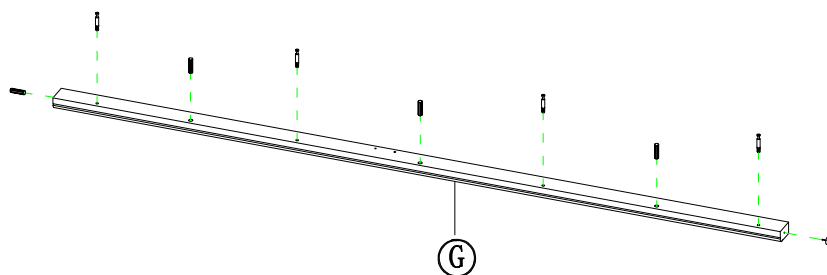

# STEP 7

H159916

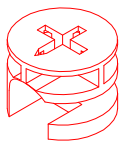

[ 8 ]

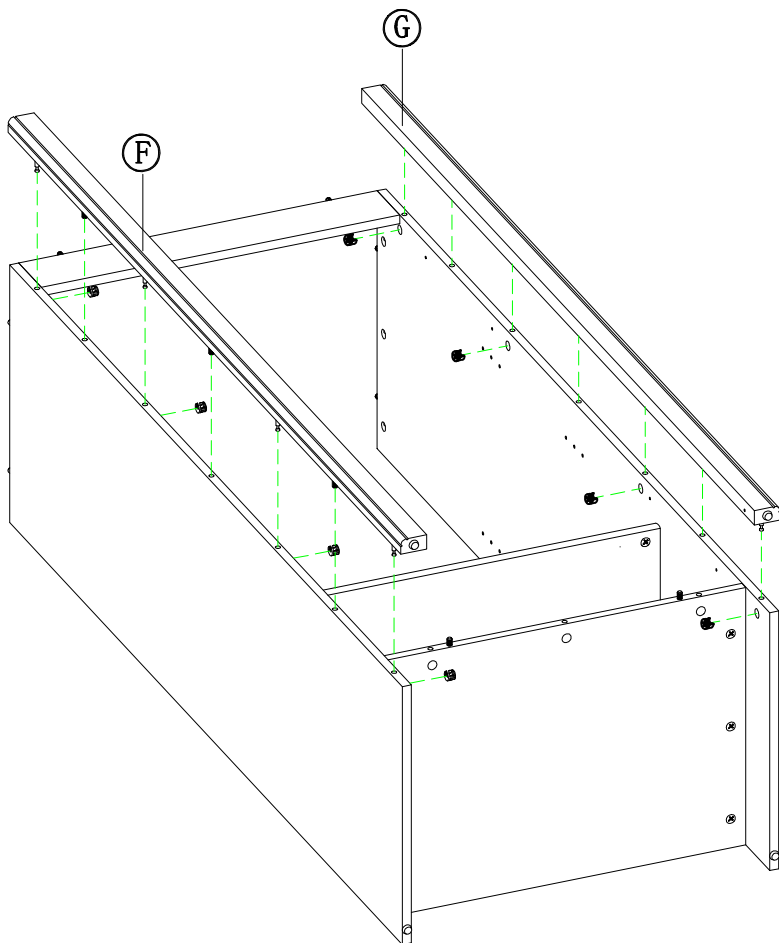

1 - 800 - 950 - 4782

A168086

# STEP 8

H159917  [ 10 ]

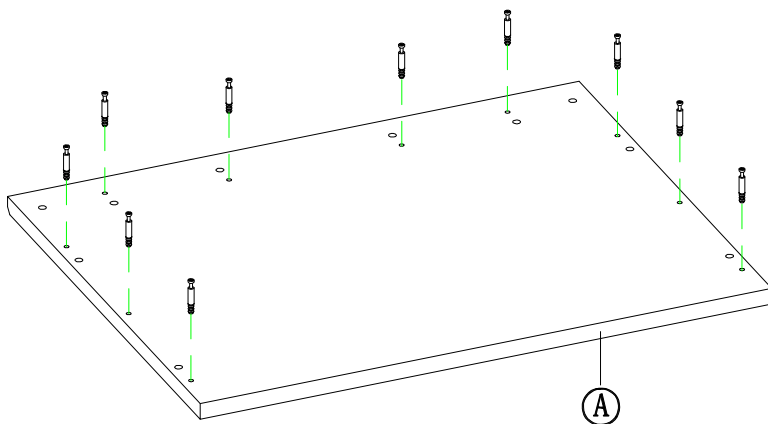

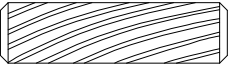
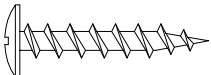

# STEP 9

H153244  [ 2 ] H156851  [ 3 ]

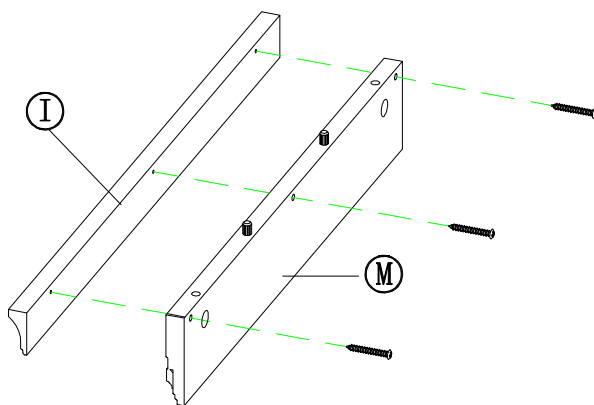
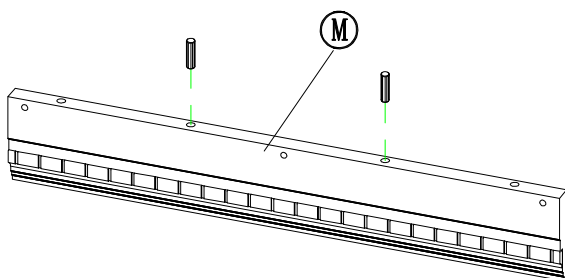

# STEP 10

H159916

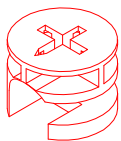

[ 2 ]

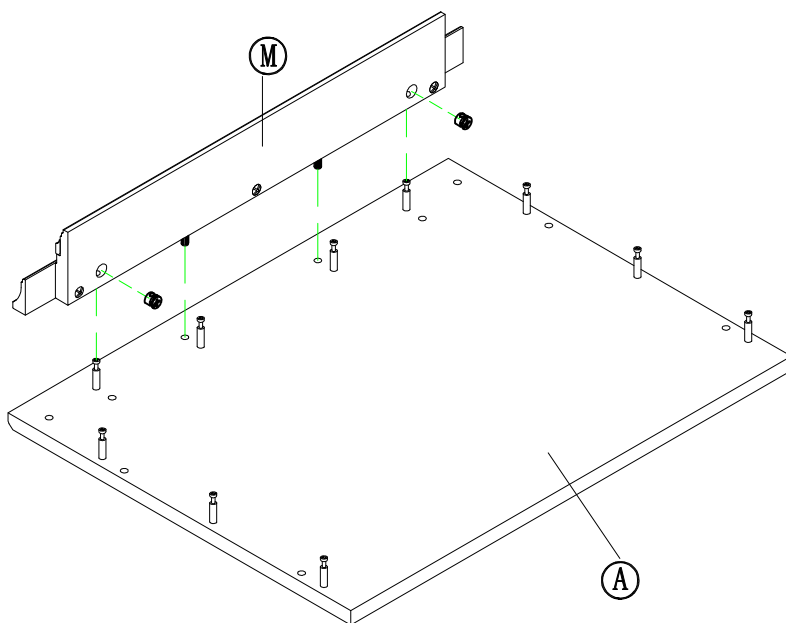

# STEP 11

H159916

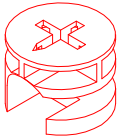

[ 8 ] H158802



[ 6 ]

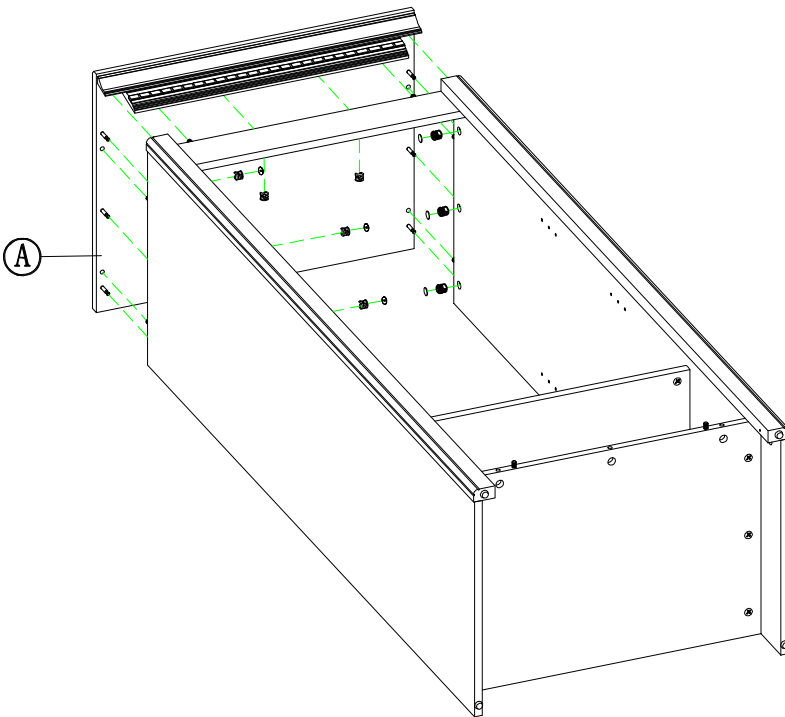

An assistant is required.  
Es necesario un ayudante.  
Un assistant est nécessaire.

1 - 800 - 950 - 4782

A168086

# STEP 12

H159917  [3]

H159916

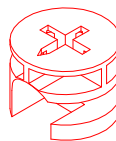

[3]

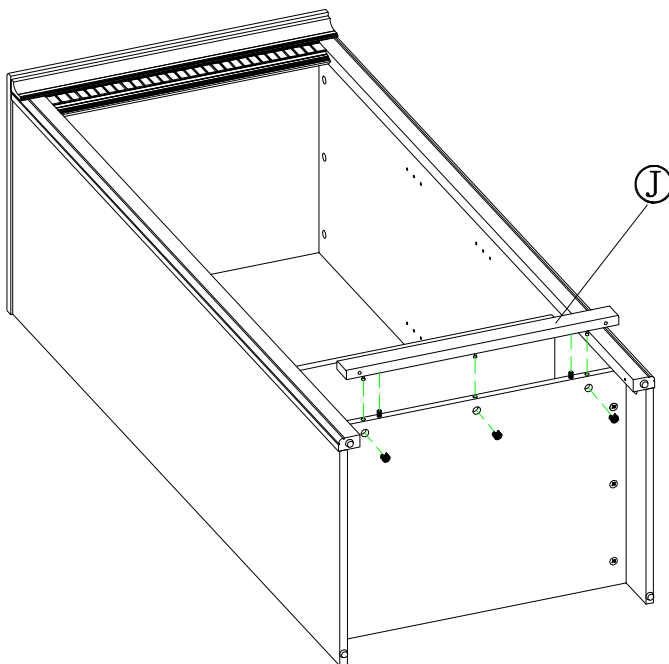
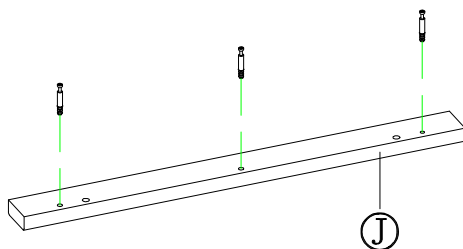

1 - 800 - 950 - 4782

A168086

# STEP 13

H153244



[ 2 ]

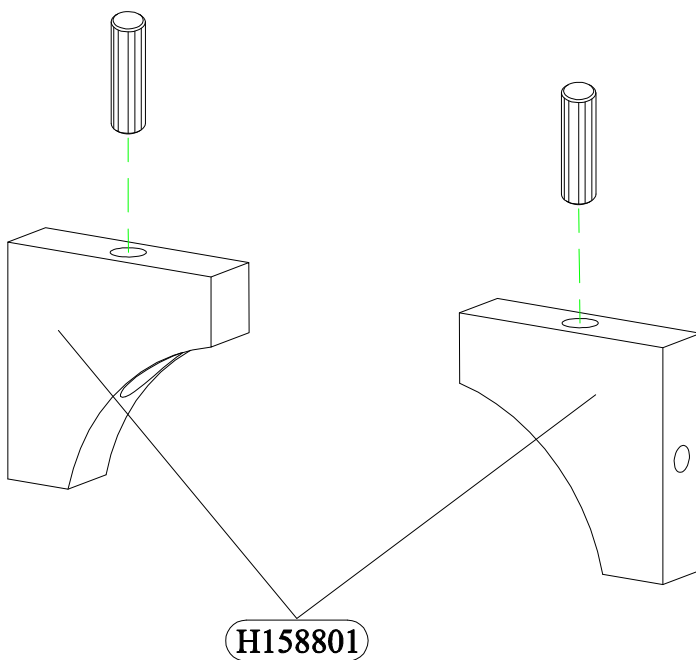

# STEP 14

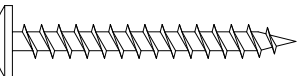
H156874  [ 2 ]

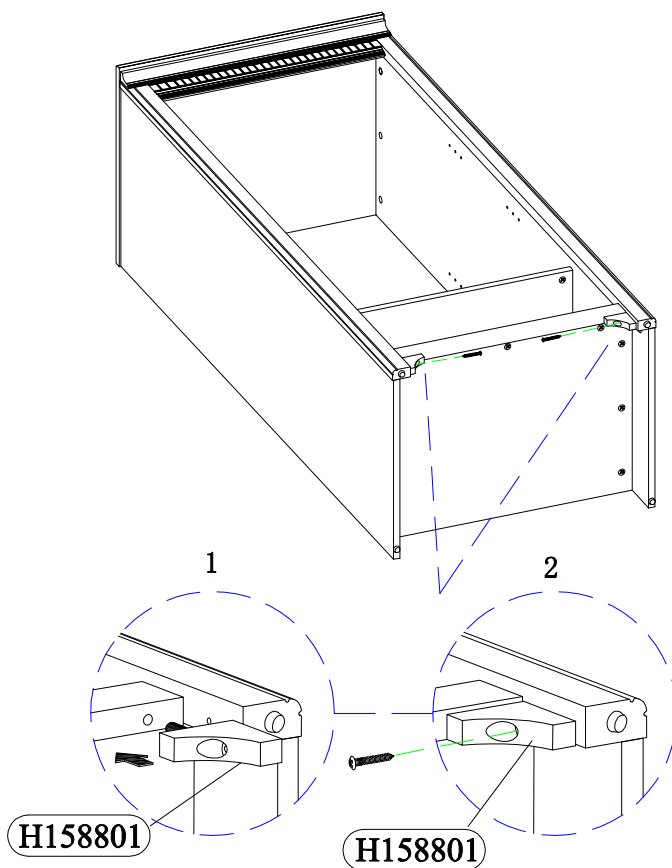

# STEP 15

H153242

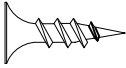

[ 6 ]

H153542

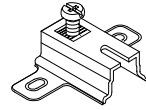

[ 3 ]

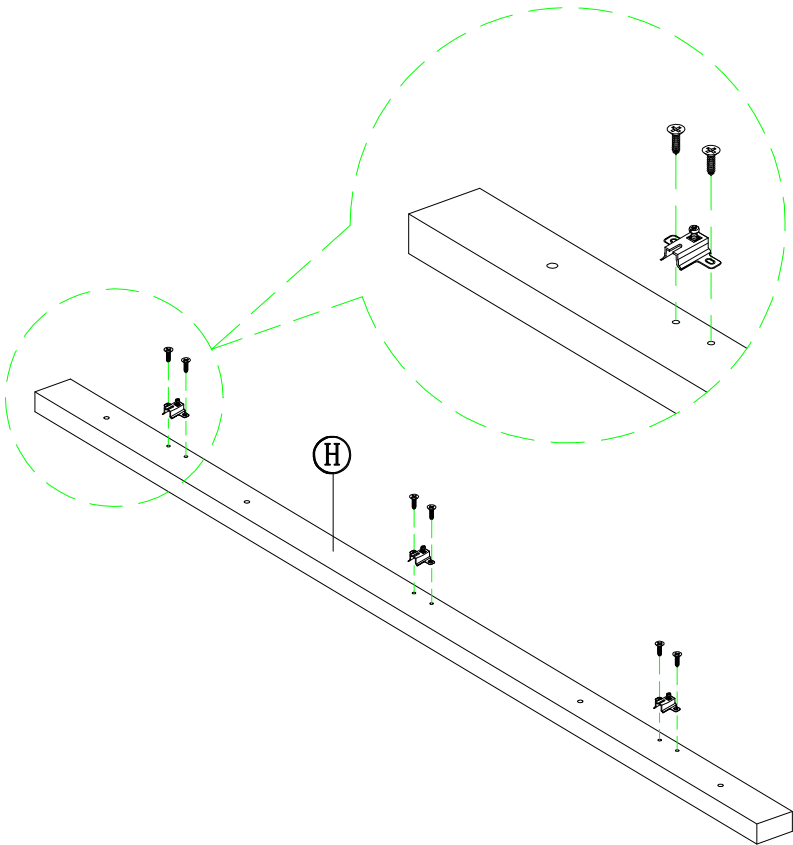

# STEP 16

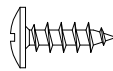
H156874  [ 4 ] H156823  [ 2 ]

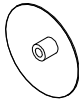
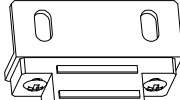
H158802  [ 3 ] H158800  [ 1 ]

Left mounting option  
Opción para Mintura izquierda  
Option gauche de montage

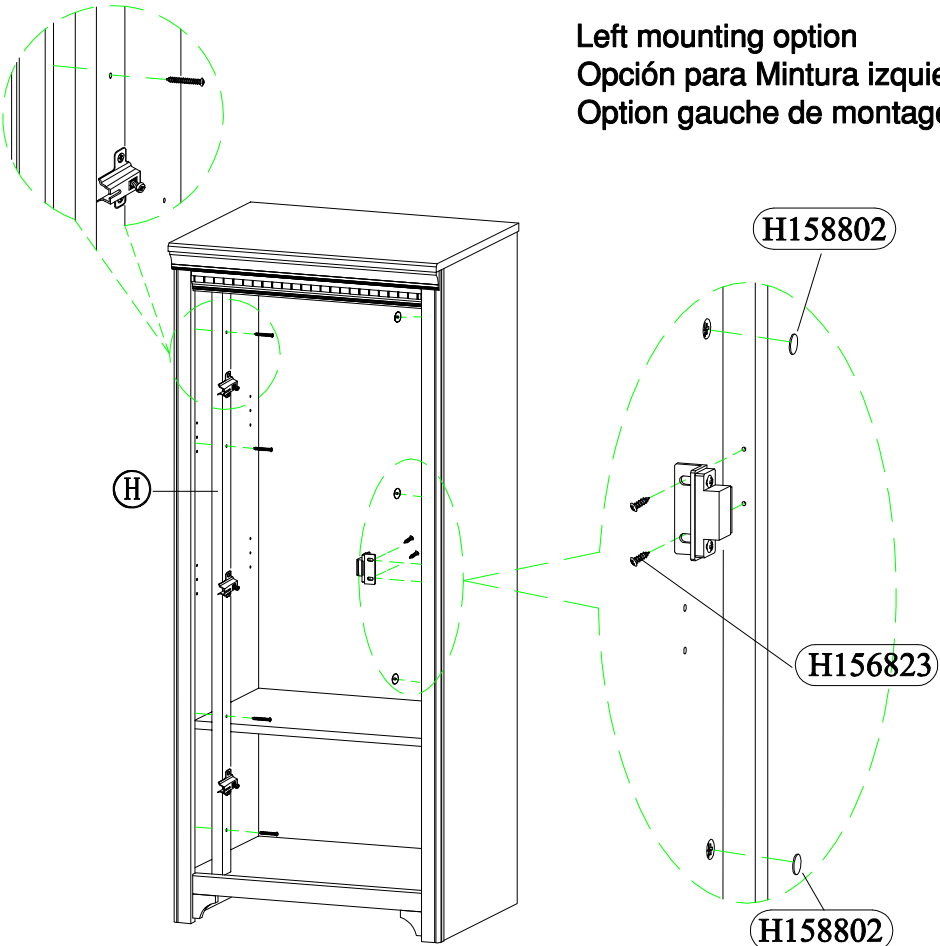



**1 - 800 - 950 - 4782**

**A168086**

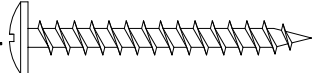
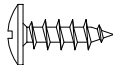

# STEP 17

H156874  [ 4 ] H156823  [ 2 ]

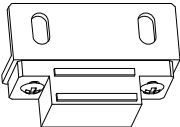
H158802  [ 3 ] H158800  [ 1 ]

Right mounting option  
Opción para Montura derecha  
Option droite de montage

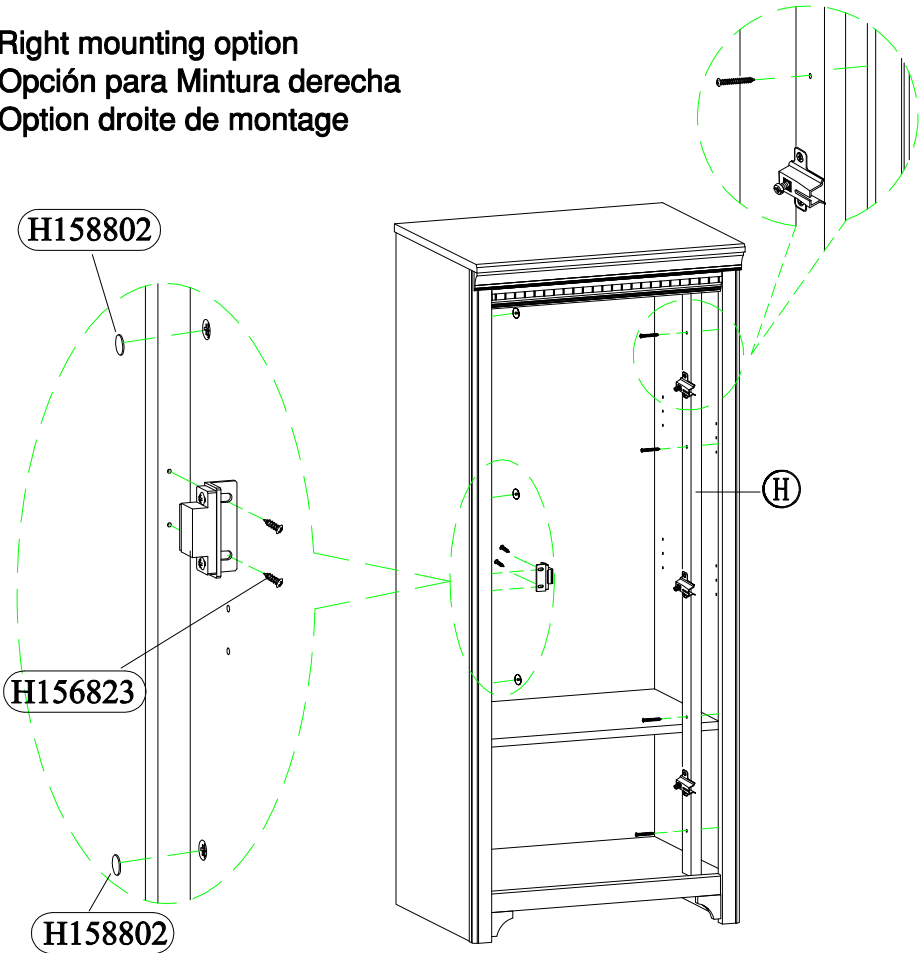

## STEP 18

H156826  [ 43 ]

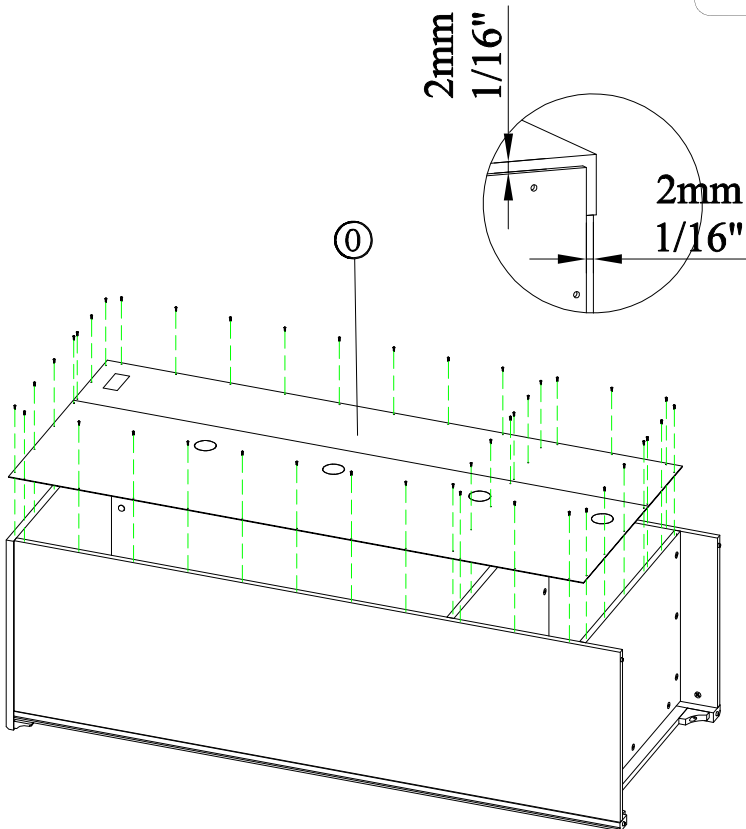





An assistant is required.  
Es necesario un ayudante.  
Un assistant est nécessaire.

 1 - 800 - 950 - 4782

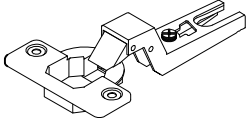
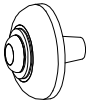
A168086

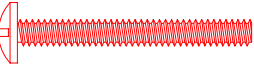
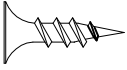
# STEP 19

- |         |                                                                                   |       |         |                                                                                    |       |
|---------|-----------------------------------------------------------------------------------|-------|---------|------------------------------------------------------------------------------------|-------|
| H153543 |  | [ 3 ] | H146711 |   | [ 1 ] |
| H156832 |  | [ 1 ] | H146712 |   | [ 1 ] |
| H168085 |  | [ 1 ] | H153242 |   | [ 6 ] |
| H156825 |  | [ 1 ] |         |  |       |

Left mounting option  
 Opción para Mintura izquierda  
 Option gauche de montage

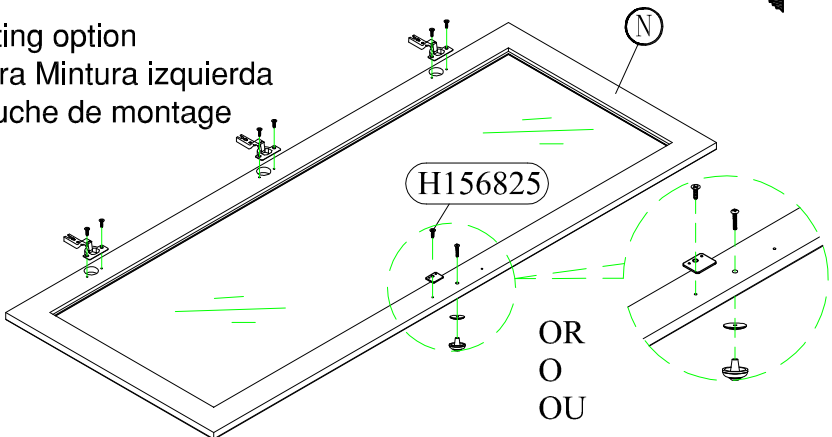

Right mounting option  
 Opción para Mintura derecha  
 Option droite de montage

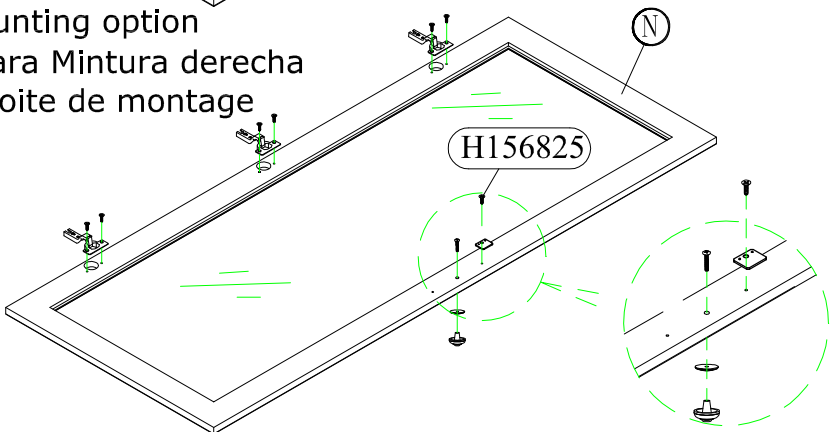

1 - 800 - 950 - 4782

A168086

# STEP 20

An assistant is required.  
Es necesario un ayudante.  
Un assistant est nécessaire.

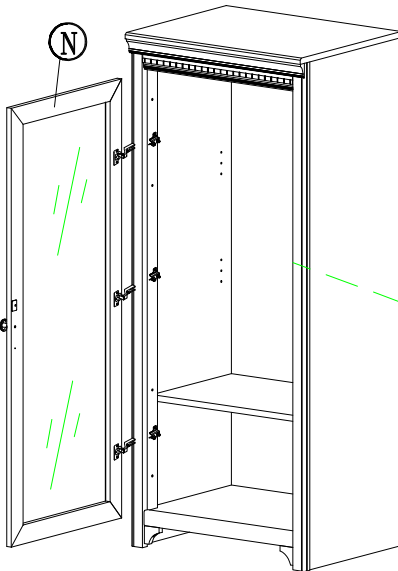
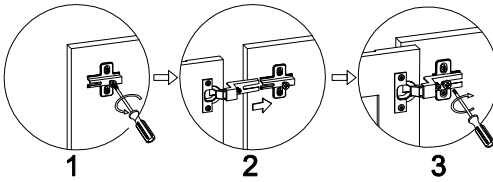

Left mounting option  
Opción para Mintura izquierda  
Option gauche de montage

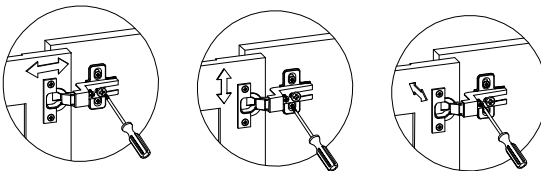
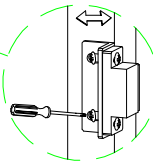

# STEP 21

An assistant is required.  
Es necesario un ayudante.  
Un assistant est nécessaire.

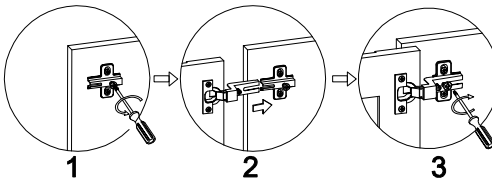

Right mounting option  
Opción para Mintura derecha  
Option droite de montage

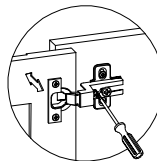
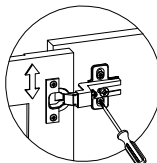
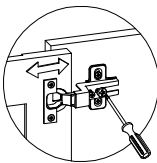
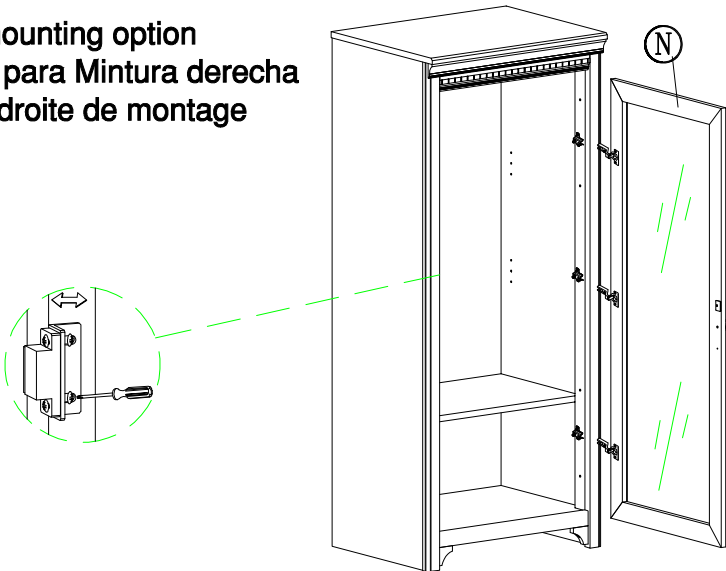

## STEP 22

H158707

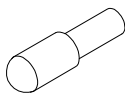

[ 8 ]

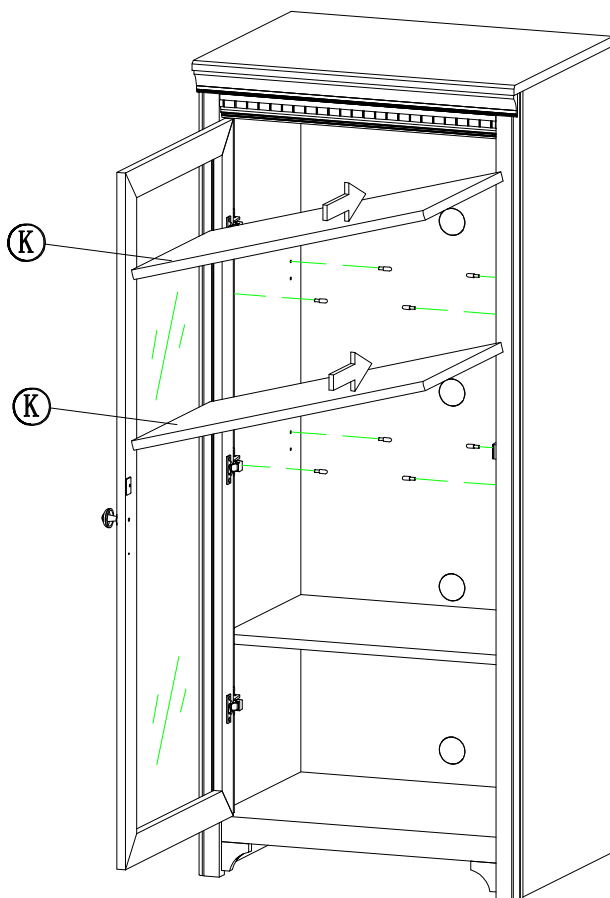

1 - 800 - 950 - 4782

A168086

## STEP 23

**Maximum Weight: 50 Lbs.**  
**Peso Máximo: 50 Libras**  
**Poids Maximum: 22.7 kilogramme**

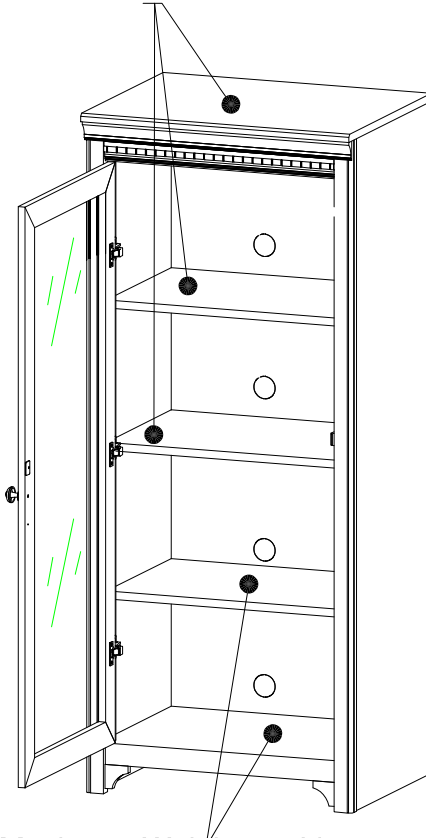

**Maximum Weight: 50 Lbs.**  
**Peso Máximo: 50 Libras**  
**Poids Maximum: 22.7 kilogramme**



# WARRANTY INFORMATION/INFORMATIONS POUR LA GARANTIE/INFORMACIÓN DE GARANTÍA

## BUSH FURNITURE'S WRITTEN WARRANTY TO YOU

In order to provide you with timely assistance, please thoroughly inspect your furniture for missing or defective parts immediately after opening the carton. To receive replacement or missing parts under this warranty, call our Consumer Service Department TOLL-FREE at 1-800-950-4782. Please have the Model, Part, and Lot Numbers found in the instruction manual available for your reference. You will also need your sales receipt or other proof of purchase. Replacement part(s) will be shipped to you at no charge with Bush Industries assuming all shipping and handling charges.

This Bush Furniture product is warranted to the original purchaser at the time of purchase and for a period of one year thereafter.

We warrant to you, the original purchaser, that our furniture and all its parts and components are free of defects in material or workmanship. "Defects," as used in this warranty, is defined as any imperfection which impairs the use of the furniture product.

Our warranty is expressly limited to the replacement of furniture parts and components. For one year after the date of purchase, Bush will replace any parts that are defective in material or workmanship.

This warranty applies under conditions of normal use. Our Bush Furniture products are not intended for outdoor use. This warranty does not cover: 1) defects caused by improper assembly or disassembly; 2) defects occurring after purchase due to product modification, intentional damage, accident, misuse, abuse, negligence or exposure to the elements; and 3) labor or assembly costs.

IMPLIED WARRANTIES, INCLUDING THE WARRANTY OF MERCHANTABILITY, SHALL NOT EXTEND BEYOND THE DURATION OF THE WRITTEN WARRANTY STATED ABOVE, AND IN NO EVENT SHALL BUSH BE LIABLE FOR INCIDENTAL OR CONSEQUENTIAL DAMAGES RESULTING FROM USE OF THE PRODUCT. Some states do not allow a limitation on how long an implied warranty lasts or the exclusion or limitation of incidental or consequential damages, so the above limitation and exclusion may not apply to you.

This warranty gives you specific legal rights. You may also have other rights that may vary from state to state.

## VOTRE GARANTIE BUSH FURNITURE

Afin de vous assister rapidement, veuillez inspecter votre mobilier en détail immédiatement après l'ouverture du carton en cas de pièces manquantes ou défectueuses. Pour recevoir une pièce de rechange ou manquante couverte par cette garantie, appelez notre département de service clientèle GRATUITEMENT au 1-800-950-4782. Veuillez tenir à disposition les numéros de modèle, de pièce et de lot qui se trouvent dans le manuel d'instruction pour votre référence. Vous aurez également besoin de votre reçu ou d'une autre preuve d'achat. La (les) pièce(s) de rechange vous sera (seront) envoyée(s) sans frais, Bush Industries se chargeant de tous les frais d'expédition.

Tout le produit Bush Furniture est garanti à l'acheteur original à partir de la date d'achat pour une période d'un an. Nous vous garantissons, à vous l'acheteur original, que notre mobilier et toutes ses pièces et composants sont sans défaut de matériau ou de fabrication. Le terme "défauts" utilisé dans cette garantie, est défini comme étant toutes les imperfections qui compromettent l'utilisation du meuble.

Notre garantie est expressément limitée au remplacement des pièces et des composants du mobilier. Pendant un an après la date d'achat, Bush remplacera toute pièce défectueuse dans le matériau ou sa fabrication.

Cette garantie d'applique sous des conditions d'utilisation normale. Nos produits Bush Furniture ne sont pas destinés à être utilisés en plein air. Cette garantie ne couvre pas: 1) les défauts causés par un mauvais assemblage ou démontage, 2) les défauts ayant lieu après l'achat et dus à la modification du produit, des dommages intentionnels, des accidents, une mauvaise utilisation, un mauvais traitement, la négligence ou l'exposition aux éléments, et 3) les frais de main d'œuvre ou d'assemblage.

LES GARANTIES TACITES, Y COMPRIS LA GARANTIE DE QUALITE MARCHANDE, NE S'ETENDRONT PAS AU-DELA DE LA DUREE ECRITE CITEE CI-DESSUS, ET BUSH NE SERA EN AUCUN CAS RESPONSABLE DES DOMMAGES ACCESSOIRES OU INDIRECTS RESULTANT DE L'UTILISATION DU PRODUIT. Certains états ne permettent pas d'appliquer une limite à la durée de la garantie tacite, ni une exclusion ou limitation des dommages accessoires ou indirects; dans ce cas les limitations ou exclusion ci-dessus peuvent ne pas s'appliquer à vous.

Cette garantie vous donne des droits légaux spécifiques. Il se peut que vous ayez également d'autres droits qui peuvent varier d'un état à l'autre.

## Garantía Escrita de Bush Furniture para usted

Para brindarle asistencia oportuna, por favor, verifique detalladamente que a su mueble no le falte o tenga piezas defectuosas inmediatamente después de abrir la caja. Pararecibir un reemplazo o la parte faltante bajo esta garantía, llame a nuestro Departamento de Servicio al Consumidor GRATIS al 1-800-950-4782. Sírvase traer los números de modelo, parte y lote que se encuentran en el manual de instrucciones disponible para su referencia. Además, necesitará el recibo de su compra u otra prueba de compra. La(s) pieza(s) de reemplazo le será(n) enviada(s) sin recargo por Bush Industries asumiendo los gastos de envío y manipuleo.

Todo mueble de Bush Furniture es garantizado al comprador original al momento de la compra y por un periodo de un año en adelante.

Le garantizamos a usted, el comprador original, que nuestros muebles sus partes y componentes están libres de defectos en materiales o trabajo. "Defectos", según se usa en esta garantía, se define como una imperfección que perjudica el uso del producto mobiliario.

Nuestra garantía se limita expresamente al reemplazo de partes y componentes mobiliarios. Durante un año después de la fecha de compra, Bush reemplazará cualquier parte defectuosa en material o trabajo.

Esta garantía se aplica bajo condiciones de uso normal. Nuestros productos de Bush Furniture no son para uso en exteriores. Esta garantía no cubre: 1) defectos causados por un ensamblaje o desensamblaje inadecuado; 2) defectos que ocurran después de la compra debido a modificación del producto, daño intencional, accidente, mal uso, abuso, negligencia o exposición a los elementos; y 3) costos de trabajo o ensamblaje.

LAS GARANTÍAS IMPLICADAS, INCLUYENDO LA GARANTÍA DE COMERCIABILIDAD, NO SE EXTENDERÁN MÁS ALLÁ DE LA DURACIÓN DE LA GARANTÍA ESCRITA MENCIONADA, Y EN NINGÚN CASO BUSH SERÁ RESPONSABLE POR DAÑOS INCIDENTALES O CONSIGUIENTES COMO RESULTADO DEL USO DEL PRODUCTO. Algunos estados no permiten una limitación sobre el tiempo de duración de la garantía implícita o la exclusión o limitación de daños incidentales o consiguientes, de manera que la limitación y exclusión mencionadas pueden no aplicarse para usted.

Esta garantía le otorga derechos legales específicos. Puede también tener otros derechos que pueden variar según los estados.

## PLEASE RETAIN THIS FOR YOUR RECORDS / VEUILLEZ CONSERVER CECI POUR VOS ARCHIVES POR FAVOR CONSERVE ESTE DOCUMENTO PARA SUS REGISTROS

You may need to refer to this information in case of warranty claim for insurance purposes.

Il se peut que vous ayez besoin de ces informations en cas de réclamation de garantie pour votre assurance.

Puede necesitar referirse a esta información, en caso de algún reclamo de la garantía con fines relacionados al seguro.

**Date Purchased/Date d'achat/Fecha de la Compra:** \_\_\_\_\_

**Store Name/Nom du magasin/Nombre de la Tienda:** \_\_\_\_\_

**Model #/Modèle #/Modelo #:** \_\_\_\_\_

**Product Description/Description du produit/Descripción del Producto:** \_\_\_\_\_

**Lot Code:** \_\_\_\_\_