

## Commissioning

- Ensure that all the connections are tight
- Connect the power supply to the mains and turn on.

## Operating the remote control and replacing the battery

- There are various colour mode variations as shown below.
- To replace the battery, release the compartment from inside the remote control by pushing the lever at the bottom left of the compartment. Pull the battery housing out and replace the exhausted battery with a new one - make sure the polarity is correct. Then slide the compartment back inside the remote control.
- Heed the battery care information noted in the Warning section overleaf.

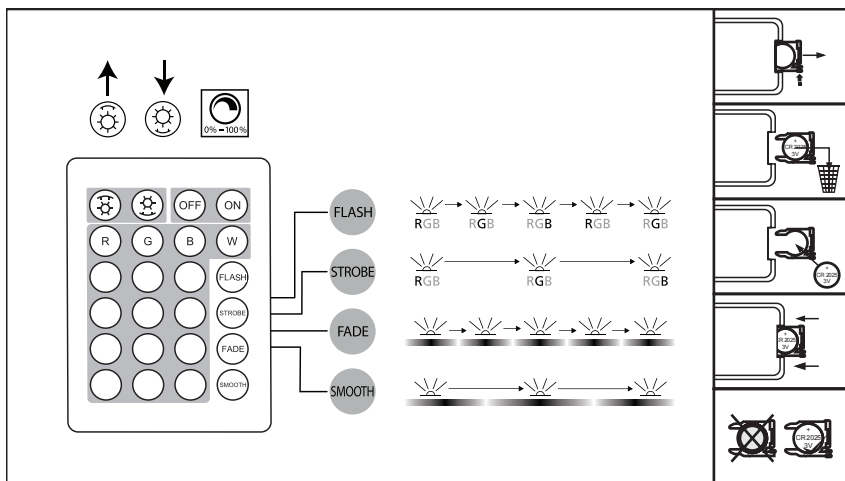

## Recycling advice

 Waste electrical products should not be disposed of with household waste. Please recycle where facilities exist. Check with your Local Authority or retailer for recycling advice.

## Safety information

For your safety, always switch off the supply before maintaining or cleaning.

## Instruction leaflet

# Flexline 12V RGB

52316

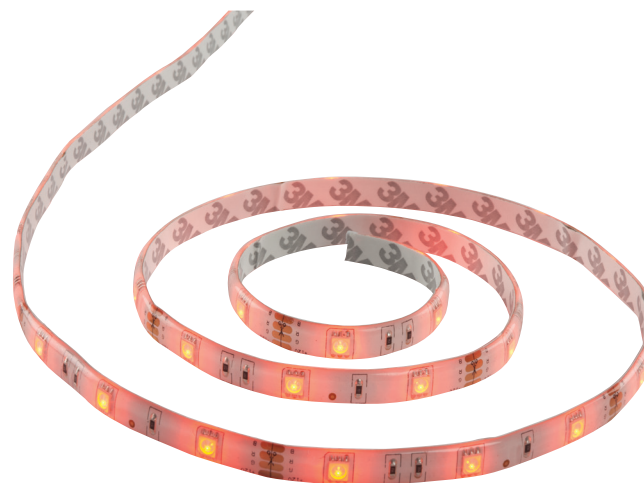

CE

saxby  
lighting

Thank you for purchasing this light fitting. Please read the instructions carefully before use to ensure safe and satisfactory operation of this product. Please retain these instructions for future reference.

## Warning

**This is a Class 3 product and requires the use of a LED Driver (not supplied).**

Please read these instructions carefully before commencing any work.

This unit must be fitted by a competent and qualified electrician.

Install in accordance with IEE Wiring regulations and current Building Regulations.

This system operates at Safety Extra Low Voltage (12V d.c.), via a LED driver. Never connect the LED strips directly to the mains without using the correct LED driver.

Always unplug the LED driver from the mains when installing or maintaining this system.

This product contains non-replacable parts and cannot be serviced. If damage occurs the part should be scrapped.

Waste electrical products should not be disposed of with household waste. Please recycle where facilities exist. Check with your local authority or retailer for recycling advice.

**Battery care:** Do not recharge non-rechargeable batteries. Do not mix old and new batteries or batteries of different types.. Do not use rechargeable batteries. Always remove exhausted batteries from the remote control. Always insert the battery with the correct polarity. Do not short circuit the supply terminals. This product is suitable for use by adults only.

## Specification

Dimensions : 10mm wide, 2.5mm high x 5000mm long  
Voltage : 12V d.c.

## LED Strips

52316 : Flexline 5m 5050 LED RGB 12V

## LED Drivers

51925 : LED driver constant voltage - 24W 12V

51926 : LED driver constant voltage - 60W 12V

## Accessories

52323 : Flexline Accessory Pack containing :-

- 2 connection leads	- 8 short 4 pin connectors
- 1 blanking plug	- 16 self tapping screws
- 8 clips	- 4 corner connectors
- 1 remote control	

## Layout

- Ensure that you select the correct power supply for the length required. If using driver 51925, this product can be driven to a maximum length of 5m. If using driver 51926, this product can be driven to a maximum of 10m.
- The Flexline LED's are mounted on a sticky tape which can be stuck to most surfaces.
- The Flexline LED's can be shortened to a minimum of 100mm or multiples of 100mm.
- Plan the desired layout of this fitting carefully,

ensuring the cables will reach the distance between the power supply and the Flexline LED's.

- Avoid locating any cables in positions that would cause a hazard. Position cables and Flexline LED's (not supplied) away from areas where they may be at risk from being cut, trapped or damaged.
- Cables in walls must be protected using suitable conduit or plastic trunking.
- This product no has special protection against the ingress of moisture.

## Basic Installation

- Position the LED driver next to the mains outlet socket that the system will connect to. Do not plug-in at this stage.
- After deciding the layout of the LED strips, ensure the cables are long enough to connect to the desired positions.
- Cut to the desired length. The maximum permissible length of 12V SMD LED's for each driver is listed in the layout section above. Ensure that the cut is made at the copper connection points.
- Peel the backing tape off the Flexline strip. Apply

moderate pressure to stick the LED's the surface. An assistant may be required to help stick longer lengths accurately.

- Connect power lead to end of LED strip - ensuring polarity arrows line up.
- Connect the power connector to the LED driver.
- Connect remote control receiver unit.
- Connect the power supply to the mains and turn on.

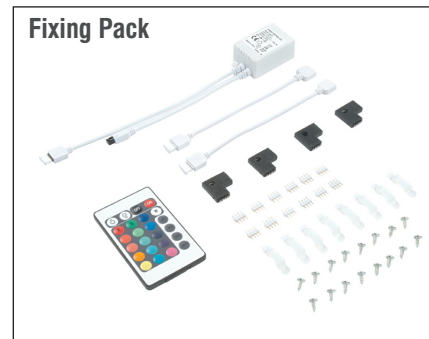
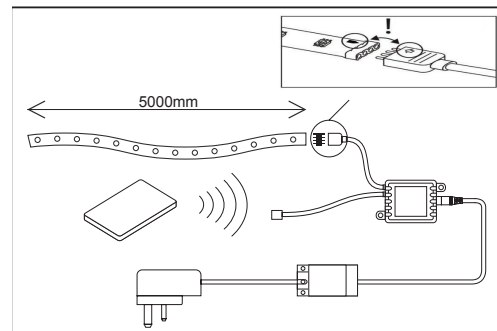

## Connecting Strips - using accessory pack 52323 (picture above)

- For LED strips and connectors: just push together to connect - use supplied brackets to secure to mounting surface.
- For corner connections: use corner connectors or connection cables
- For Inline connections: use 4 pin connectors