

Commissioning

- Ensure that all the connections are tight
- Connect the power supply to the mains and turn on.

Recycling advice



Waste electrical products should not be disposed of with household waste. Please recycle where facilities exist. Check with your Local Authority or retailer for recycling advice.

Safety information

For your safety, always switch off the supply before maintaining or cleaning.

Instruction leaflet

Flexline 24V

52317, 52318, 52319



saxby
lighting

Iss.4 03122014

Thank you for purchasing this light fitting. Please read the instructions carefully before use to ensure safe and satisfactory operation of this product. Please retain these instructions for future reference.

Warning

This is a Class 3 product and requires the use of a LED Driver (not supplied).

Please read these instructions carefully before commencing any work.

This unit must be fitted by a competent and qualified electrician.

Install in accordance with IEE Wiring regulations and current Building Regulations.

This system operates at Safety Extra Low Voltage (24V d.c.), via a LED driver. Never connect the LED strips directly to the mains without using the correct LED driver.

Always unplug the LED driver from the mains when installing or maintaining this system.

This product contains non-replacable parts and cannot be serviced. If damage occurs the part should be scrapped.

Waste electrical products should not be disposed of with household waste. Please recycle where facilities exist. Check with your local authority or retailer for recycling advice.

Specification

Dimensions : 10mm wide, 2.5mm high x 1000mm long
Voltage : 24V

LED Strips

52317 : Flexline 1m 5050 LED Warm White 24V
52318 : Flexline 1m 5050 LED Cool White 24V
52319 : Flexline 1m 5050 LED Blue 24V

LED Drivers

52324 : LED driver constant voltage - 100W 24V multiple output
52325 : LED driver constant voltage - 200W 24V multiple output

Accessories

52322 : Flexline Accessory Pack containing :-
- 2 connection leads - 12 short 4 pin connectors
- 16 self tapping screws - 4 corner connectors
- 8 clips - 1 50cm Power lead

Layout

- Ensure that you select the correct power supply for the length required. If using driver 52324, this product can be driven to a maximum length of 5m. If using driver 52325, this product can be driven to a maximum of 10m.
- The Flexline LED's are mounted on a sticky tape which can be stuck to most surfaces.
- The Flexline LED's can be shortened to a minimum of 100mm or multiples of 100mm.
- Plan the desired layout of this fitting carefully,

ensuring the cables will reach the distance between the power supply and the Flexline LED's.

- Avoid locating any cables in positions that would cause a hazard. Position cables and Flexline LED's (not supplied) away from areas where they may be at risk from being cut, trapped or damaged.
- Cables in walls must be protected using suitable conduit or plastic trunking.
- This product no has special protection against the ingress of moisture.

Basic Installation

- Position the LED driver next to the mains outlet socket that the system will connect to. Do not plug-in at this stage.
- After deciding the layout of the LED strips, ensure the cables are long enough to connect to the desired positions.
- Cut to the desired length. The maximum permissible length of 24V SMD LED's for each driver is listed in the layout section above. Ensure that the cut is made at the copper connection points.
- Peel the backing tape off the Flexline strip. Apply

moderate pressure to stick the LED's the surface. An assistant may be required to help stick longer lengths accurately.

- Connect power lead to end of LED strip - ensuring polarity arrows line up.
- Connect the power connector to the LED driver.
- Connect remote control receiver unit.
- Connect the power supply to the mains and turn on.

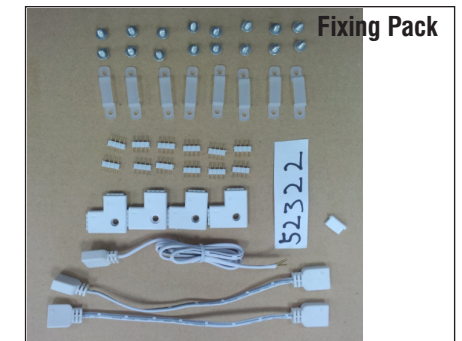
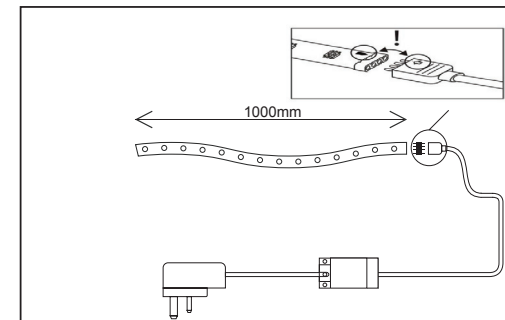

Connecting Strips - using accessory pack 52322 (picture above)

- For LED strips and connectors: just push together to connect - use supplied brackets to secure to mounting surface.
- For corner connections: use corner connectors or connection cables
- For Inline connections: use 4 pin connectors