

## Wiring

**This unit is double insulated and must not be earthed.**

- The appliance is fitted to a rewireable 3 pin plug fitted with a 3 amp fuse. Should the fuse require replacement, it must be replaced with a fuse rated at 3 amp and approved to BS1362.
- Either directly wire the power lead to a fused outlet socket. The Brown wire must be connected to the terminal marked L or coloured red. The Blue wire must be connected to the terminal marked N or coloured black. Use a 3 Amp Fuse approved to BS1362.
- If the mains plug is unsuitable for the socket outlet or is removed for any other reason, then the cut off plug should be disposed of safely to prevent the hazard of electric shock.

- There is a danger of electric shock if the cut off plug is inserted into any 13 amp socket outlet.
- The wires in the mains lead on this appliance are coloured in accordance with the following code:  
Blue – Neutral  
Brown – Live
- Use a 3 Amp Fuse approved to BS1362.

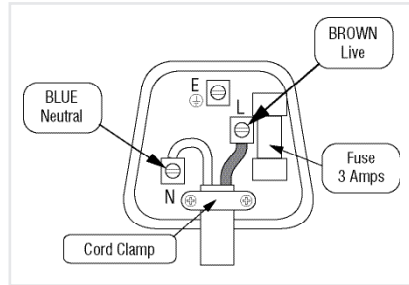

## Commissioning

- Plug in and test.
- Your lights are now ready for use.

## Fitting/replacing bulbs

- This system contains non-replaceable parts and cannot be serviced.

If damage occurs the part should be scrapped.

- Always switch off or disconnect from the mains when cleaning the product.
- We recommend cleaning with a soft dry cloth. Never use scourers, abrasives or chemical cleaners.
- Do not allow moisture to come into contact with electric parts.

## Recycling advice



Waste electrical products should not be disposed of with household waste. Please recycle where facilities exist. Check with your Local Authority or retailer for recycling advice.

## Safety information

For your safety, always switch off the supply before cleaning.

## Instruction leaflet

# Nyx Undercabinet Kit

59877, 59878, 59879, 59880



saxby  
lighting

Thank you for purchasing this light fitting. Please read the instructions carefully before use to ensure safe and satisfactory operation of this product. Please retain these instructions for future reference.

## Warning



**This product is Double Insulated and does not require connection to an Earth circuit.**



**The LED units are Safety Extra Low Voltage and must not be earthed.**

Please read these instructions carefully before commencing any work.

This unit must be fitted by a competent and qualified electrician.

Install in accordance with IEE Wiring regulations and current Building Regulations.

This system operates at Safety Extra Low Voltage (12V), via a LED driver. Never connect the light fittings directly to the mains without using a LED driver.

Ensure that a correctly rated LED driver is used.

Do not exceed the LED driver load. This is a self contained unit and cannot be extended. The triple kits (59877/59879) can connect up to a maximum of 5 heads (from add on kits - 59878/59880).

Always unplug the LED driver from the mains when installing or maintaining this system.

This system contains non-replaceable parts and cannot be serviced. If damage occurs the part should be scrapped.

This product cannot be dimmed.

Waste electrical products should not be disposed of with household waste. Please recycle where facilities exist.

Check with your local authority or retailer for recycling advice.

## Specification

Voltage: 240V ~ 50Hz  
 Lamp: 59877/59879: 3 x 2.5W LED Module (SMD 2835) Warm White - 570lm  
 59878/59880: 2.5W LED Module (SMD 2835) Warm White - 190lm  
 IP rating: 20

## Layout

- Plan the desired layout of these fittings carefully, ensuring the cables will reach the distances between the driver, connector block and each LED unit.
- This product is designed for use under kitchen cupboards, bookshelves, cabinets etc. Suitable for indoor use only. Not suitable for bathrooms.
- Do not attach to surfaces which are damp, freshly painted or otherwise electrically conductive (e.g. metallic surfaces).
- The chosen location should allow for the product to be securely mounted and safely connected to the mains supply (240V wall socket).
- Ensure that there is adequate ventilation for the driver.
- Avoid locating any cables in positions that would cause a hazard. Position cables and connector block away from areas where they may be at risk from being cut, trapped or damaged.
- Cables that are to be in walls must be protected using suitable conduit or plastic trunking.

## Installation

- Lay out/ measure the positions of the head units as desired. Ensure you route cables to avoid accident or damage occurring. Cables can be taped to mounting surface after installation.
- Each head unit is supplied with 1.3m of cable, so the recommend max. distance between head to next head is 1.2m. The triple kits (59877/59879) can connect up to a maximum of 5 heads (from add on kits - 59878/59880).
- These fittings can be surface mounted using the supplied bracket or can be recessed without the bracket (Fig. 1). Carefully push on the rear of the head and separate the LED head unit from the mount bracket.
- For recessed fitting, cut a 57mm hole in the mounting surface and the minimum mount board thickness is 12mm.
- For surface mounted fitting, fix the bracket onto the mounting surface by the fixing screws provided
- For surface mounted fitting, the cable can be laid flat by passing the cable through the side slot in mounting bracket, OR the cable can be located at the back of the mounting hole. Drill a 12mm dia. hole and pass the connector & cable through this hole.
- Plug the cable connector to the head socket (Fig. 2).
- After all the connectors are connected, carefully push the LED head unit back into position (mount bracket or recessed cut hole).

Fig. 1

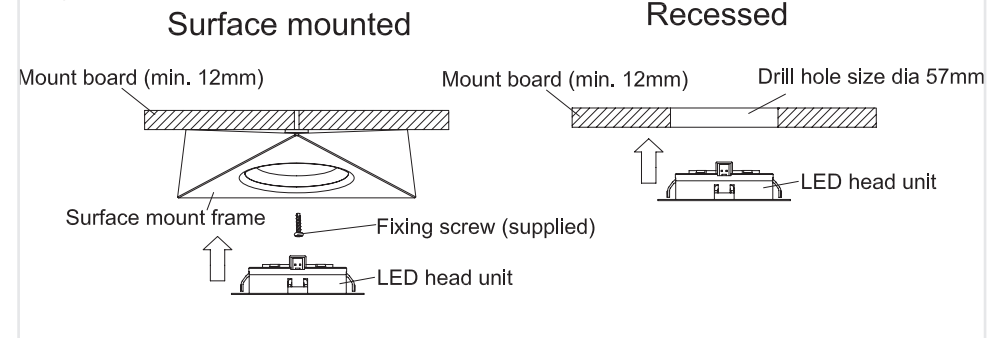

Fig. 2

