

Commissioning

- The ceiling surface must be flat and smooth to ensure a good fit.
- Push the spring clips upwards and fit into the ceiling hole. See Fig 1.
- Push the unit up until firmly in position, ensuring that no cables are trapped. See Fig 2.
- Ensure that the product is sitting properly in the hole.
- Replace fuse or circuit breaker and switch on. Your light is now ready for use.

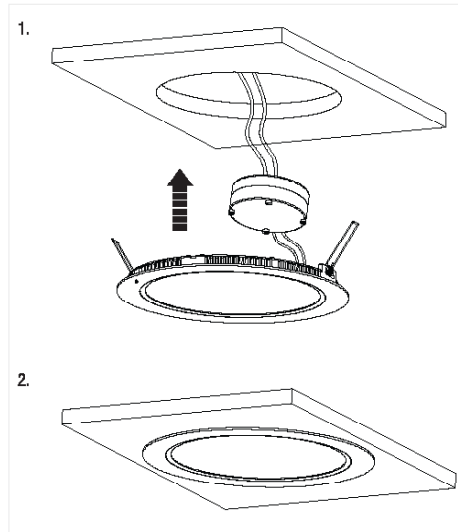

Fitting/replacing bulbs

- The LED's in this product are non replaceable.
- We recommend cleaning with a soft dry cloth. Do not use solvents or abrasive cleaners as these could damage the finish.

Recycling advice



Waste electrical products should not be disposed of with household waste. Please recycle where facilities exist. Check with your Local Authority or retailer for recycling advice.

Safety information

For your safety, always switch off the supply before cleaning.

Instruction leaflet

Orbital Recessed

60320, 60319



saxby
lighting

Thank you for purchasing this light fitting. Please read the instructions carefully before use to ensure safe and satisfactory operation of this product. Please retain these instructions for future reference.

Warning

This light fitting is Double Insulated and does not require connection to an Earth circuit.

Please read these instructions carefully before commencing any work.

This unit must be fitted by a competent and qualified electrician.

Install in accordance with IEE Wiring regulations and current Building Regulations.

This system operates at Safety Extra Low Voltage, via the supplied LED driver. Never connect the light fittings directly to the mains without using the supplied LED driver.

Always disconnect the LED driver from the mains when installing or maintaining this system.

To prevent electrocution switch off at mains supply before installing or maintaining this fitting. Ensure other

persons cannot restore the electrical supply without your knowledge.

This light fitting should be connected to a fused circuit.

If replacing an existing fitting, make a careful note of the connections.

This fitting must always be fitted to a plasterboard ceiling. This must not be fitted to a plaster and lathe ceiling

This system contains non-replaceable parts and cannot be serviced. If damage occurs the part should be scrapped.

Specification

Voltage: 240V 50Hz
Lamp: 1 x 5W SMD 2835 (Orbital)
IP rating: 20

Layout

- Plan the desired layout of these fittings carefully, ensuring the cables will reach the distances between the transformer and each light fitting.
- Ensure that there is adequate ventilation for the transformer.
- Avoid locating any cables in positions that would cause a hazard. Position cables and junction boxes (not supplied) away from areas where they may be at risk from being cut, trapped or damaged.
- The mains supply cable must have a minimum cross sectional area of 1.0mm².
- The distance between units must be 0.5m minimum.
- The unit must be located 0.2m away from a joist.
- This product must be mounted out of arms reach.

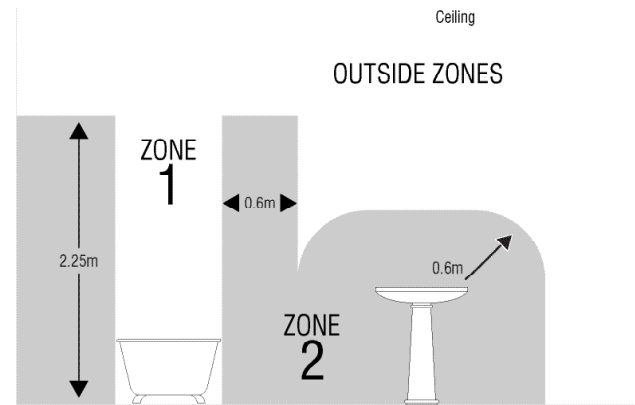

This product is suitable for use in Zone 2 and outside Zones of a bathroom. See diagram. If this unit is being fitted in a room containing a bath or shower, a 30mA RCD must be used - in accordance with IEE regulations.

Installation

Existing fittings must be completely removed before installation of a new product. Before removing the existing fitting, **carefully note the position of each set of wires.**

- Position the LED Driver next to the mains outlet that the system will connect to. Do not connect at this stage.
- Cut a 90mm diameter hole using an appropriate tool.
- Ensure that the void depth is a minimum of 100mm.
- It is recommended to cut the hole slightly smaller than

needed, then file the hole until the recessed unit fits snugly.

- Ensure free movement of air by removing void insulation from at least 150mm from around the hole. Under no circumstances must these fittings be covered with insulating matting or similar material.

Wiring

Having correctly identified the wiring from your existing light fitting, pull the wire through the hole and connect to the connection block inside the LED driver in the following way: This unit is double insulated and must not be earthed. If there are any incoming earth cables, they must be joined

together and well insulated with good quality insulation tape. This is to ensure earth continuity throughout your property.

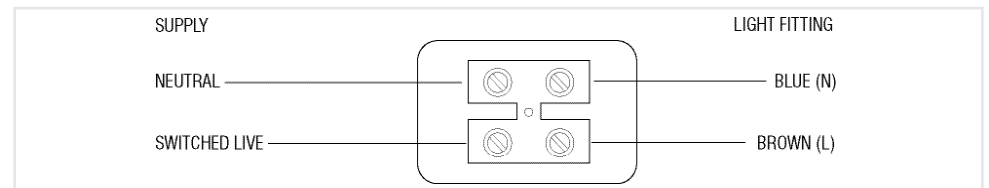

Check that...

- You have correctly identified the wires.
- The connections are tight.
- No loose strands have been left out of the connection block.