

Model Modèle Modelo

52412-1168-1268-1368

**ASSEMBLY INSTRUCTIONS**  
**INSTRUCTIONS D'ASSEMBLAGE**  
**INSTRUCCIONES DE ENSAMBLE**

Cappuccino Cherry & Slate / Cerisier Cappuccino et Ardoise  
Cerezo Cappuccino y Pizarra

52412-1169-1269-1369

Chocolate / Chocolat / Chocolate

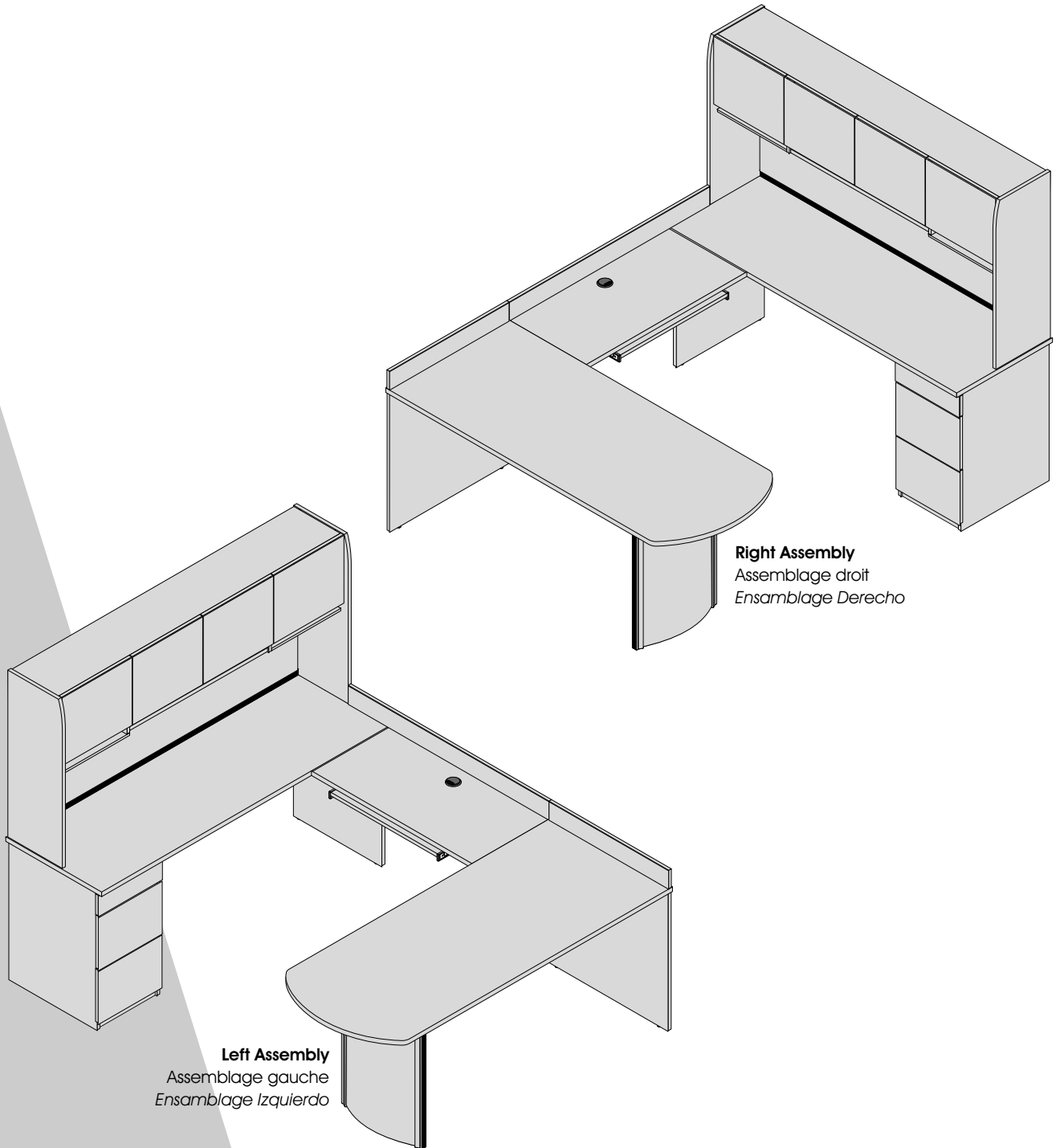

**Left Assembly**  
Assemblage gauche  
Ensamblaje Izquierdo

**Right Assembly**  
Assemblage droit  
Ensamblaje Derecho

 **bestar**  
Certified/Certifié/Certificado  
ISO 9001

SERVICE/SERVICIO: 1-888 8BESTAR (1-888 823-7827)

[www.bestar.ca](http://www.bestar.ca)

## Thank you for choosing a Bestar product. Your total satisfaction is our #1 priority

### CUSTOMER SERVICE AND WARRANTY INFORMATION

Should you have a problem or need more information concerning the warranty, **do not call to the place of purchase.**

Please call our customer service department for immediate assistance using the following toll free number : **1-888-823-7827**

**Monday to Thursday : 8H30 AM to 8H30 PM E.S.T. Friday : 8H30 AM to 4H00 PM E.S.T. Saturday : 10H00 AM to 4H30 PM E.S.T.**

Please have your assembly instruction manual on hand when you call.

Bestar products are warranted to the original purchaser against defects in material or workmanship in the furniture. Defects as mentioned in this warranty refer to any imperfections which may impair the use of the product. Our warranty is expressly limited to the replacement of furniture parts and components for five years following the date of purchase. Bestar will replace any part that is defective. This warranty applies under conditions of normal use. Our furniture products are not intended for outdoor use. The warranty does not cover defects caused by improper assembly or disassembly, defects occurring after purchase due to product modifications, intentional damage, accident, misuse, exposure to the elements and labor or assembly costs.

Bestar reserves the right to request proof of purchase to document a warranty claim.

In no event shall Bestar be liable for incidental or consequent damages resulting from the misuse of the product.

This warranty is not transferable and is valid only in Canada and the United States excluding Alaska, Hawaii and Puerto Rico.

## Merci d'avoir choisi les produits Bestar. Vous satisfaire est notre priorité

### SERVICE À LA CLIENTÈLE ET INFORMATIONS RELATIVES À LA GARANTIE

Si vous rencontrez un problème ou si vous souhaitez de plus amples informations concernant votre garantie, **ne vous adressez pas au magasin où vous avez effectué votre achat.** Pour obtenir une aide immédiate, veuillez appeler notre service après-vente au numéro sans frais suivant : **1-888-823-7827**

**Lundi au jeudi : 8H30 à 20H30 HNE**

**Vendredi : 8H30 à 16H00 HNE**

**Samedi : 10H00 à 16H30 HNE**

Veillez avoir en main le manuel d'instructions lors de votre appel.

La garantie des produits Bestar est valide, pour l'acheteur original, en cas de défaut de matériel ou de fabrication. Les défauts couverts par cette garantie incluent toutes les imperfections qui ont pour conséquence une utilisation non appropriée du produit. Notre garantie est expressément limitée au remplacement des composants et des éléments de meubles pour une durée de cinq ans suivant la date de l'achat. Bestar s'engage à remplacer tout élément défectueux. Cette garantie s'inscrit dans le cadre d'une utilisation du produit dans des conditions normales. Nos meubles ne sont pas destinés à être utilisés à l'extérieur. La garantie ne couvre pas les défauts générés par un assemblage ou un démontage non conforme, les défauts apparus suite à des modifications apportées au produit, à des dommages intentionnels, à un accident, une mauvaise utilisation, l'utilisation à l'extérieur, ni les coûts de main d'œuvre ou d'assemblage.

Bestar se réserve le droit d'exiger une preuve d'achat afin de documenter la réclamation. La société Bestar ne pourra être tenue, en aucun cas, responsable de dommages indirects ou consécutifs, suite à une mauvaise utilisation du produit.

Cette garantie ne peut être transférée et est valide au Canada et aux États-Unis sauf Hawaï, Puerto Rico et Alaska.

## Gracias por elegir un producto Bestar. Su entera satisfacción es nuestra prioridad N°1

### SERVICIO DE ATENCIÓN AL CLIENTE E INFORMACIÓN SOBRE LA GARANTÍA

Si tiene algún problema y necesita más información sobre la garantía, **no vaya al lugar donde realizó la compra.** Llame a nuestro departamento de atención al cliente para recibir ayuda inmediata utilizando nuestro servicio de llamada gratuita : **1-888-823-7827**

**De lunes a jueves : de 8H30 AM a 8H30 PM EST Viernes : de 8h30 AM a 4H30 PM EST Sábados : de 10h00AM a 16h30 PM EST**

Cuando llame, tenga a mano su manual de instrucciones de montaje.

Los productos Bestar están garantizados por el comprador original contra defectos en el material o en la confección del mueble. Los defectos, tal como se describen en esta garantía incluyen toda imperfección que pueda impedir el uso del producto. Nuestra garantía se limita expresamente al reemplazo de las partes y componentes del mueble defectuosos por cinco años a partir de la fecha de compra. Bestar reemplazará cualquier pieza defectuosa. Esta garantía se aplica según las condiciones de uso normal. Nuestros productos no están diseñados para ser utilizados al aire libre. La garantía no cubre defectos provocados por ensamblaje o desensamblaje incorrectos, defectos ocurridos luego de la compra por la modificación del mueble, daños intencionales, accidentes, uso incorrecto, exposición a los agentes naturales ni costos derivados de la fabricación o ensamblaje.

Bestar se reserva el derecho de solicitar una factura de compra para poder extender un reclamo de garantía.

Bajo ninguna circunstancia Bestar será responsable de los daños accidentales o consecuentes que pudieran resultar del uso incorrecto del producto.

Esta garantía es intransferible y se aplica solamente a Canadá y los Estados Unidos.

**HEAD OFFICE AND FACTORY / BUREAU CHEF ET USINE / OFICINA CENTRAL Y FÁBRICA  
4220, rue Villeneuve, Lac-Mégantic, Qc CANADA G6B 2C3 tél.: (819) 583-1017**

**SERVICE/SERVICIO: 1-888 8BESTAR (1-888 823-7827)**

**PARTS / PIÈCES / PIEZAS**

CODE / CÓDIGO	QTY / QTÉ / CANT.	CODE / CÓDIGO	QTY / QTÉ / CANT.	CODE / CÓDIGO	QTY / QTÉ / CANT.	CODE / CÓDIGO	QTY / QTÉ / CANT.
CA03A	2	31	1	46	1	82	1
CA05A	2	32	1	60	2	83	1
CA09A	4	33	1	61	2	84	1
CA13A	4	34	1	66	1	<b>moldings / moulures / molduras</b> 1 7/16" x 29 1/8" (37 mm x 740 mm)	2
17	1	40	1	67	2	<b>back panel / dos / panel trasero</b> 13 3/8" x 70 9/16" (340 mm x 1792 mm)	1
18	1	TC40C	1	70	1	<b>bottom / fond / fondo</b> 15 3/8" x 12 7/16" (391 mm x 316 mm)	3
20	1	41	1	71	1	<b>panel / panneau / panel</b> 18 5/8" x 29 1/8" (472 mm x 740 mm)	1
21	1	42	1	72	1		
22	1	43	1	73	1		
23	1	44	1	75	1		
30	1	45	1	CA80B	1		

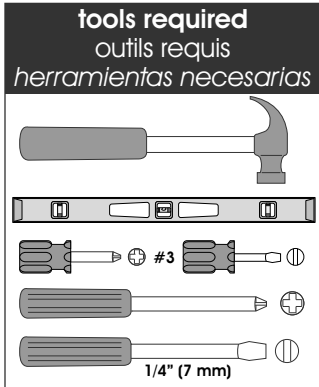



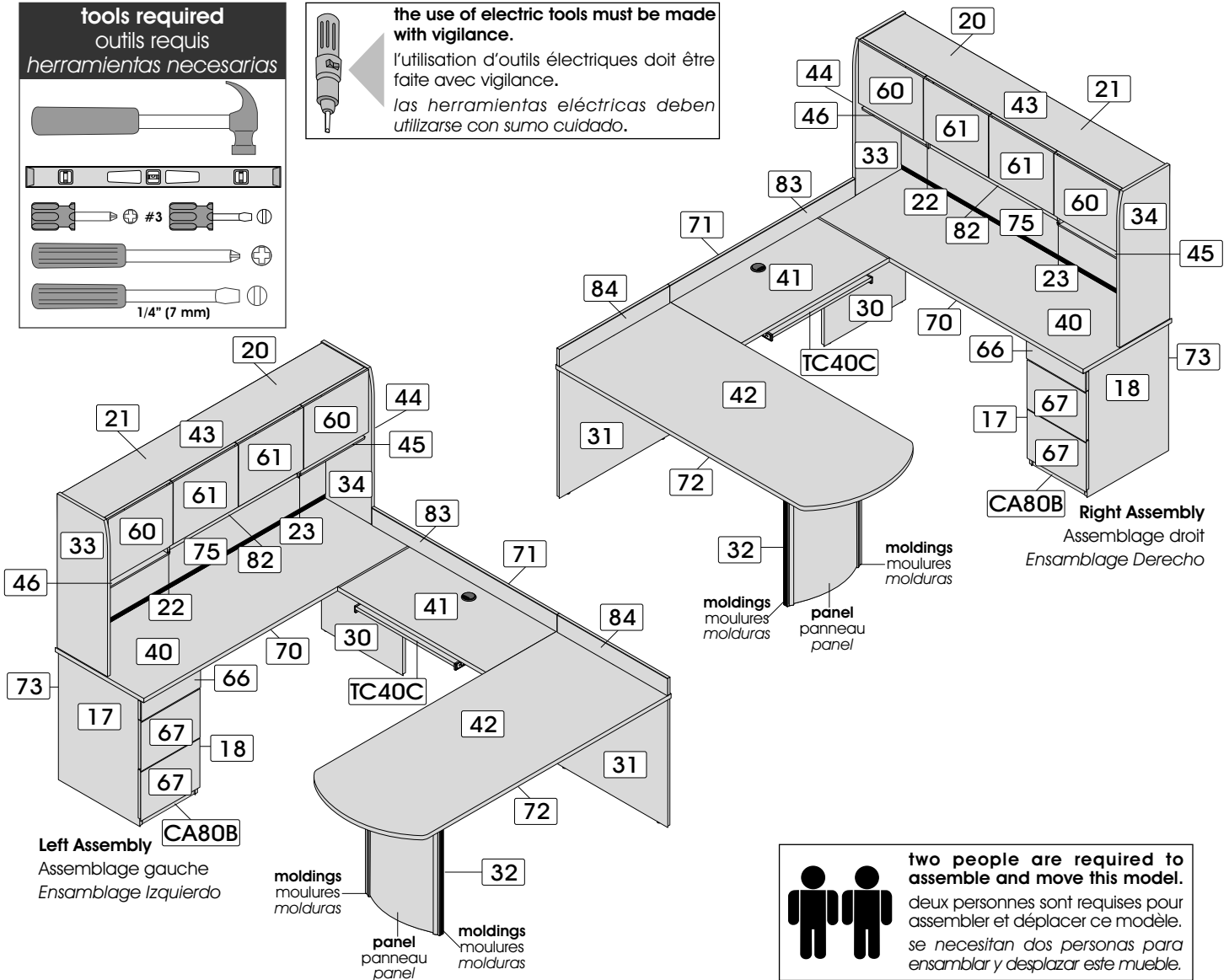









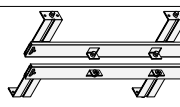



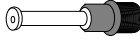





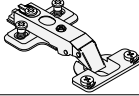
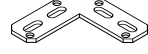

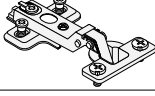
**the use of electric tools must be made with vigilance.**  
l'utilisation d'outils électriques doit être faite avec vigilance.  
*las herramientas eléctricas deben utilizarse con sumo cuidado.*



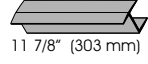

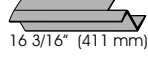
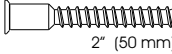

**two people are required to assemble and move this model.**  
deux personnes sont requises pour assembler et déplacer ce modèle.  
*se necesitan dos personas para ensamblar y desplazar este mueble.*

**HARDWARE / QUINCAILLERIES / QUINCALLAS**

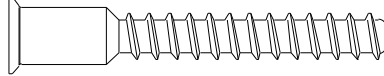
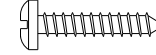
CODE / CÓDIGO	QTY / QTÉ / CANT.	CODE / CÓDIGO	QTY / QTÉ / CANT.	CODE / CÓDIGO	QTY / QTÉ / CANT.	CODE / CÓDIGO	QTY / QTÉ / CANT.
AM-182 	10	CO-762 <b>runners 400 mm (15 3/4")</b> coulisseaux 400 mm correderas 400 mm	1	H-03 	52	VM-601 	6
CA-77 	2	CO-843 	1	H-04 	4	VP-218 	4
CA-99 	27	CR-141 	4	H-36 	48	VR-207 	35
CA-100 	4	EC-744 	6	PA-844 	10	VR-210 	16
CH-838 	4	EQ-143 	4	PF-108 	1	VR-212 	28
CH-840 	4	EQ-314 	3	SE-686 	2		
CL-140 	-	EX-681 	4	TI-552 	4		
CL-745 	1	EX-702 	4	VC-204 	11		
CO-249 <b>runners 406 mm (16")</b> coulisseaux 406 mm correderas 406 mm	2	EX-766 	1	VE-244 	16		

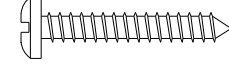
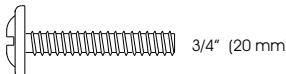
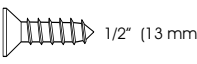
**REAL SIZE / GRANDEUR RÉELLE / TAMAÑO REAL**

CODE / CÓDIGO	QTY / QTÉ / CANT.	CODE / CÓDIGO	QTY / QTÉ / CANT.
VC-204 	11	VR-210 	16
VE-244 	16	VR-212 	28
VM-601 	6		
VP-218 	4		
VR-207 	35		

**IMPORTANT NOTICE / NOTE IMPORTANTE / NOTA IMPORTANTE**

**Group together all the hardware required for each step as the construction of your piece of furniture is progressing.**  
 Regroupez toutes les quincailleries requises pour chaque étape de façon à vous assurer de tout installer au bon moment.  
 Reúna todas las artículos de ferretería necesarias para cada una de las etapas de montaje, para asegurar una correcta instalación en el momento adecuado.

# ▶ IMPORTANT NOTICE / NOTE IMPORTANTE / NOTA IMPORTANTE

Duly complete the self-adhesive sticker. / Assurez-vous de bien remplir l'autocollant. / Asegúrese de completar correctamente la etiqueta.



Production : # 0000

**bestar** To better serve you!  
Pour mieux vous servir!

Model / Modèle: \_\_\_\_\_

Production Number  
Numéro de production: \_\_\_\_\_

Customer Service  
Service à la clientèle **1-888-823-7827**

**Important/Importante**

Please retain the self-adhesive sticker which you will install at step 25 of the instruction manual.

Conservez l'autocollant qui sera collé seulement à l'étape 25 du feuillet d'instructions.

Conserve la etiqueta que será pegada sólo en la etapa 25 de la hoja de instrucciones.

# ▶ IMPORTANT NOTICE / NOTE IMPORTANTE / NOTA IMPORTANTE

**Main hardware system / Système de quincaillerie principal / Sistema principal de quincalla**

**1**  
H-36

proper position  
bonne position  
buena posición

**2**  
H-03

arrow  
flèche  
flecha

Insert the cam with the arrow pointing towards the hole in the edge.  
Insérez la rondelle en pointant la flèche vers le trou de la bordure.  
Inserte la arandela apuntando la flecha hacia el orificio cercano el borde.

**If needed / En cas de nécessité / En caso de necesidad**

**How to remove a misplaced assembly bolt (H-36).  
Comment retirer un boulon (H-36) mal situé.  
Cómo retirar un perno (H-36) mal ubicado.**

**A**

turn  
toumez  
haga girar

**B**

pull out  
retirez  
retire

SERVICE/SERVICIO: 1-888 8BESTAR (1-888 823-7827)

Desk / Bureau / Escritorio

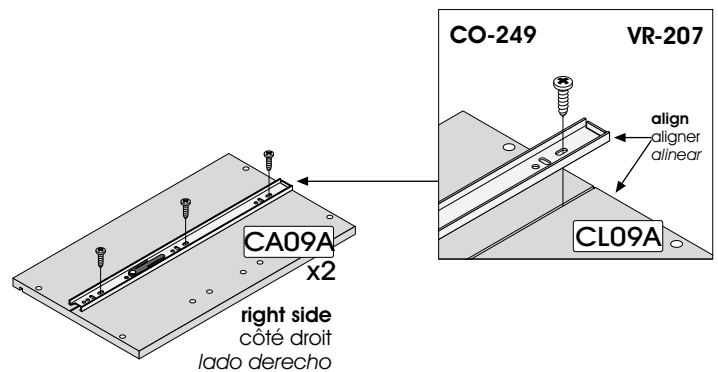
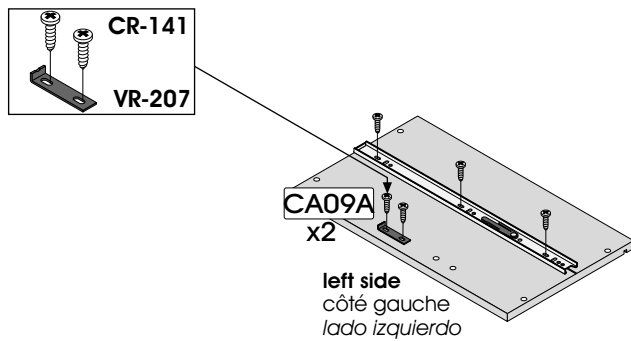
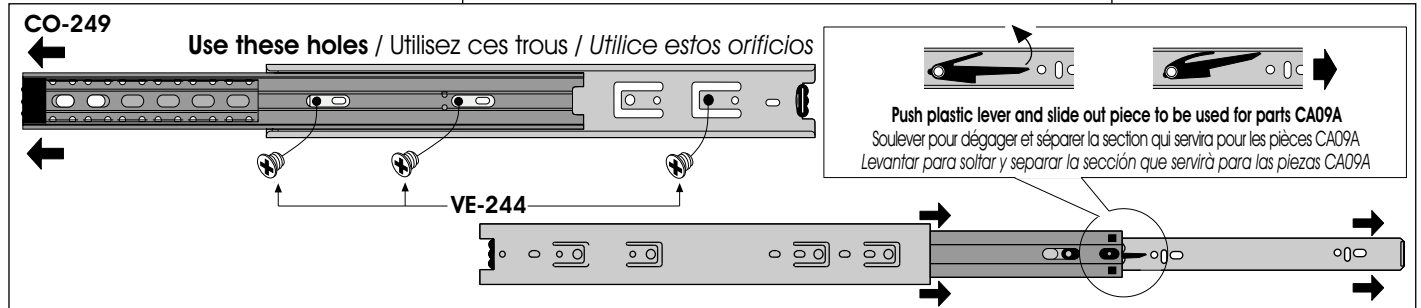
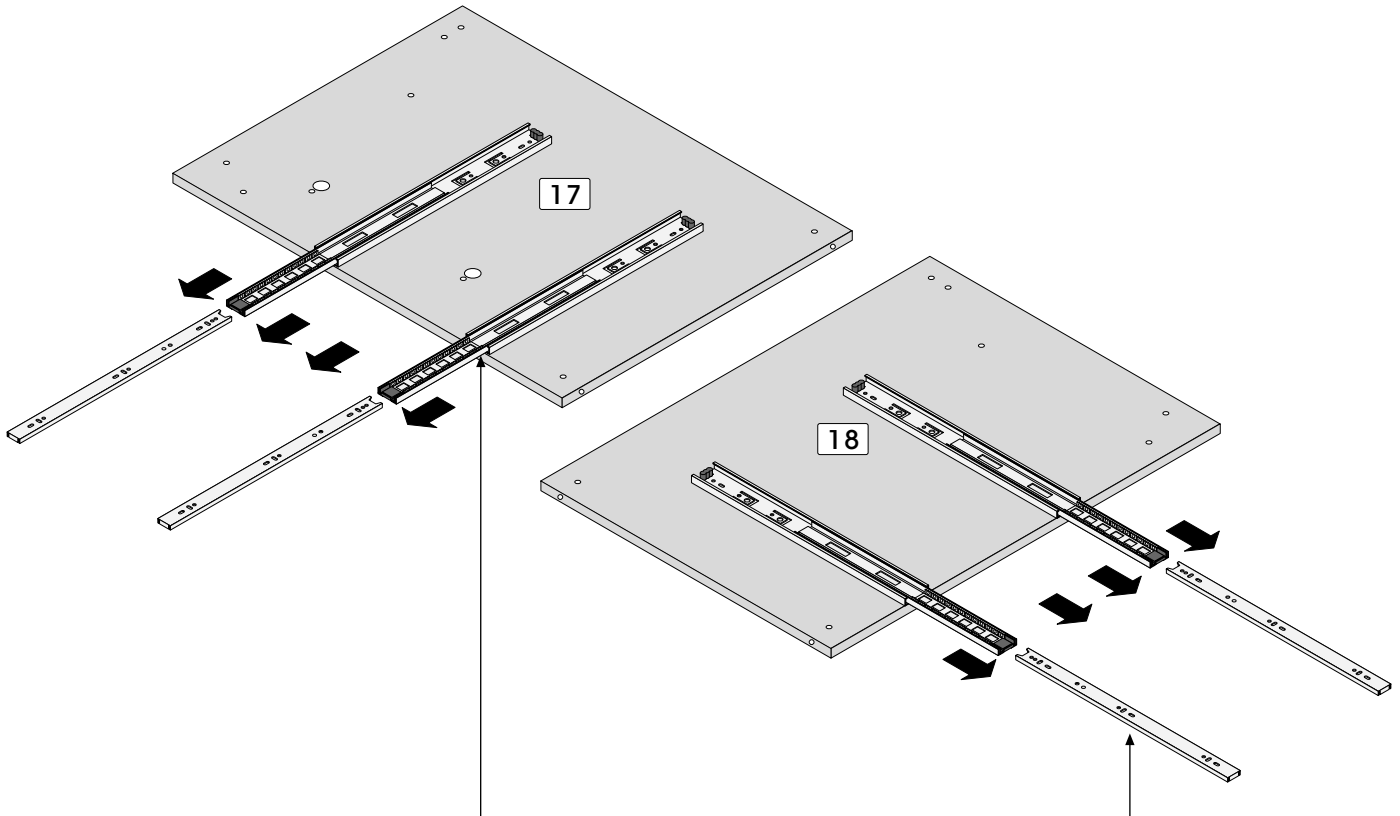

**1**

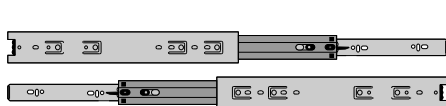

Code / Código

CO-249

Qty / Qté / Cant.

x 2



CR-141

x 2



VR-207

x 16



VE-244

x 12

**SERVICE/SERVICIO: 1-888 8BESTAR (1-888 823-7827)**

# 2 HARDWARE INSTALLATION / INSTALLATION DES QUINCAILLERIES / INSTALACIÓN DE LAS QUINCALLAS

Desk / Bureau / Escritorio

**Important/Importante**  
 Make sure to use the largest in runner holes (CO-762), as indicated below.  
 Assurez-vous d'utiliser les plus gros trous du coulisseau (CO-762), tel qu'indiqué ci-dessous.  
 Utilice los agujeros más grandes de la guía (CO-762), como se indica a continuación.

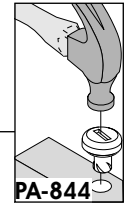
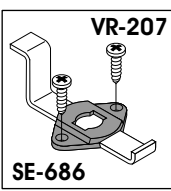
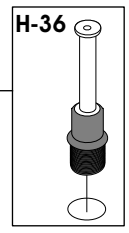
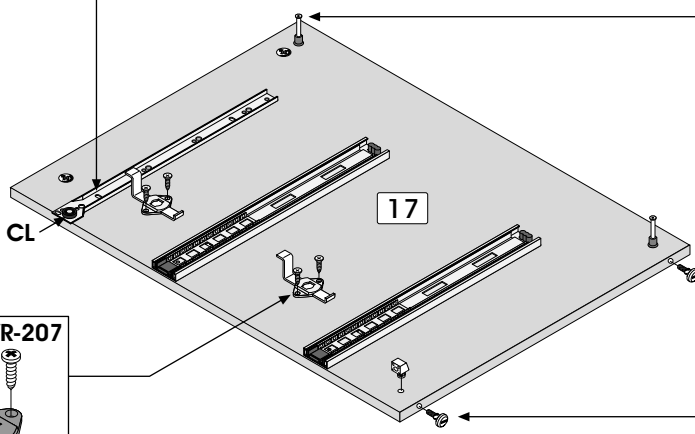
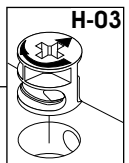
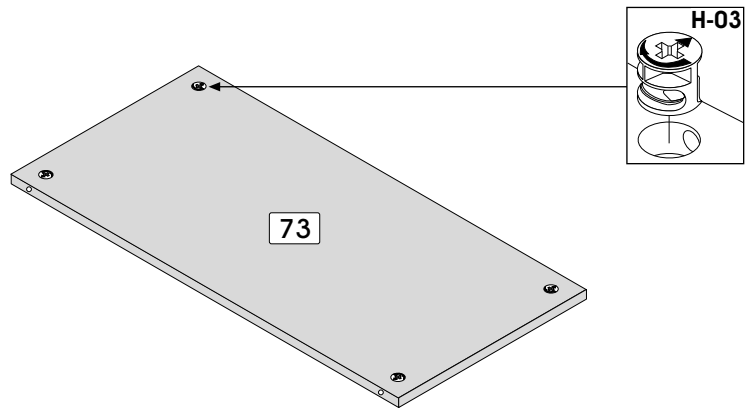
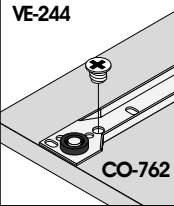

**insert**  
insérer  
insertar

**TI-552**  
 remove the screw to be used in step 3.  
 enlever la vis qui servira à l'étape 3.  
 sacar el tornillo que servirá para la etapa 3.

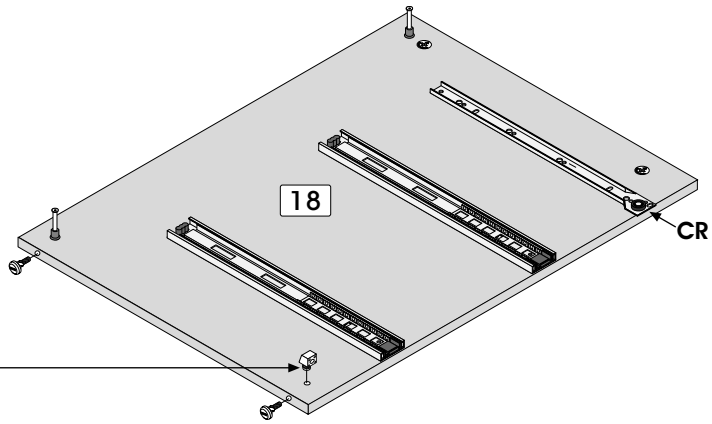

<b>2</b>								
<b>Code / Código</b>	CO-762	H-03	H-36	PA-844	VR-207	SE-686	TI-552	VE-244
<b>Qty / Qté / Cant.</b>	x 1	x 8	x 4	x 4	x 4	x 2	x 2	x 4

SERVICE/SERVICIO: 1-888 8BESTAR (1-888 823-7827)

# IMPORTANT NOTICE / NOTE IMPORTANTE / NOTA IMPORTANTE

## ▶ Main hardware system / Système de quincaillerie principal / Sistema principal de quincallas

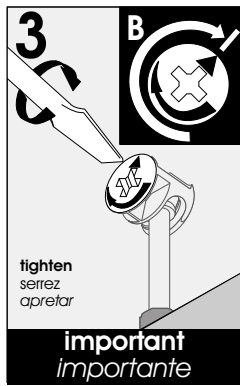
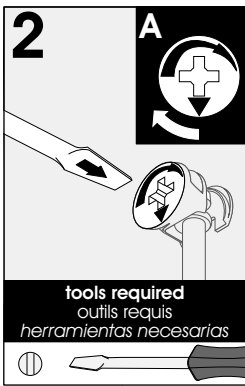
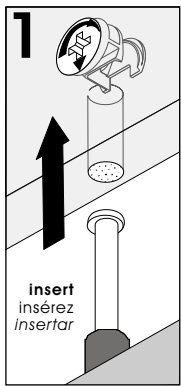

**Make sure to properly tighten each cam to ensure furniture solidity. Otherwise, parts could be damaged or the user could be injured.**

Assurez-vous de bien resserrer chaque rondelle pour assurer la solidité du meuble. Dans le cas contraire, des pièces pourraient être endommagées ou l'utilisateur pourrait se blesser.

Asegúrese de apretar bien cada arandela para garantizar la solidez del mueble. De lo contrario, podría provocarse daño a las piezas o las personas.

## 3 PRE-ASSEMBLY / PRÉ-ASSEMBLAGE / PREENSAMBLAJE

Desk / Bureau / Escritorio

### Assemble upside down

Assemblez en position renversée  
Realice el ensamble en posición invertida

### Assembling sequence

Séquence d'assemblage  
Secuencia de ensablaje

Parts / Pièces / Piezas:

**18 73 17 CA80B**

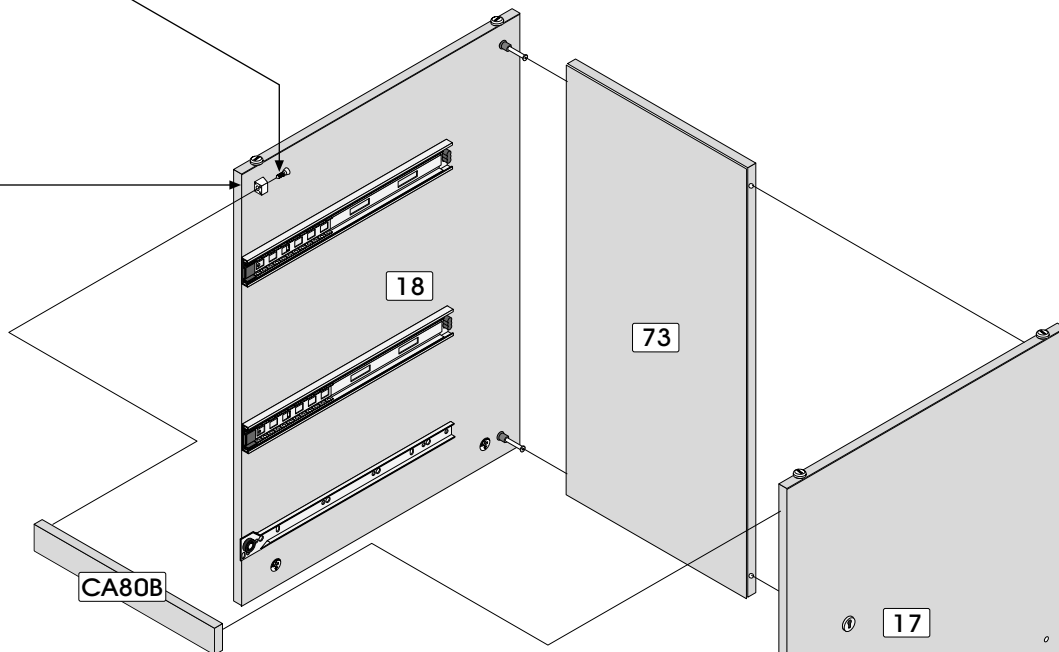
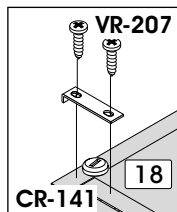
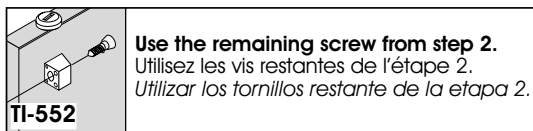

**3**

Code / Código	CR-141	VR-207
Qty / Qté / Cant.	x 1	x 2

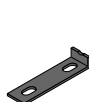

SERVICE/SERVICIO: 1-888 8BESTAR (1-888 823-7827)



**4** **HARDWARE INSTALLATION / INSTALLATION DES QUINCAILLERIES / INSTALACIÓN DE LAS QUINCALLAS**

Desk / Bureau / Escritorio

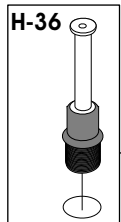
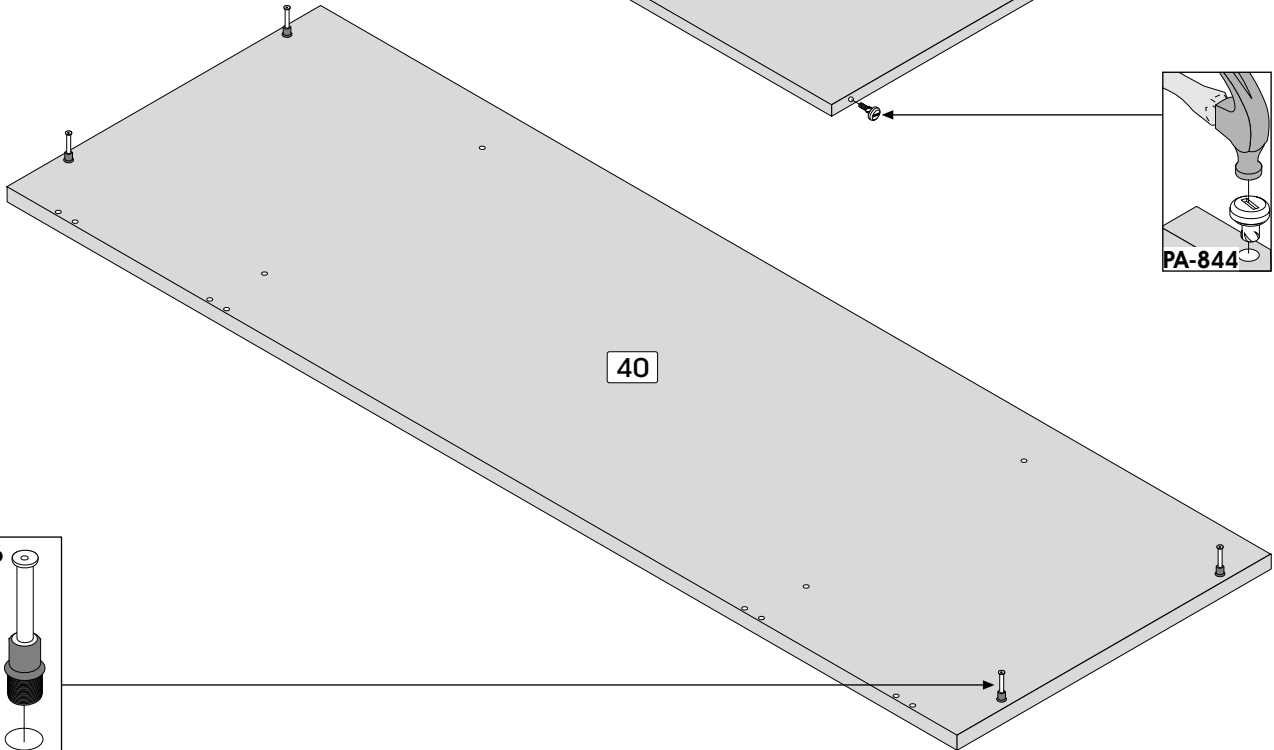
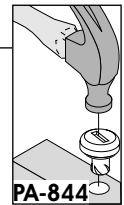
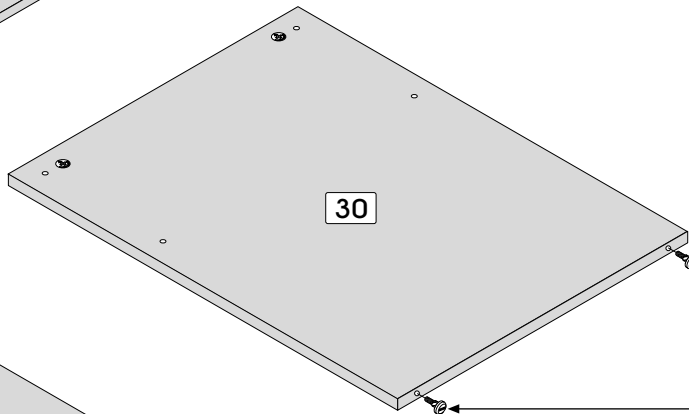
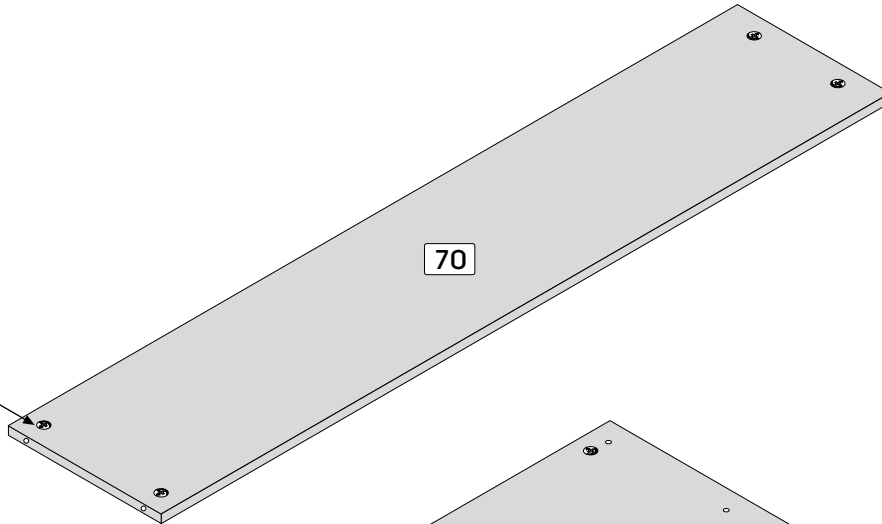
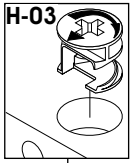

**4**

Code / Código

H-03

H-36

PA-844

Qty / Qté / Cant.

x 6

x 4

x 2

SERVICE/SERVICIO: 1-888 8BESTAR (1-888 823-7827)

Desk / Bureau / Escritorio

**Assemble upside down**

Assemblez en position renversée

Realice el ensamblaje en posición invertida

**Assembling sequence**

Séquence d'assemblage

Secuencia de ensamblaje

Parts / Pièces / Piezas:

18 17 + 70 30 40

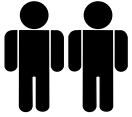
 **two people are required to assemble and move this model.**  
deux personnes sont requises pour assembler et déplacer ce modèle.  
se necesitan dos personas para ensamblar y desplazar este mueble.

**Left Assembly**  
Assemblage gauche  
Ensamblaje Izquierdo

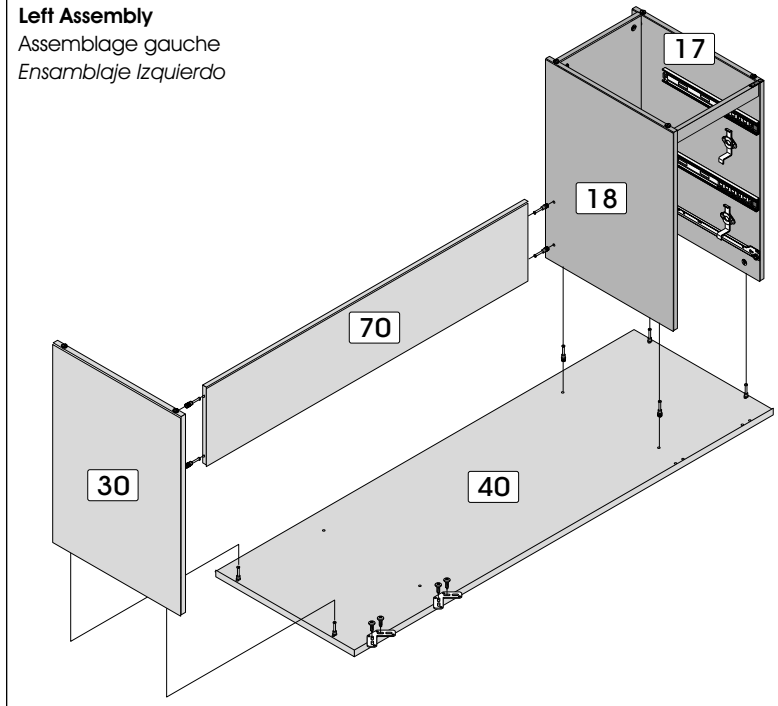

**important / importante**

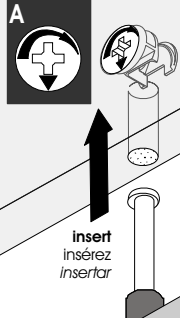
**A**  insert  
insérez  
insertar

**B**  tighten  
serrez  
apretar

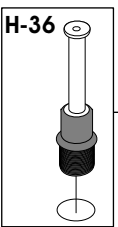
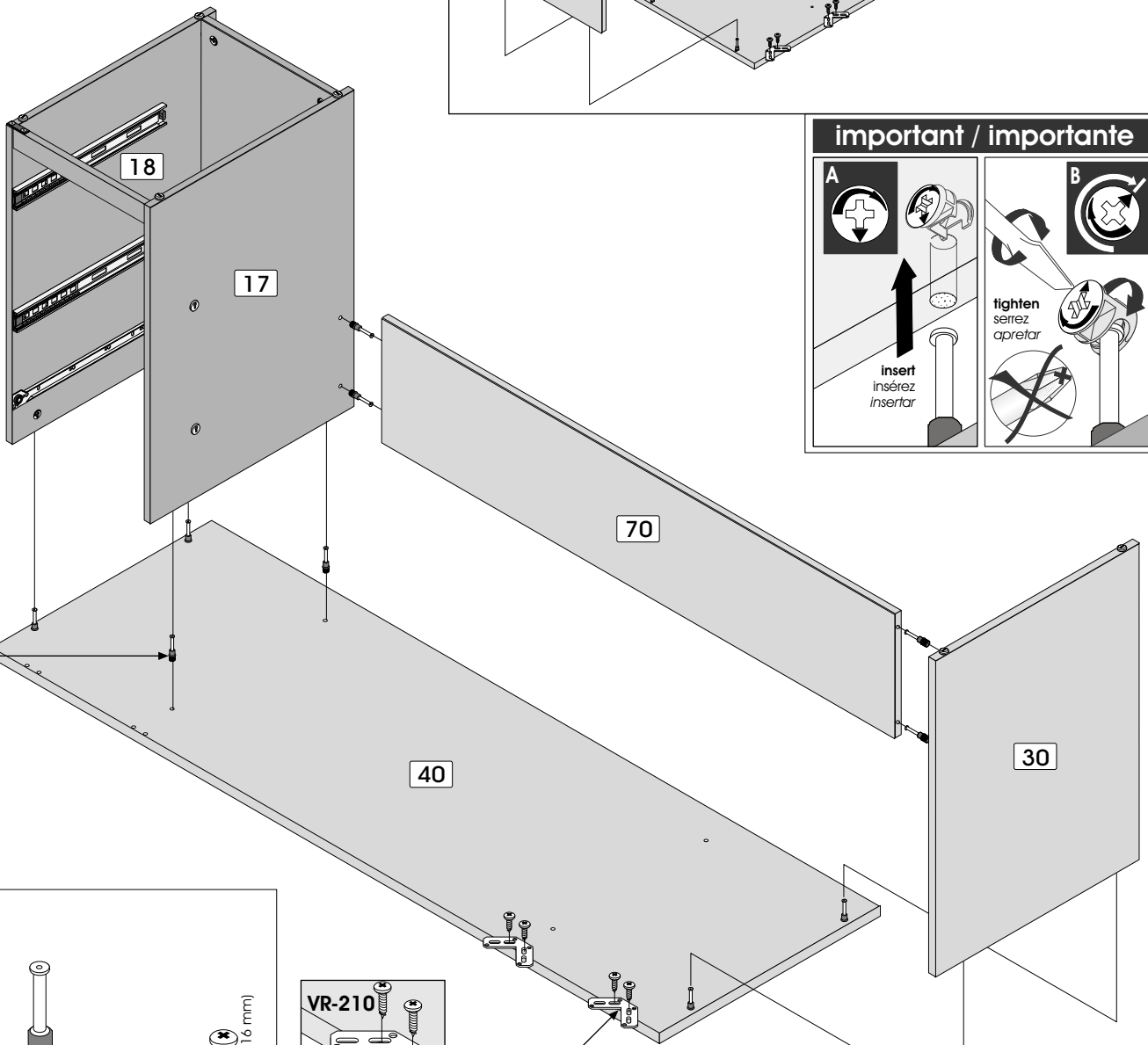

**5**

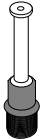
 **Code / Código** H-36  
**Qty / Qté / Cant.** x 6

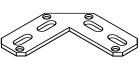
 **Code / Código** EQ-143  
**Qty / Qté / Cant.** x 2

 **Code / Código** VR-210  
**Qty / Qté / Cant.** x 4

5/8" (16 mm)

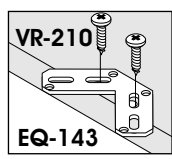

**Right Assembly**  
Assemblage droit  
Ensamblaje Derecho

Desk / Bureau / Escritorio

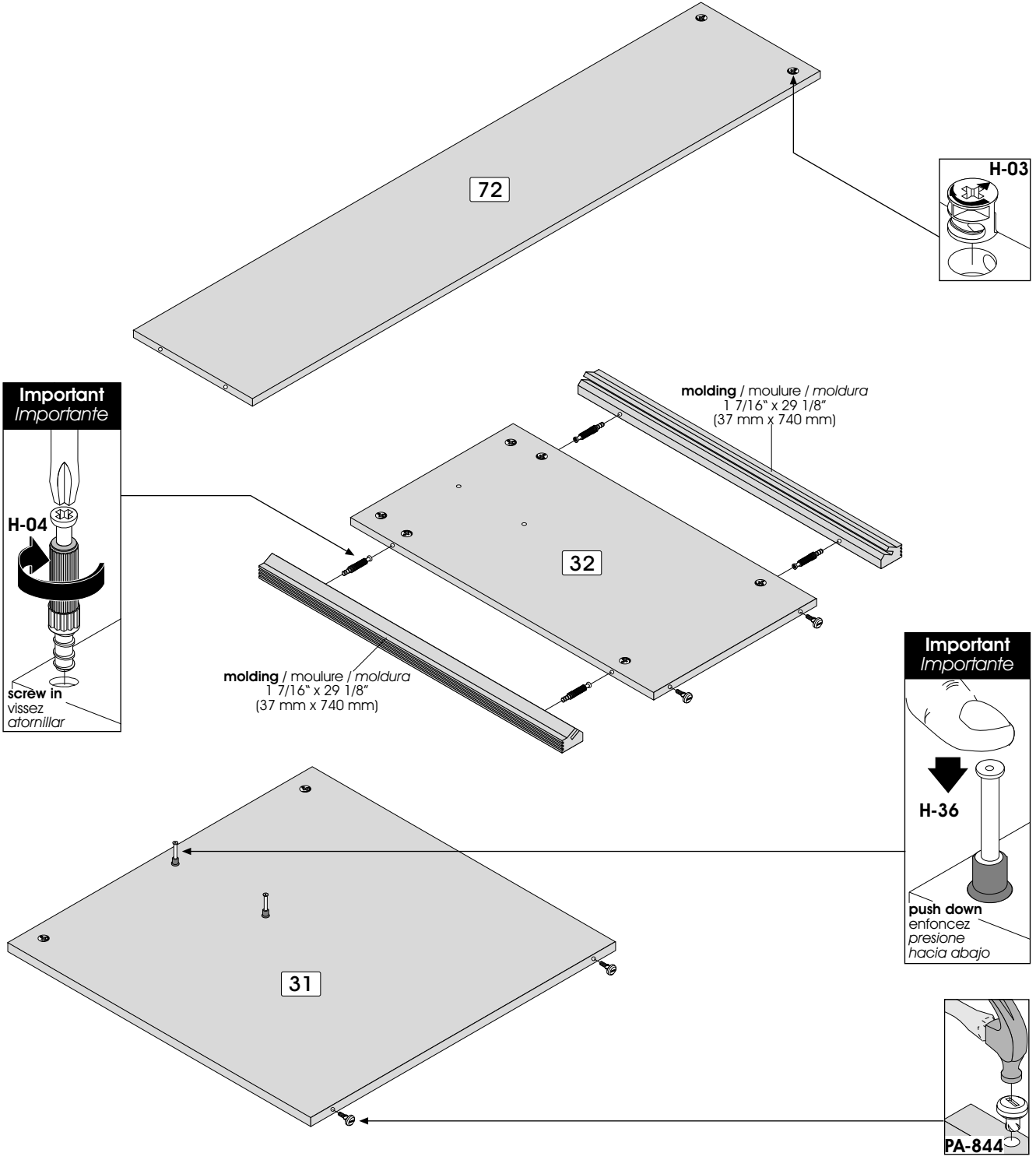

**Important**  
*Importante*

**H-04**

screw in  
vissez  
atornillar

**Important**  
*Importante*

**H-36**

push down  
enfoncez  
presione  
hacia abajo

**PA-844**

Code / Código	H-03	H-36	PA-844	H-04
Qty / Qté / Cant.	x 10	x 2	x 4	x 4

**7** PRE-ASSEMBLY / PRÉ-ASSEMBLAGE / PREENSAMBLAJE

Desk / Bureau / Escritorio

**Assemble upside down**

Assemblez en position renversée  
Realice el ensamblaje en posición invertida

**Assembling sequence**

Séquence d'assemblage  
Secuencia de ensamblaje

Parts / Pièces / Piezas:

**31** **72** **32**

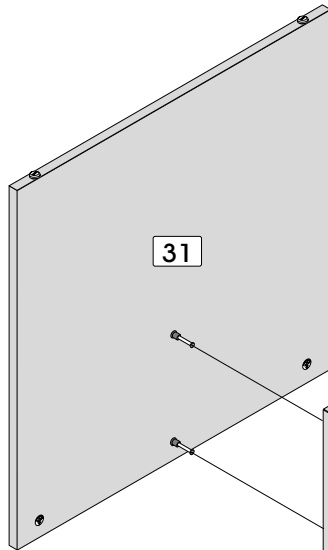

**Right Assembly**  
Assemblage droit  
Ensamblaje Derecho

**Left Assembly**  
Assemblage gauche  
Ensamblaje Izquierdo

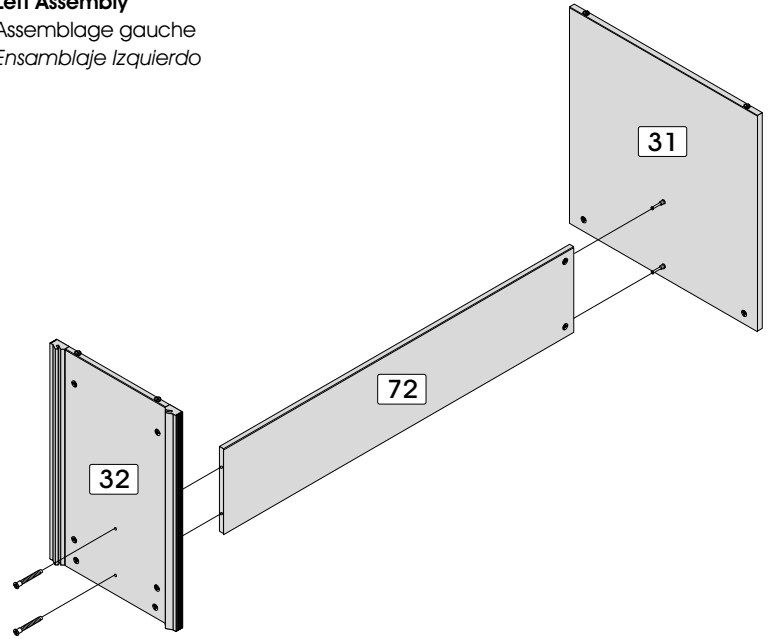

**two people are required to assemble and move this model.**

deux personnes sont requises pour assembler et déplacer ce modèle.  
se necesitan dos personas para ensamblar y desplazar este mueble.

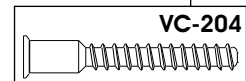
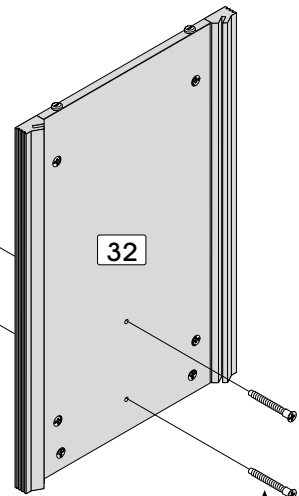
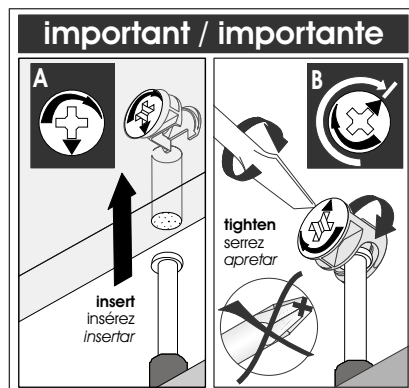

**7**

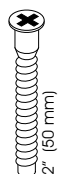

Code / Código VC-204  
Qty / Qté / Cant. x 2

SERVICE/SERVICIO: 1-888 8BESTAR (1-888 823-7827)

Desk / Bureau / Escritorio

**important / importante**

**Drive the screw all the way in to install CO-843.**

Vissez à fond avant d'installer la CO-843.

Atornille a fondo antes de instalar el CO-843.

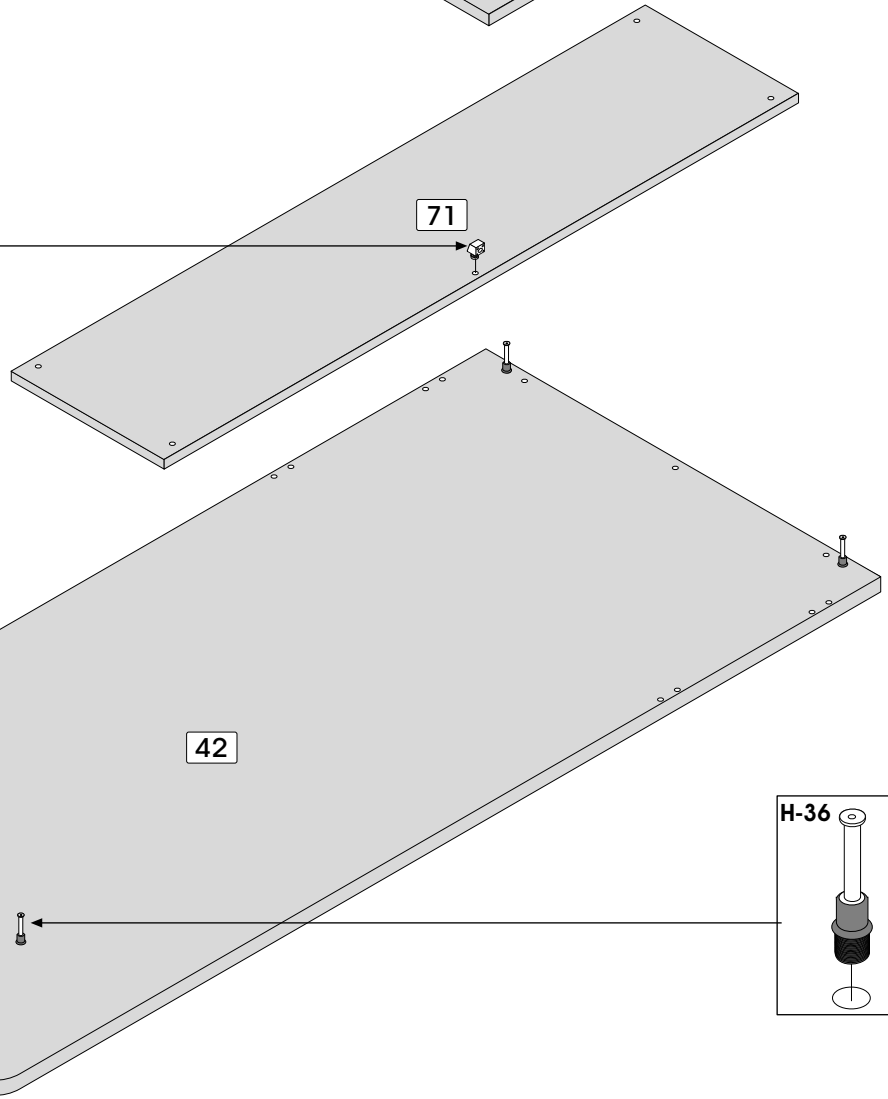
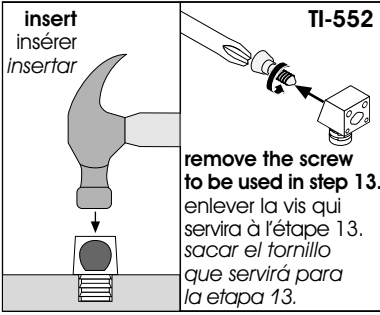
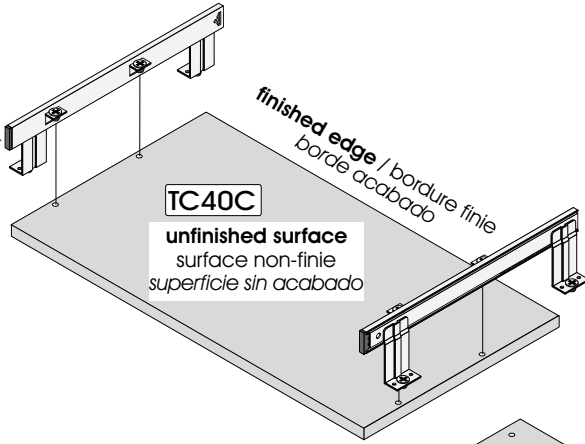
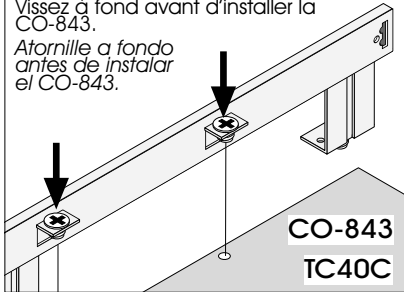

Code / Código

Qty / Qté / Cant.

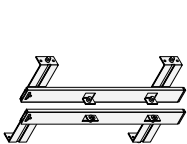

CO-843

x 1

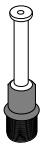

H-36

x 4



TI-552

x 1

Desk / Bureau / Escritorio

**Assemble on the side**

Assemblez sur le côté

Realice el ensamblaje sobre la parte lateral

**Assembling sequence**

Séquence d'assemblage

Secuencia de ensamblaje

Parts / Pièces / Piezas:

84 42 + 32 31

 **two people are required to assemble and move this model.**  
 deux personnes sont requises pour assembler et déplacer ce modèle.  
 se necesitan dos personas para ensamblar y desplazar este mueble.

**Left Assembly**  
Assemblage gauche  
Ensamblaje Izquierdo

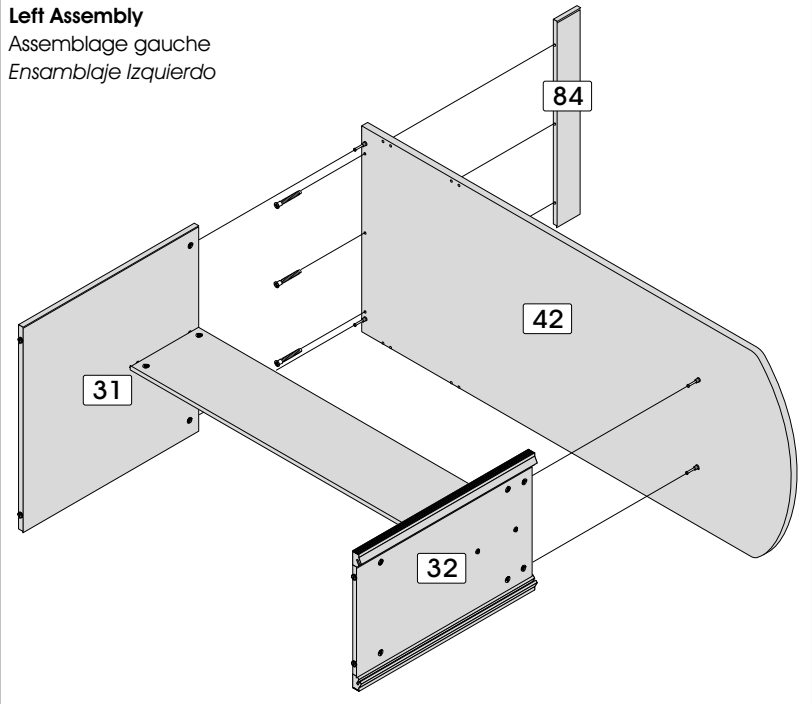

**Right Assembly**  
Assemblage droit  
Ensamblaje Derecho

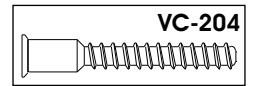
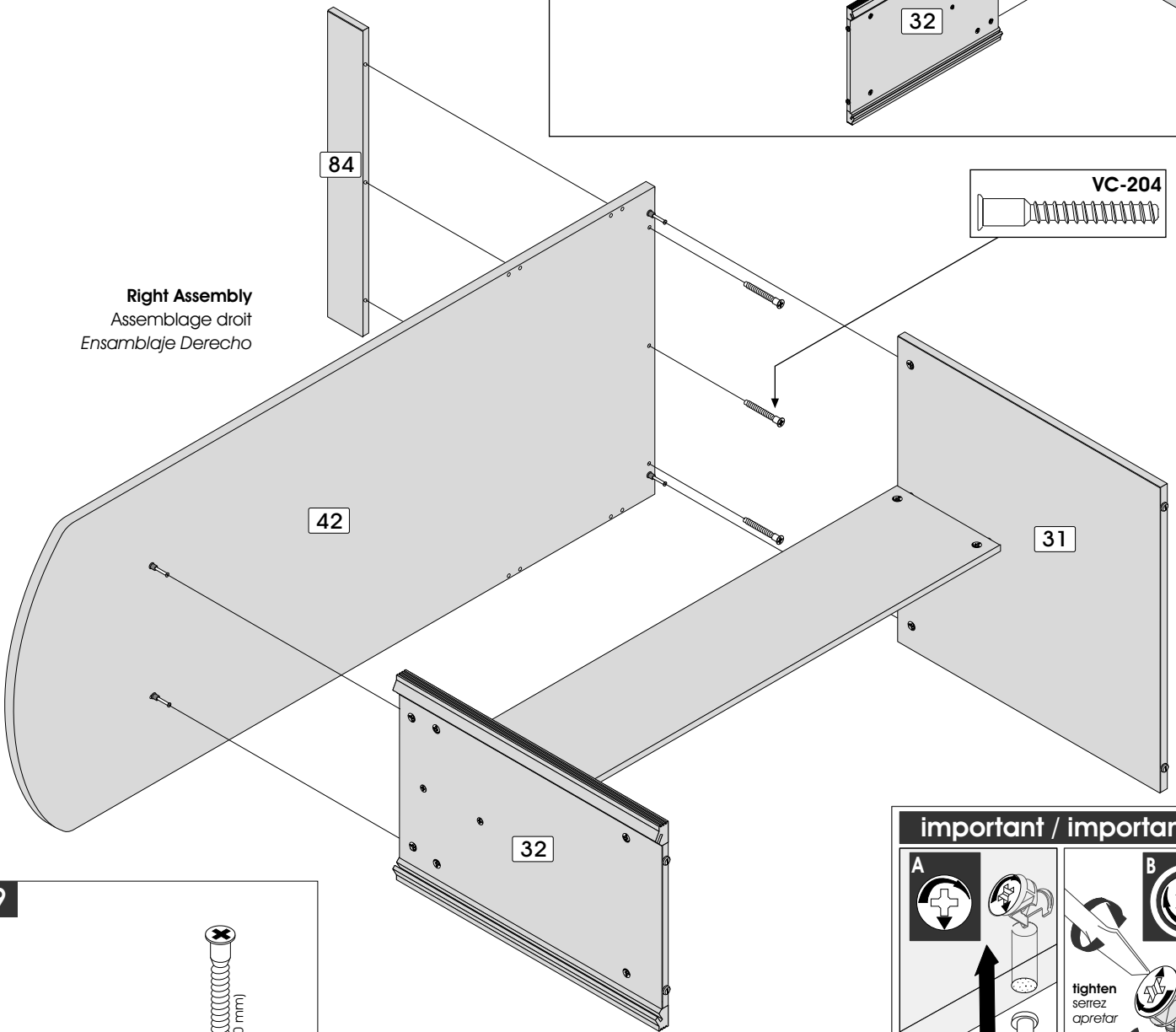

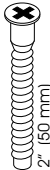

**9**



Code / Código VC-204  
Qty / Qté / Cant. x 3

**important / importante**

**A**  **insert / insérez / insertar**

**B**  **tighten / serrez / apretar**

# 10 INSTALLATION / INSTALLATION / INSTALACIÓN

Desk / Bureau / Escritorio

## Assemble on the side

Assemblez sur le côté

Realice el ensamblaje sobre la parte lateral

## Assembling sequence

Séquence d'assemblage

Secuencia de ensamblaje

Parts / Pièces / Piezas:

32 + panel / panneau / panel

### Left Assembly

Assemblage gauche

Ensamblaje Izquierdo

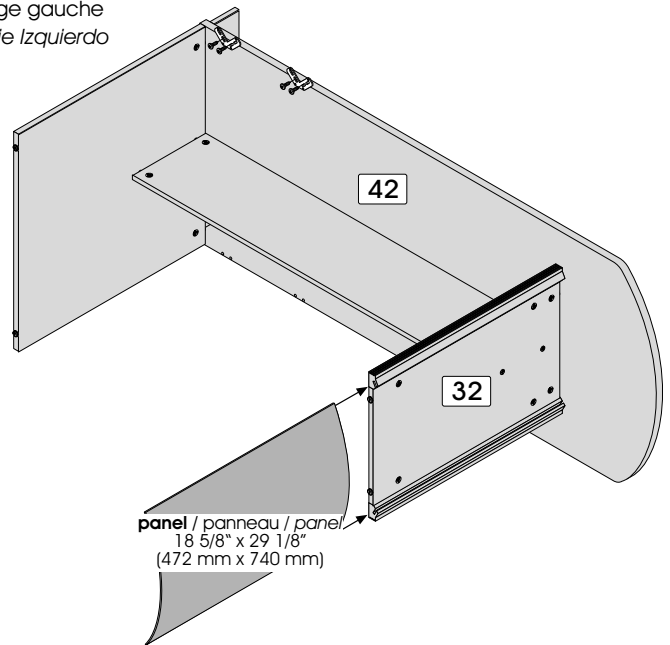

### Right Assembly

Assemblage droit

Ensamblaje Derecho

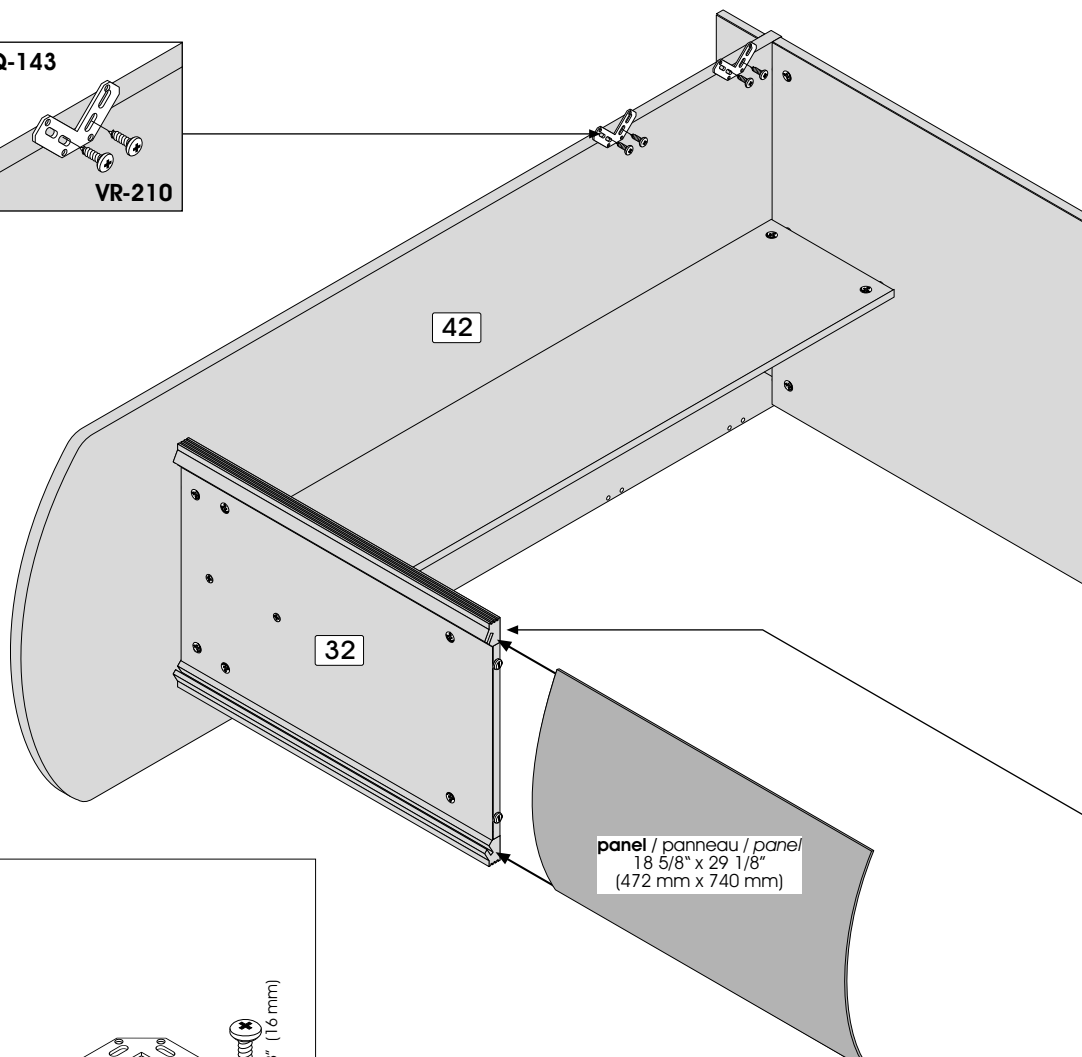
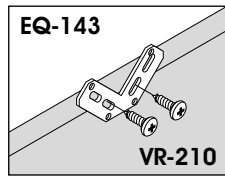

10

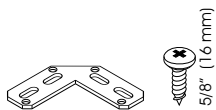

Code / Código	EQ-143	VR-210
Qty / Qté / Cant.	x 2	x 4

# 11 PRE-ASSEMBLY / PRÉ-ASSEMBLAGE / PREENSAMBLAJE

Desk / Bureau / Escritorio

## Assemble on the back edge

Assemblez sur la bordure arrière  
Realice el ensamblaje sobre el borde trasero

## Assembling sequence

Séquence d'assemblage  
Secuencia de ensamblaje

Parts / Pièces / Piezas:

41 83

Left Assembly  
Assemblage gauche  
Ensamblaje Izquierdo

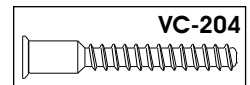
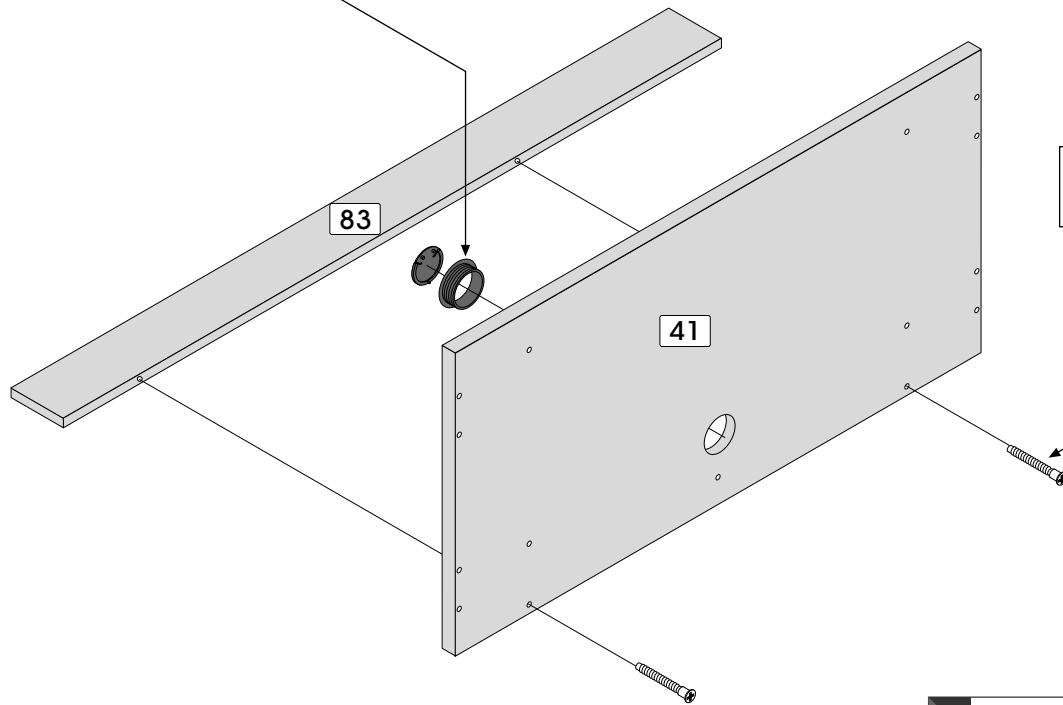
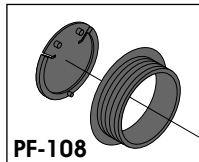
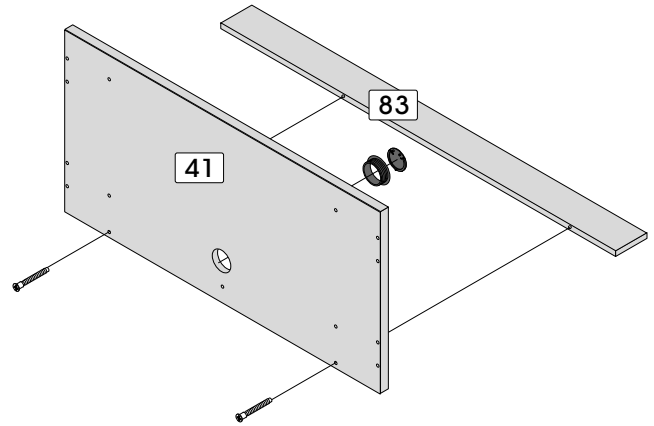

Right Assembly  
Assemblage droit  
Ensamblaje Derecho

11

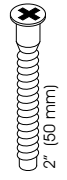
		
Code / Código	PF-108	VC-204
Qty / Qté / Cant.	x 1	x 2

SERVICE/SERVICIO: 1-888 8BESTAR (1-888 823-7827)



# 12 PRE-ASSEMBLY / PRÉ-ASSEMBLAGE / PREENSAMBLAJE

Desk / Bureau / Escritorio

## Assembling sequence

Séquence d'assemblage

Secuencia de ensamblaje

Parts / Pièces / Piezas:

42 40 + 41

**Left Assembly**  
Assemblage gauche  
Ensamblaje Izquierdo

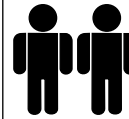
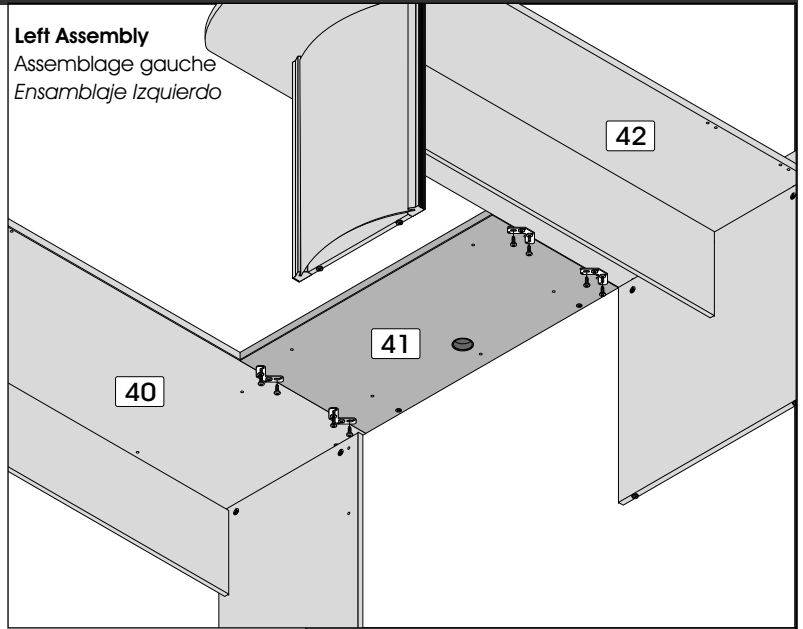

**two people are required to assemble and move this model.**

deux personnes sont requises pour assembler et déplacer ce modèle.  
se necesitan dos personas para ensamblar y desplazar este mueble.

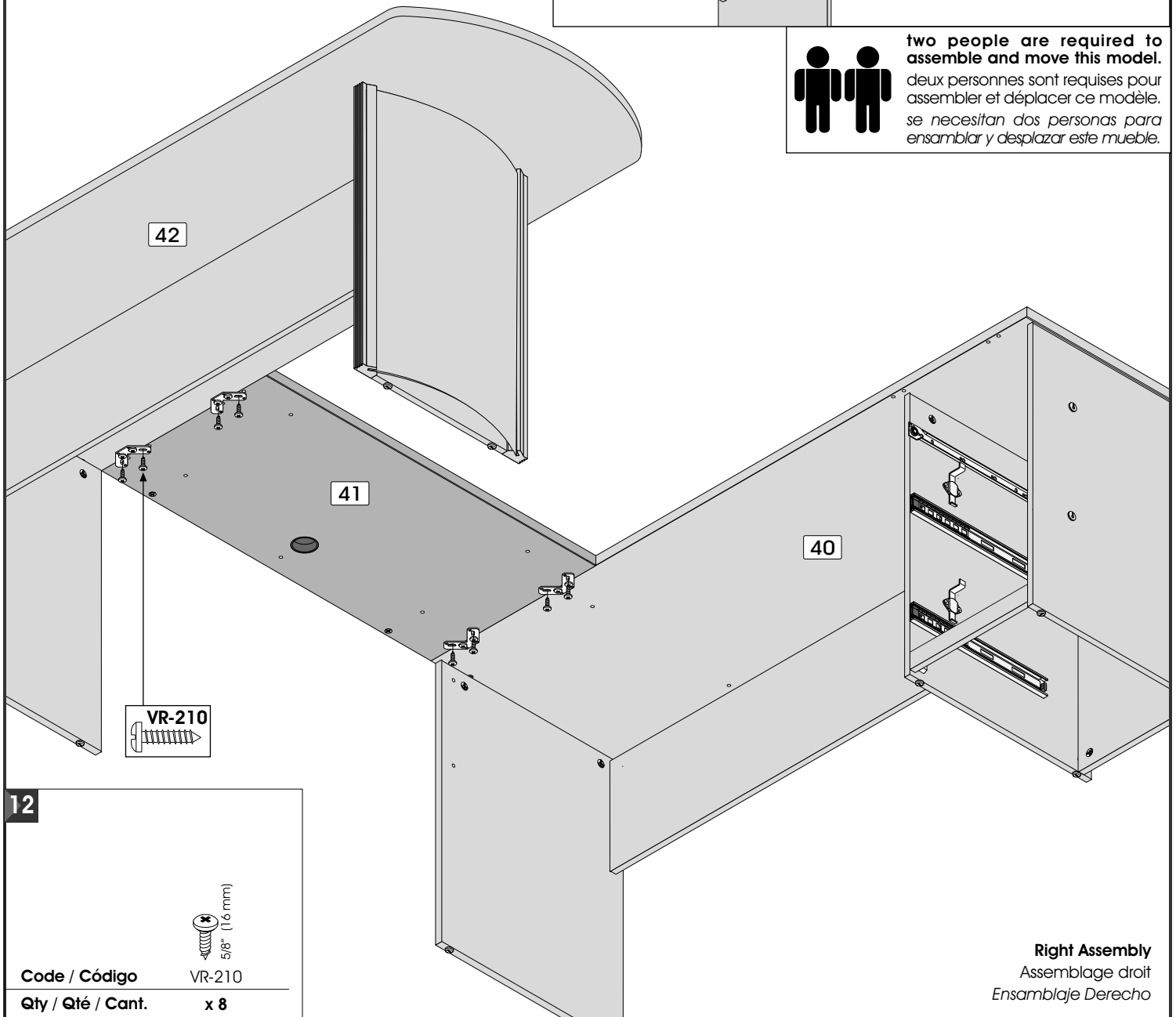

12

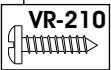

Code / Código

VR-210

Qty / Qté / Cant.

x 8

**Right Assembly**  
Assemblage droit  
Ensamblaje Derecho

SERVICE/SERVICIO: 1-888 8BESTAR (1-888 823-7827)

# 13 PRE-ASSEMBLY / PRÉ-ASSEMBLAGE / PREENSAMBLAJE

Desk / Bureau / Escritorio

## Assembling sequence

Séquence d'assemblage

Secuencia de ensamblaje

Parts / Pièces / Piezas:

**31 41 30** + **71**

**Left Assembly**  
Assemblage gauche  
Ensamblaje izquierdo

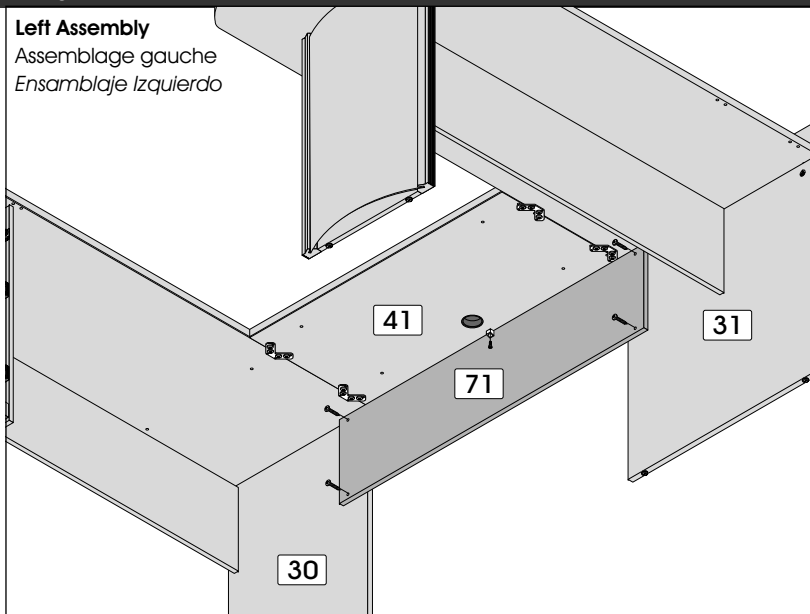

**two people are required to assemble and move this model.**

deux personnes sont requises pour assembler et déplacer ce modèle.  
se necesitan dos personas para ensamblar y desplazar este mueble.



**VR-212**  
without pre-drilled hole  
sans pré-perçage  
sin perforación previa

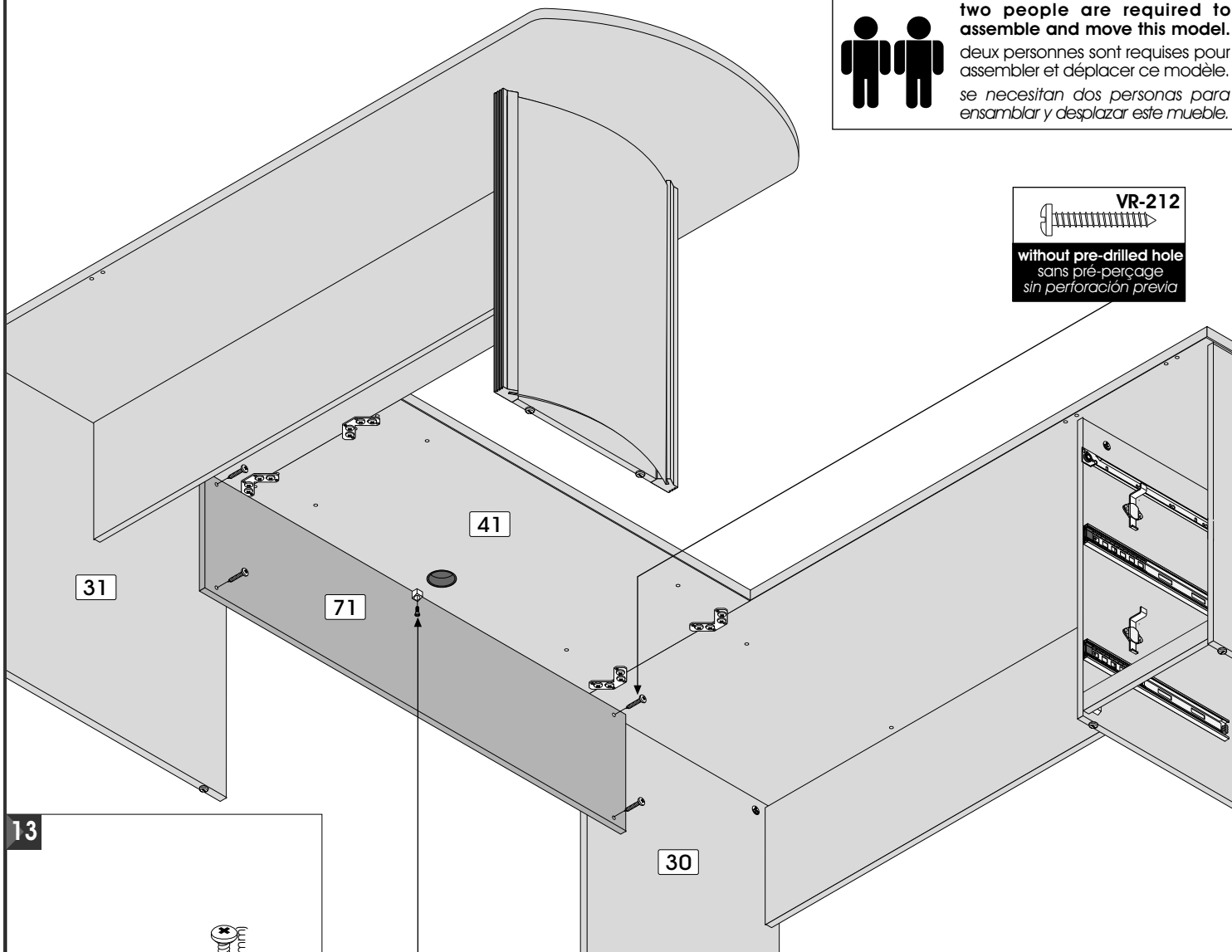

13



Code / Código VR-212  
Qty / Qté / Cant. x 4



**TI-552**  
Use the remaining screw from step 8.  
Utilisez les vis restantes de l'étape 8.  
Utilizar los tornillos restante de la etapa 8.

**Right Assembly**  
Assemblage droit  
Ensamblaje Derecho

SERVICE/SERVICIO: 1-888 8BESTAR (1-888 823-7827)

# 14 INSTALLATION / INSTALLATION / INSTALACIÓN

Keyboard Shelf / Tablette clavier / Estante para teclado

**Left Assembly**  
Assemblage gauche  
Ensamblaje Izquierdo

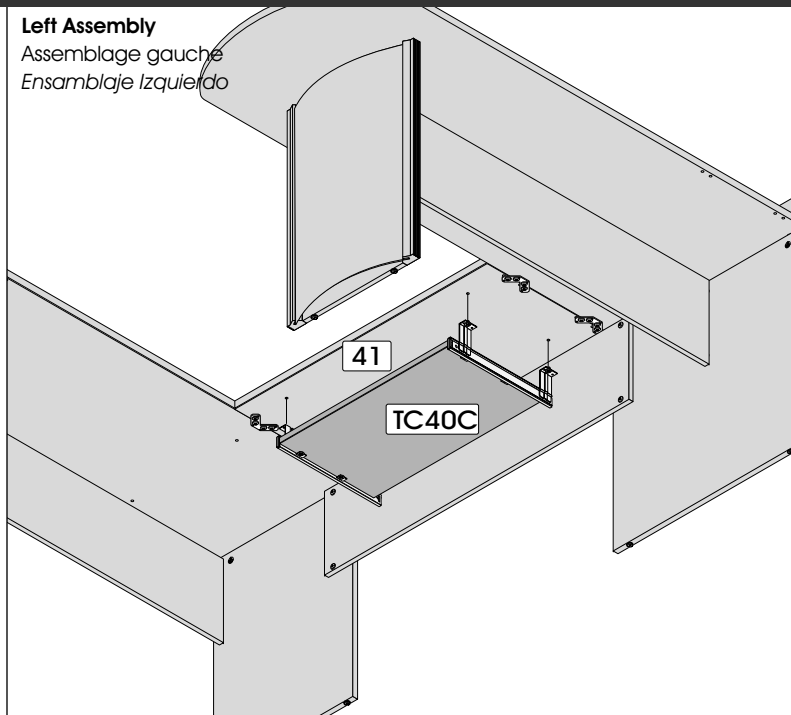

## important / importante



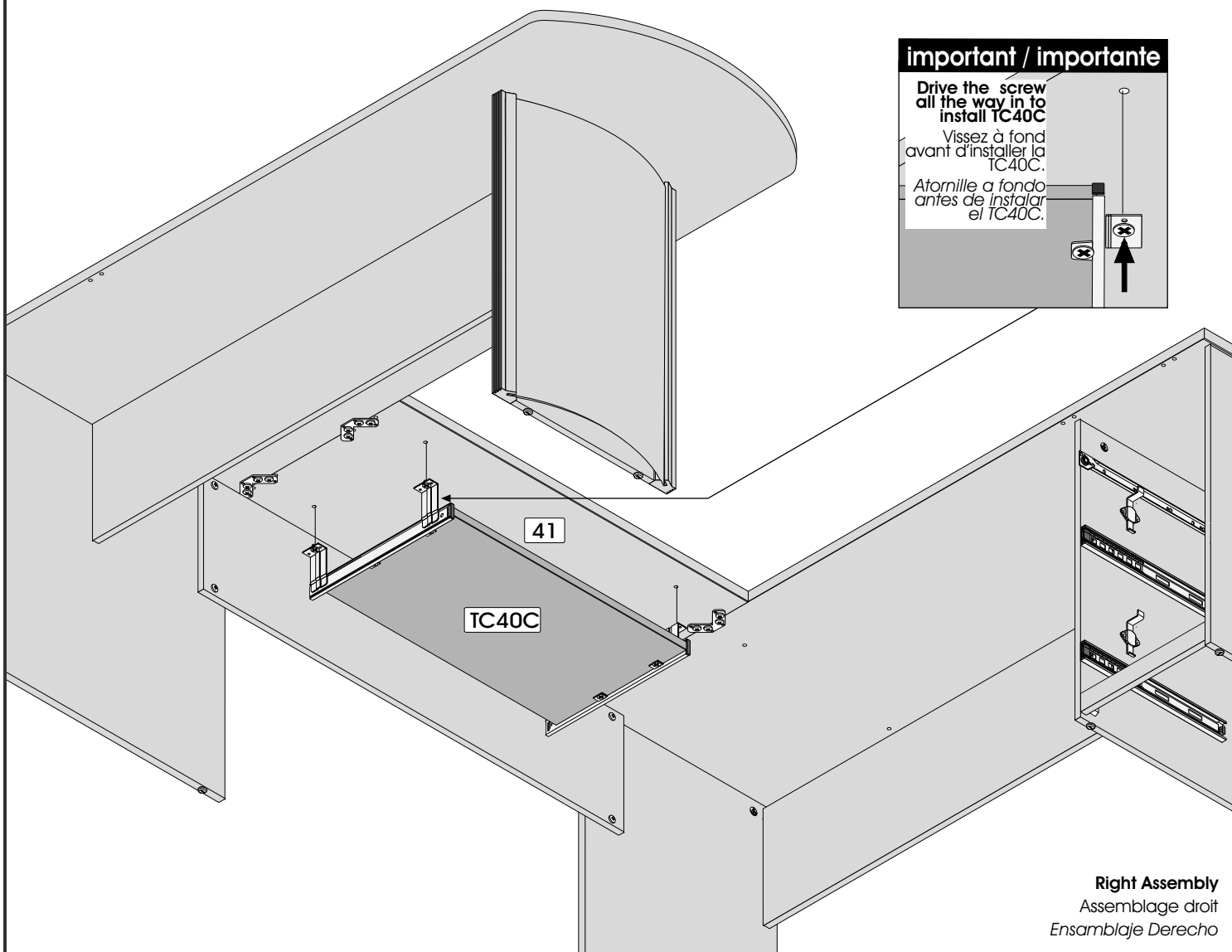
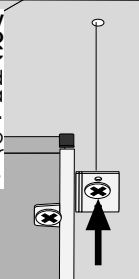

Drive the screw  
all the way in to  
install TC40C  
Vissez à fond  
avant d'installer la  
TC40C.  
Atornille a fondo  
antes de instalar  
el TC40C.

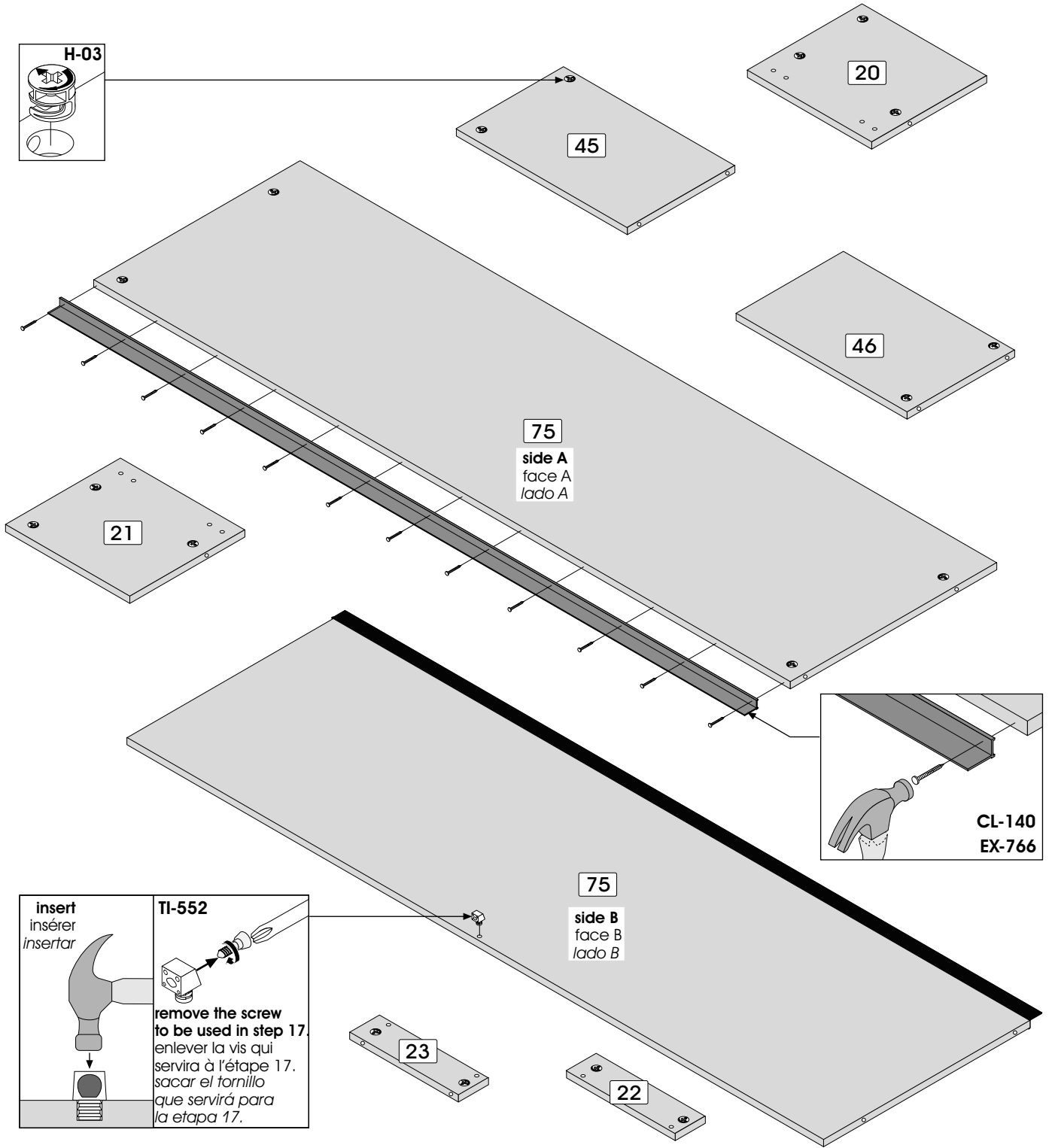

**Right Assembly**  
Assemblage droit  
Ensamblaje Derecho

**HUTCH / ÉTAGÈRE / ESTANERÍA**



<b>Code / Código</b>	 H-03	 TI-552	 EX-766	 CL-140
<b>Qty / Qté / Cant.</b>	x 18	x 1	x 1	x 12

HUTCH / ÉTAGÈRE / ESTANTERÍA

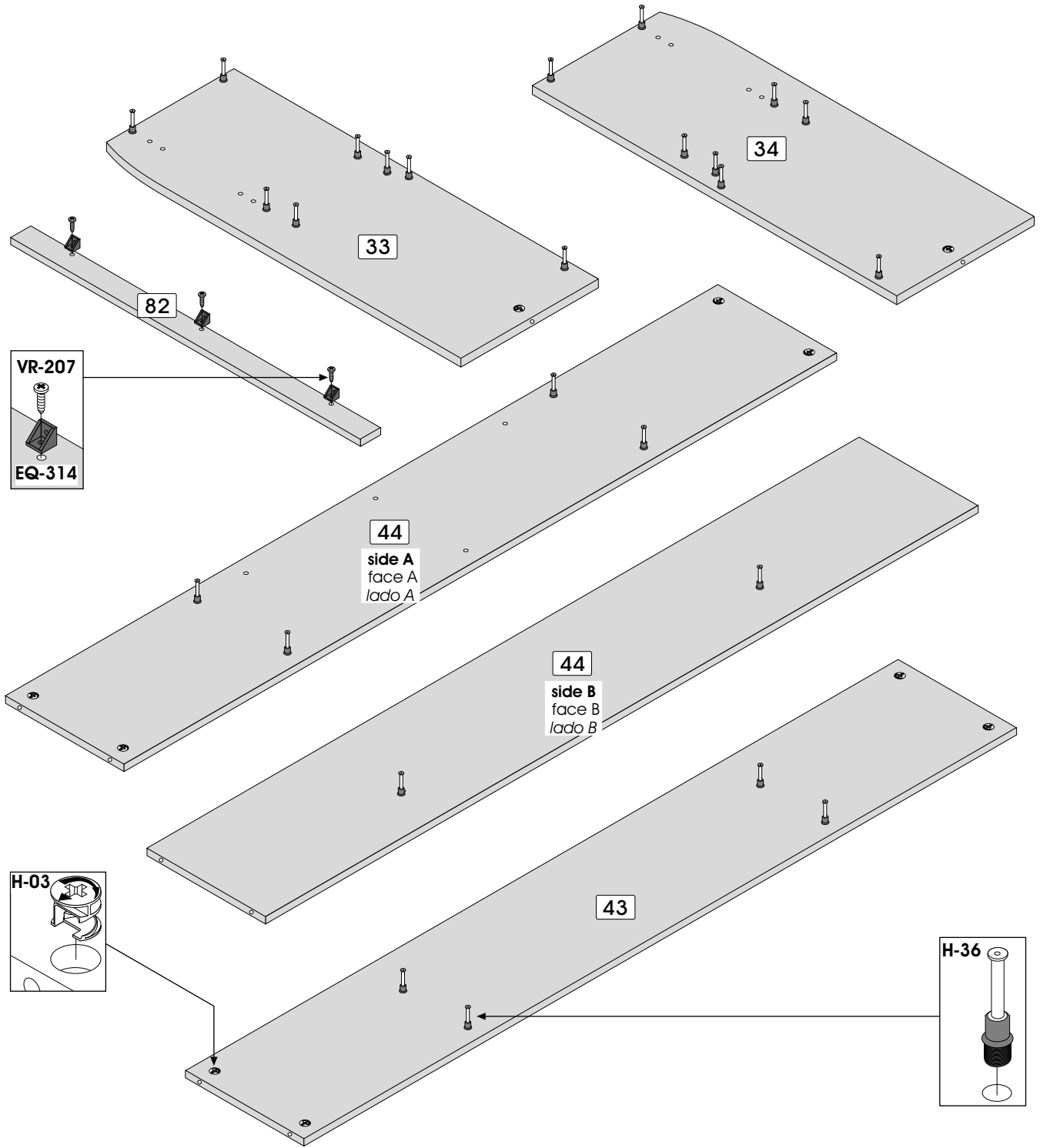

Code / Código	H-03	H-36	EQ-314	VR-207
Qty / Qté / Cant.	x 10	x 26	x 3	x 3

**Assemble on the back edge**

Assemblez sur la bordure arrière

Realice el ensamblaje sobre el borde trasero

**Assembling sequence**

Séquence d'assemblage

Secuencia de ensamblaje

Parts / Pièces / Piezas:

75 44 20 21 43



**two people are required to assemble and move this model.**  
deux personnes sont requises pour assembler et déplacer ce modèle.  
se necesitan dos personas para ensamblar y desplazar este mueble.

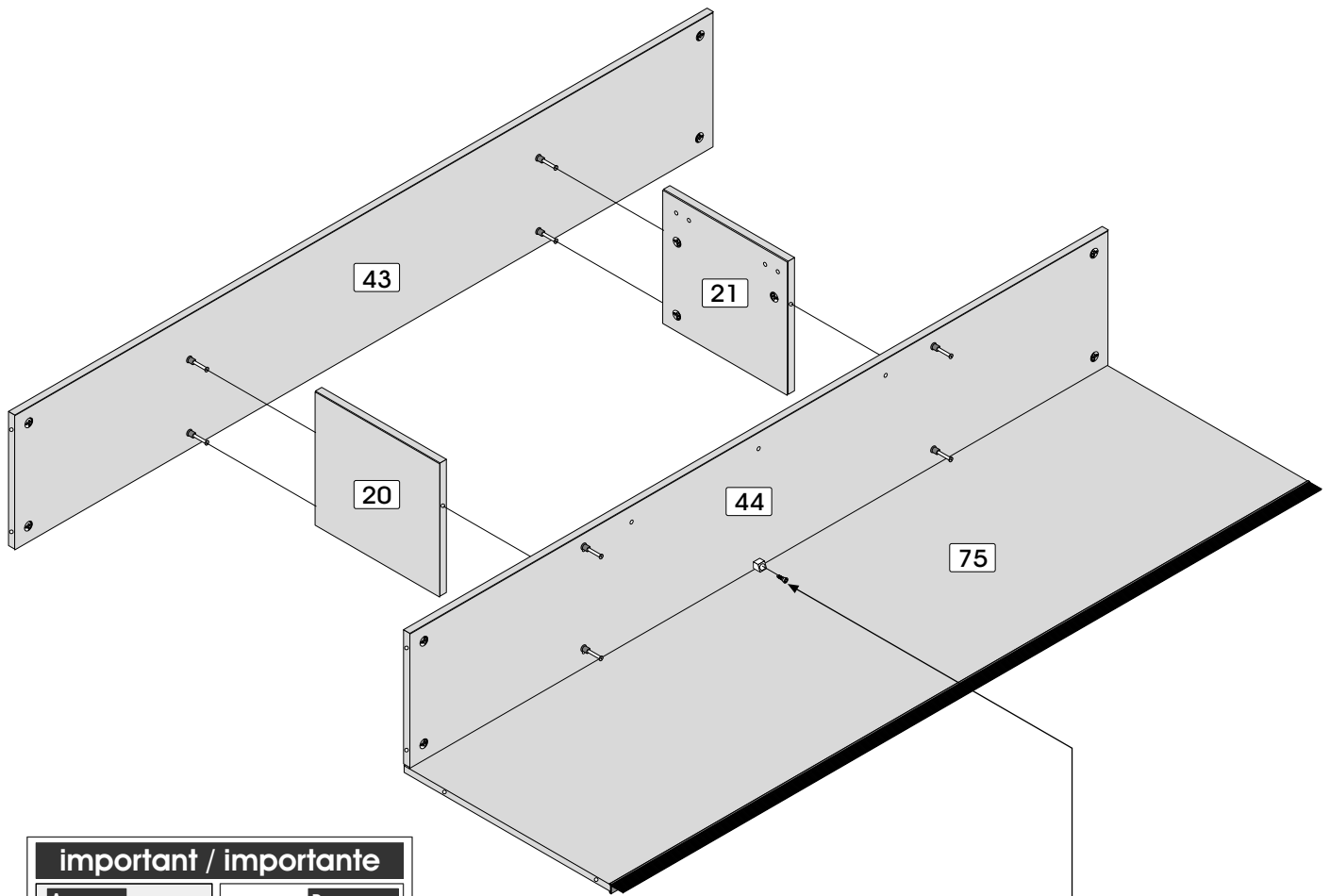

**important / importante**

**A**

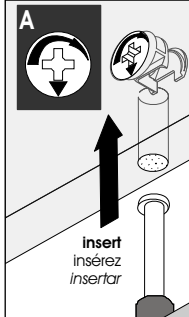

↑  
insert  
insérez  
insertar

**B**



tighten  
serrez  
apretar

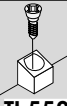

**TI-552**

**Use the remaining screw from step 15.**  
Utilisez les vis restantes de l'étape 15.  
Utilizar los tornillos restante de la etapa 15.

**Assemble on the back edge**

Assemblez sur la bordure arrière

Realice el ensamble sobre el borde trasero

**Assembling sequence**

Séquence d'assemblage

Secuencia de ensamblaje

Parts / Pièces / Piezas:

- 34 + 43 44 75 + 33 + 45 46 22 23 82

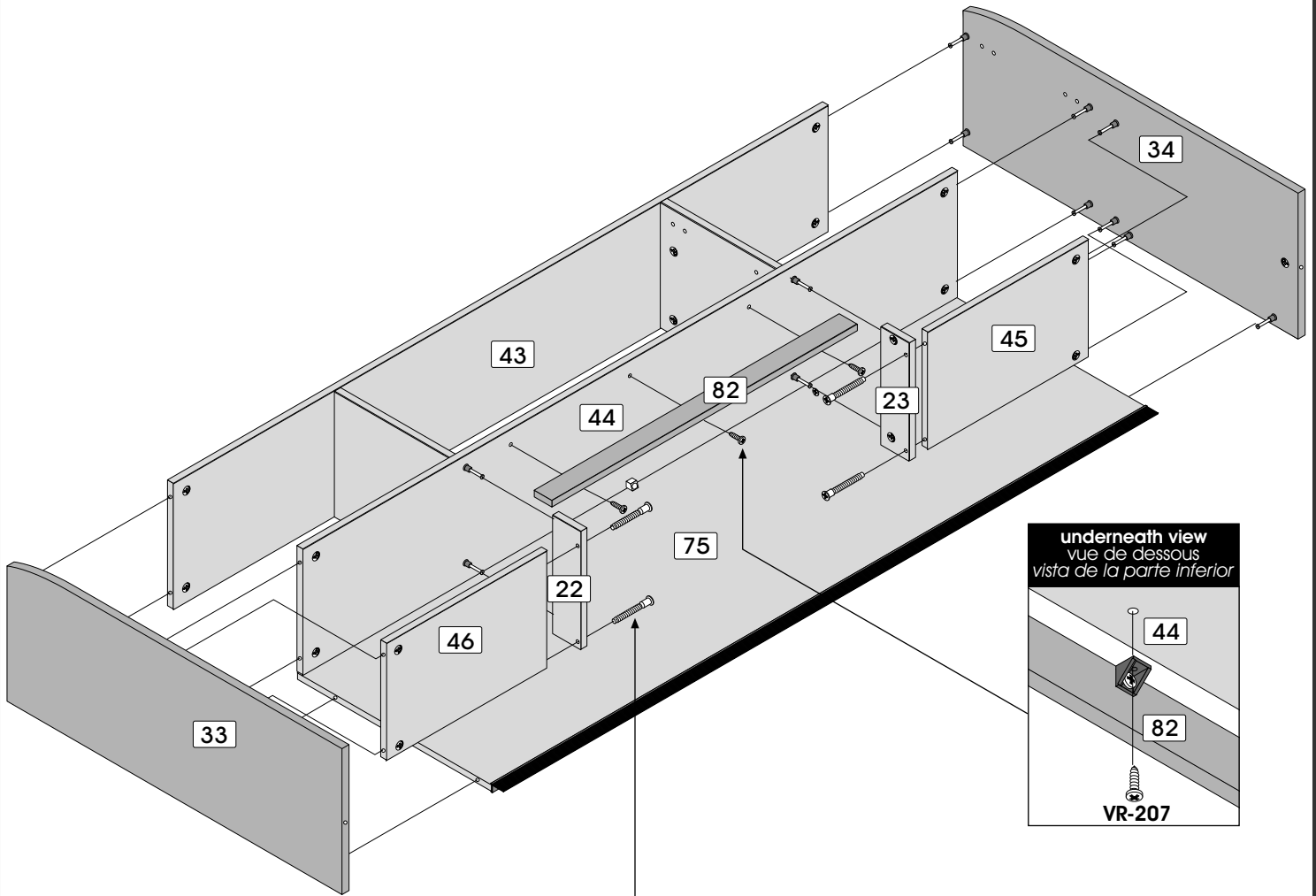
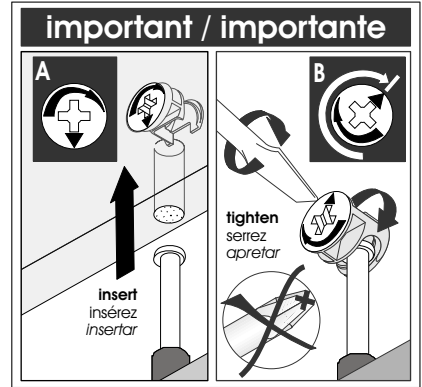

**two people are required to assemble and move this model.**  
 deux personnes sont requises pour assembler et déplacer ce modèle.  
 se necesitan dos personas para ensamblar y desplazar este mueble.

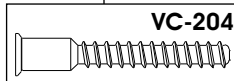

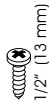
<b>18</b>	
	 1/2" (13 mm)
<b>Code / Código</b>	VR-207
<b>Qty / Qté / Cant.</b>	x 3

**Important/Importante**

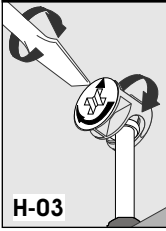

**Remember to tighten the H-03 located on the back panel.**  
 N'oubliez pas de serrer les H-03 qui sont situées au dos.  
 No se olvide de apretar las H-03 que se encuentran en el panel trasero.



**two people are required to assemble and move this model.**  
 deux personnes sont requises pour assembler et déplacer ce modèle.  
 se necesitan dos personas para ensamblar y desplazar este mueble.

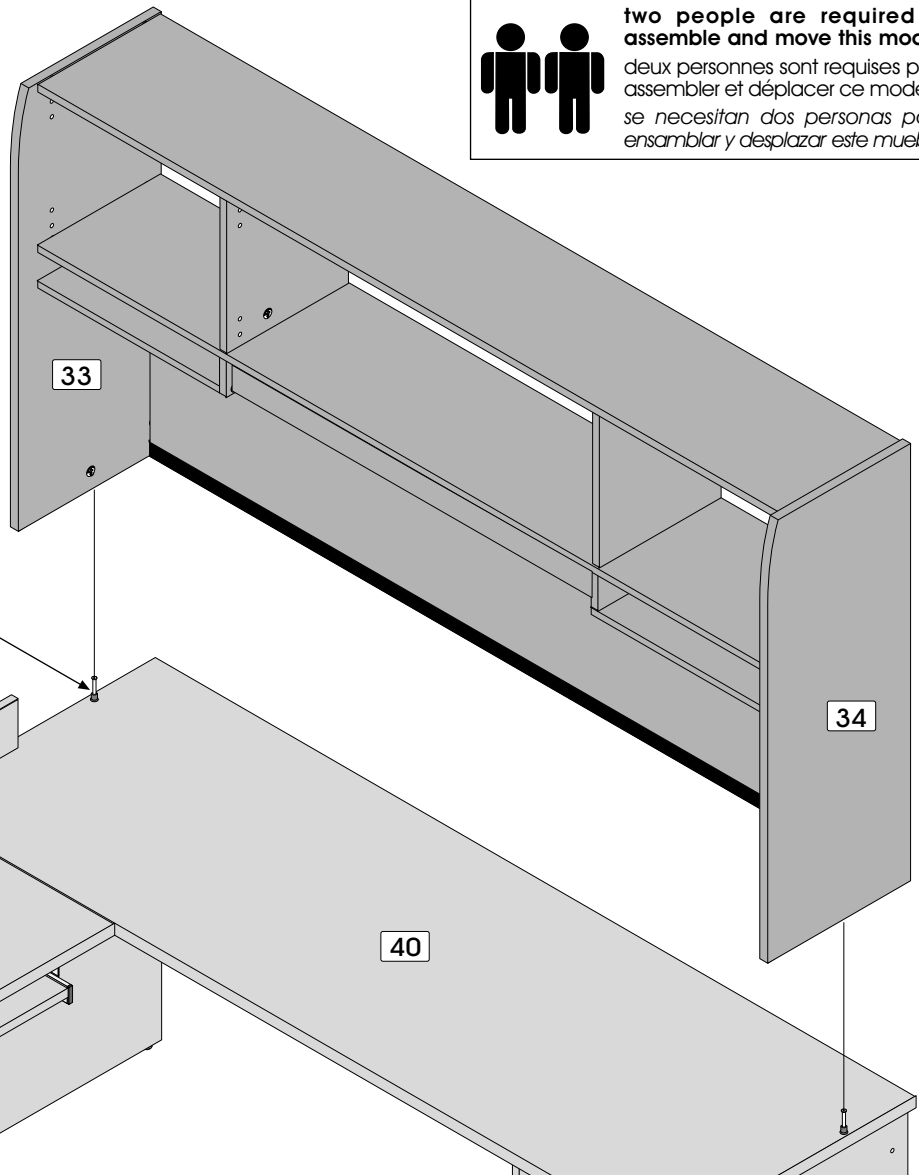
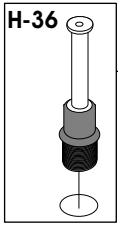

**Right Assembly**  
 Assemblage droit  
 Ensamblaje Derecho

19

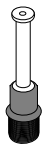

**Code / Código** H-36  
**Qty / Qté / Cant.** x 2

**Left Assembly**  
 Assemblage gauche  
 Ensamblaje Izquierdo

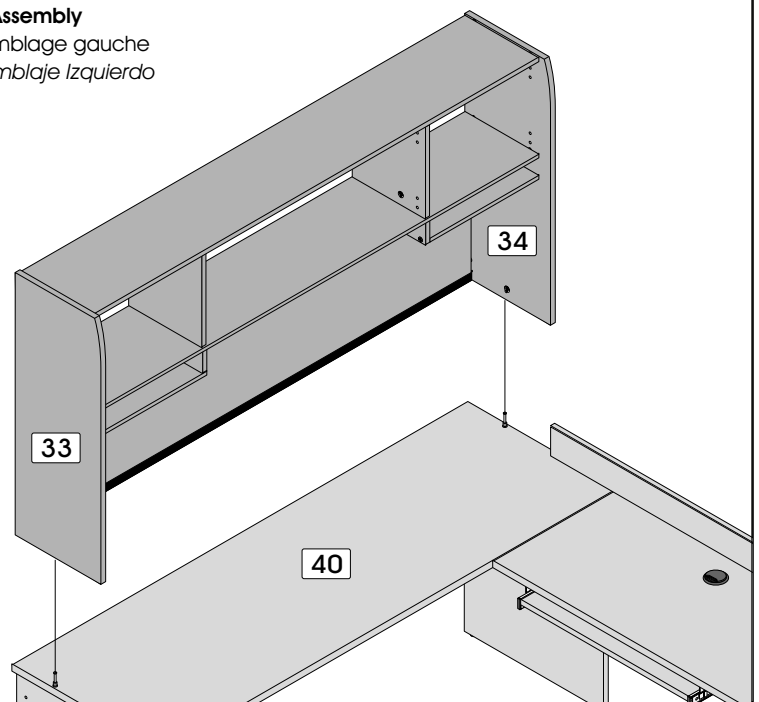



# 20 INSTALLATION / INSTALLATION / INSTALACIÓN

Back panel / Dos / Panel trasero



**two people are required to assemble and move this model.**  
 deux personnes sont requises pour assembler et déplacer ce modèle.  
 se necesitan dos personas para ensamblar y desplazar este mueble.

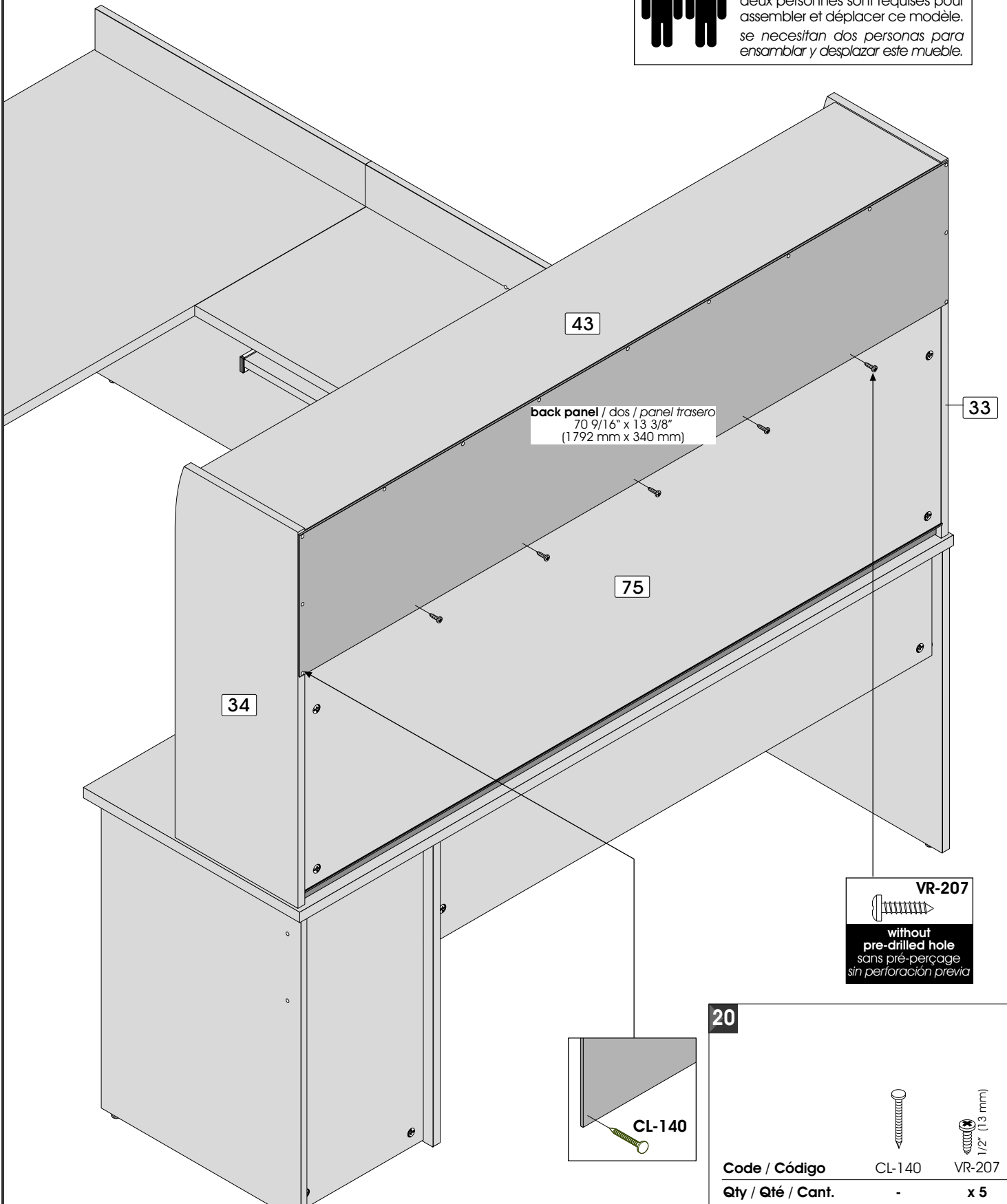

20		CL-140		VR-207
		-		x 5

SERVICE/SERVICIO: 1-888 8BESTAR (1-888 823-7827)

Desk / Bureau / Escritorio

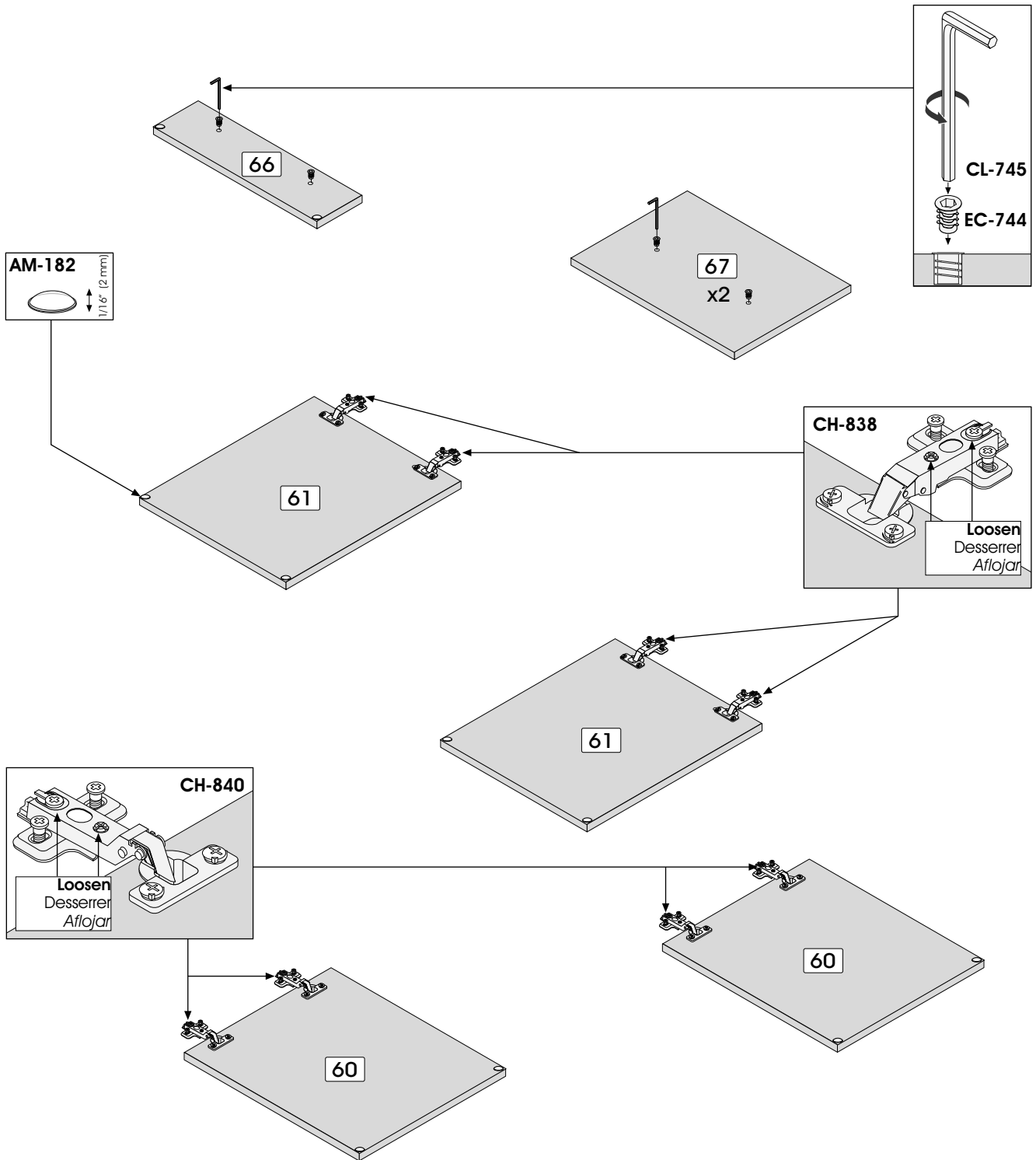

Code / Código	CH-838	CH-840	EC-744	CL-745	AM-182
Qty / Qté / Cant.	x 4	x 4	x 6	x 1	x 10

**Assembling sequence**  
 Séquence d'assemblage  
 Secuencia de ensamblaje  
**Parts / Pièces / Piezas:**

CA05A CA03A CA03A + bottom / fond / fondo + CA05A 66

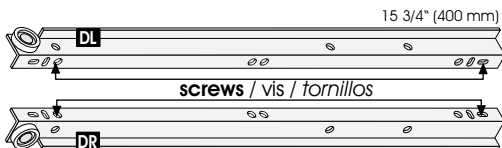
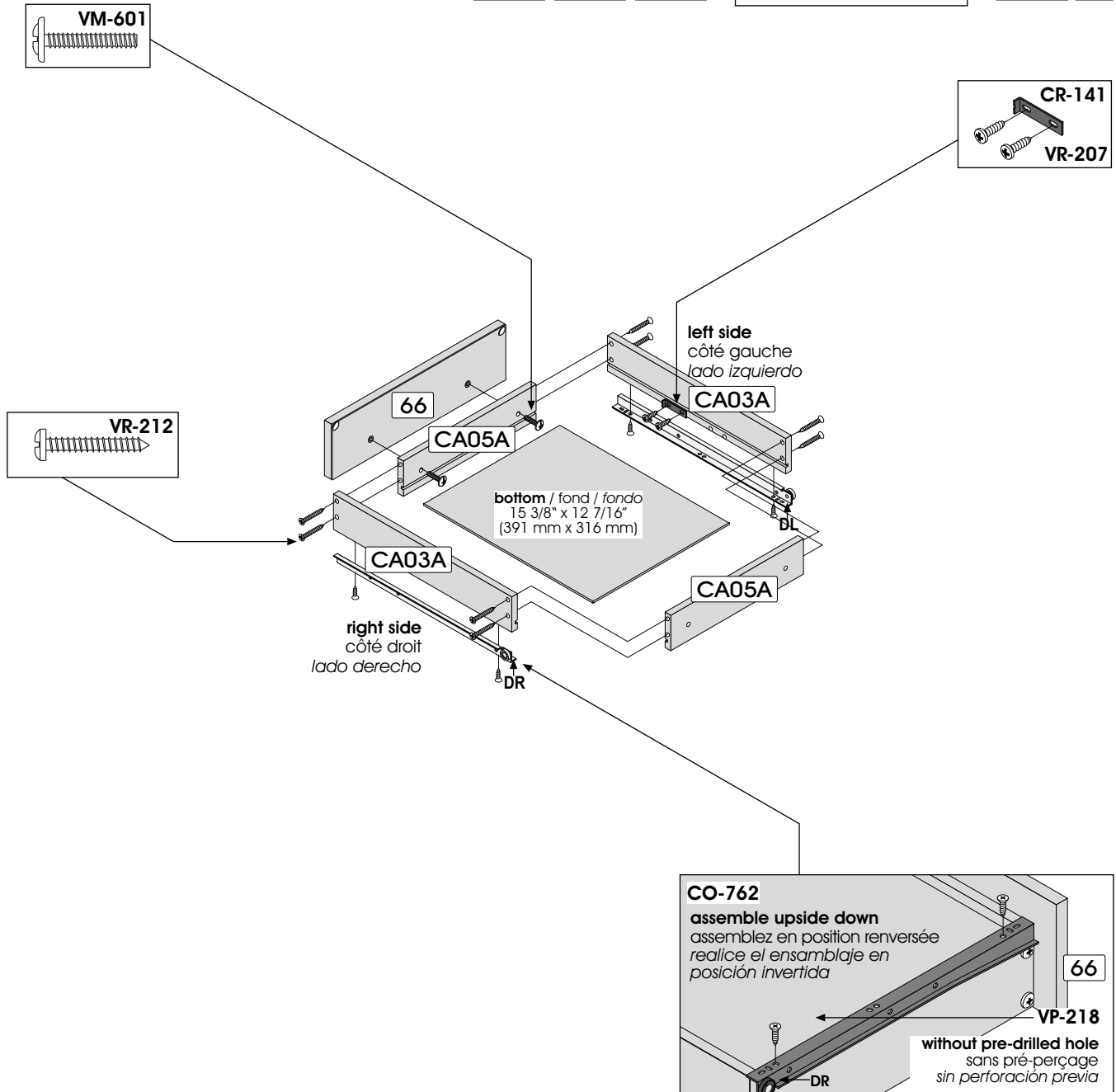

Code / Código  
 Qty / Qté / Cant.

CO-762  
 x 1



CR-141  
 x 1



VR-207  
 x 2



VP-218  
 x 4



VM-601  
 x 2



VR-212  
 x 8

## Drawers (2) / Tiroirs (2) / Cajónes (2)

### Assembling sequence

Séquence d'assemblage  
Secuencia de ensamblaje

### Parts / Pièces / Piezas:

CA13A EX-681 CA09A EX-702 CA09A EX-702 +  
bottom / fond / fondo + CA13A EX-681 67

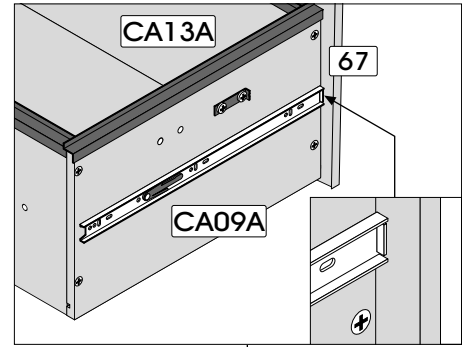
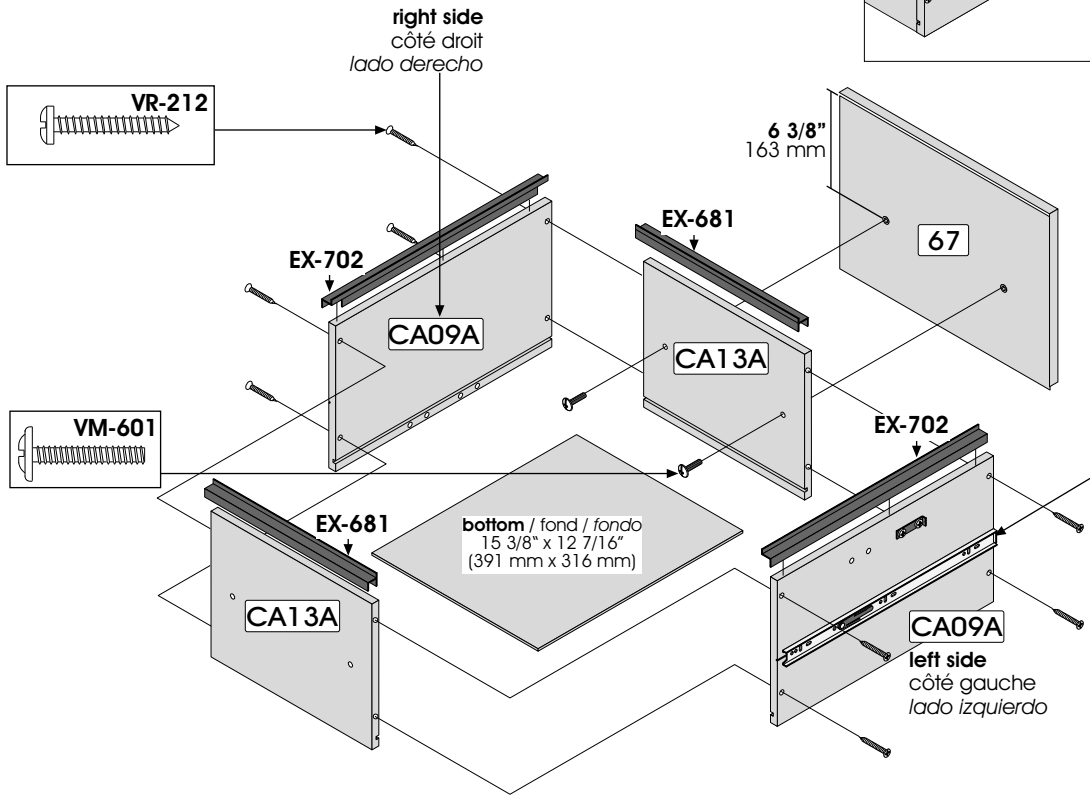

23

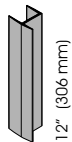

Code / Código EX-681

Qty / Qté / Cant. x 4

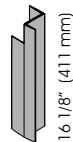

Code / Código EX-702

Qty / Qté / Cant. x 4



Code / Código VM-601

Qty / Qté / Cant. x 4



Code / Código VR-212

Qty / Qté / Cant. x 16

### filing / rangement / orden

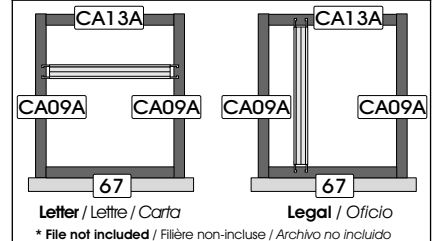

Letter / Lettre / Carta

Legal / Oficio

\* File not included / Filtre non-incluse / Archivo no incluido

Use screw A for horizontal adjustment, screw B for depth adjustment and screws C for vertical adjustment.

Utilisez la vis A pour l'ajustement horizontal, les vis B pour l'ajustement en profondeur et les vis C pour l'ajustement vertical.

Utilice el tornillo A para realizar el ajuste horizontal, los tornillos B para el ajuste de profundidad y los tornillos C para el ajuste vertical.

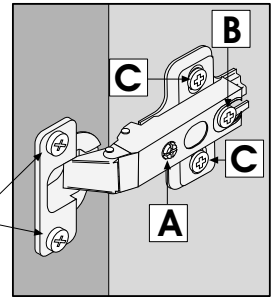

To remove hinges, start by loosening these two screws to free the locking system.

Pour enlever les pentures, desserrez ces deux vis d'abord pour libérer le système de verrouillage.

Para retirar las bisagras, afloje primero estos dos tornillos para liberar el sistema de fijación.

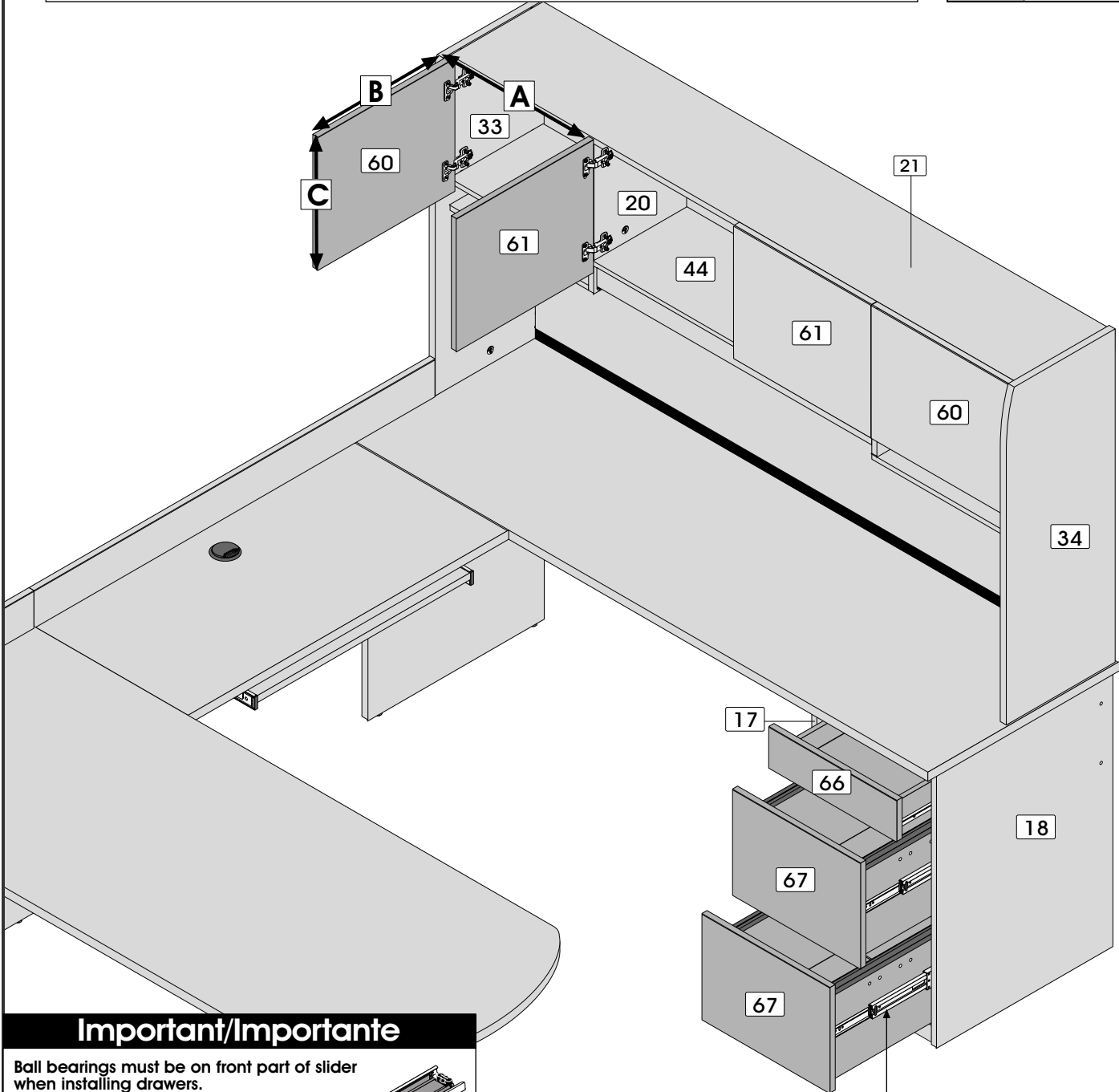

## Important/Importante

Ball bearings must be on front part of slider when installing drawers.

Les roulements à billes doivent être sur la partie avant du coulisseau lors de l'installation des tiroirs.

Los cojinetes de bolas deben ubicarse sobre la parte delantera de guía en el momento de instalar los cajones.

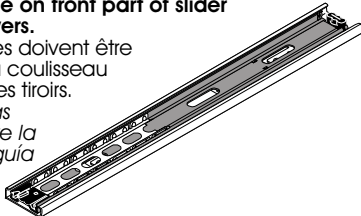

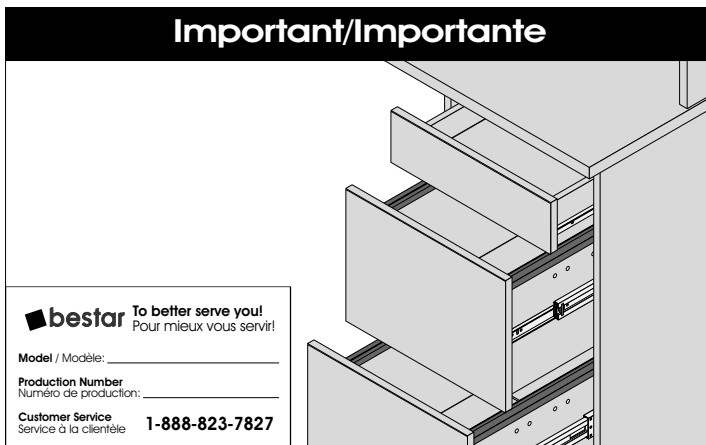
**Important/Importante**

For future reference and to better serve you, please apply the self-adhesive sticker in an accessible space such as inside a drawer.

Pour mieux vous servir en cas de besoin, veuillez apposer l'autocollant dans un endroit facilement accessible tel que l'intérieur d'un tiroir.

Para uno mejor servicio en caso de necesidad, poner la etiqueta en uno lugar de fácil acceso como por ejemplo al interior de un cajón.

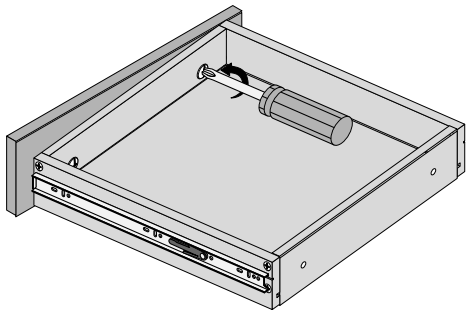

After installing drawers into cabinet, adjust drawer fronts and tighten screws VM-601.

Après avoir installé les tiroirs dans le meuble, ajustez les devants de tiroirs et resserrez les vis VM-601.

Después de instalar los cajones en el mueble, ajuste las partes delanteras de los cajones y vuelva atornillar a fondo los tornillos VM-601.

When you have completed the assembly of your new furniture, install plastic caps

Lorsque vous avez complété l'assemblage de votre meuble, installez les capuchons de plastique

Una vez que haya completado el ensamblaje del mueble, coloque los capuchones de plástico

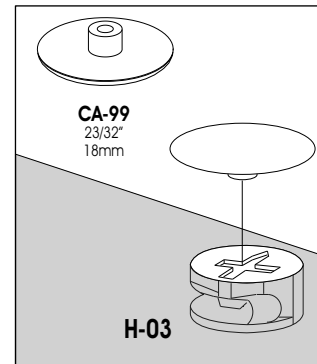
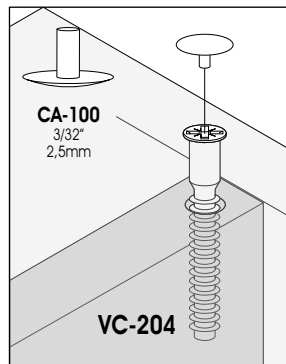
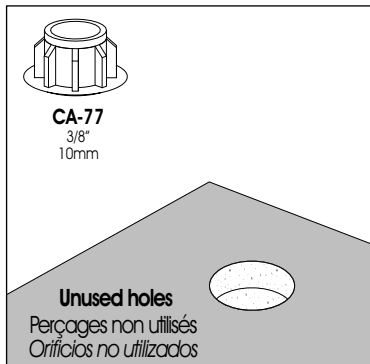
**PRODUCT CARE / ENTRETIEN DU PRODUIT / MANTENIMIENTO DEL PRODUCTO**

Avoid placing the furniture in the sunlight or near a source of heat. Use a soft dry cloth for dusting. To clean heavy dirt, use a cloth dipped in a solution of mild detergent and water. Avoid leaving wet objects on the surface or using commercial chemical cleaning products.

Évitez d'exposer le meuble au soleil ou près de toute source de chaleur. Pour le nettoyage, utilisez un chiffon doux et sec. Pour la grosse saleté, utilisez un chiffon humidifié avec un peu de détergent dilué dans l'eau. Évitez de laisser des objets mouillés sur la surface de votre meuble ou d'utiliser des nettoyeurs chimiques.

Evite exponer el mueble al sol o las fuentes de calor. Para limpiarlo, utilice un paño suave y seco. Para limpiar las manchas rebeldes, utilice un trapo húmedo con un poco de detergente diluido en agua. No deje objetos mojados encima del mueble ni utilice limpiadores que contengan productos químicos.

**CONGRATULATIONS! YOU ARE NOW THE OWNER OF A QUALITY PRODUCT**  
FÉLICITATIONS! VOUS AVEZ MAINTENANT EN VOTRE POSSESSION UN PRODUIT DE QUALITÉ  
¡FELICIDADES! AHORA ES USTED DUEÑO DE UN PRODUCTO DE CALIDAD.

1. **Gender / Sexe / Sexo**  Male / Homme / Hombre  Female / Femme / Mujer

2. **Age / Âge / Edad :**  -18  18-25  26-35  35-50  50 & +

3. **Last Name / Nom / Apellido :** \_\_\_\_\_

4. **First Name / Prénom / Nombre :** \_\_\_\_\_

5. **Address / Adresse / Dirección :** \_\_\_\_\_

6. **Apt. # :** \_\_\_\_\_ **City / Ville / Ciudad :** \_\_\_\_\_

7. **State / Province / Provincia :** \_\_\_\_\_ **Country / Pays / País :** \_\_\_\_\_

8. **Zip Code :** \_\_\_\_\_ **P.C. / C.P. :** \_\_\_\_\_

### About our Product / À propos du produit / Acerca del producto

9. **Model # / # modèle / Modelo N° :** \_\_\_\_\_

10. **Date of Purchase / Date d'achat / Fecha de compra :** \_\_\_\_\_

11. **Store Name / Détaillant / Tienda :** \_\_\_\_\_

12. **Which factors influenced your purchase? / Quels facteurs ont influencé votre achat? / Qué factores influyeron en su compra?**

Quality / Qualité / Calidad

Style / Appearance / Apariencia

Value for the price / Rapport qualité/prix / Relación calidad-precio

Recommendation / Recommendation / Recomendación

Store Display / Présentoir / Exhibidor

Brand Name / Marque / Marca  Price / Prix / Precio

Advertising / Publicité / Publicidad  Dimensions / Dimensión

13. **Where will this furniture primarily be used? / À quel endroit sera utilisé le meuble? / En qué lugar será utilizado el mueble?**

Office / Bureau / Oficina

Home Office / Bureau à la maison / Oficina del hogar

Family Room / Salle familiale / Sala familiar

Living Room / Salon / Salón

Bedroom / Chambre / Cuarto

Children's Room / Chambre d'enfant / Cuarto de niños

Other / Autre / Otro : \_\_\_\_\_

14. **The dimension of the room is approximately: / La dimension de la pièce est d'environ : / La dimensión del cuarto es de aproximadamente:**

80 sqft./pi²  120 sqft./pi²

100 sqft./pi²  140 sqft./pi²

15. **What kind of computer do you own? / Quel type d'ordinateur possédez-vous? / Qué tipo de computadora tiene usted?**

Desktop / Ordinateur de bureau / Computadora de escritorio

Laptop / Portable / Portátil

16. **If you bought a desk, which accessories would you need to complete your work space? / Si vous avez acheté un bureau, de quels accessoires auriez-vous besoin pour compléter votre espace de travail? / Si usted compró un escritorio, qué accesorios necesitaría para completar su espacio de trabajo?**

Lateral File. Letter/Legal Filing System / Fichier latérale. Classement de format lettre / legal / Archivo lateral. Clasificación para formato letra y legal

Bookcase / Bibliothèque / Biblioteca

Hutch / Étagère / Estantería

Other / Autre / Otro : \_\_\_\_\_

17. **The size of the work surface is: / La dimension de la surface de travail est : / La dimensión de la superficie de trabajo es:**

**Exactly what I was looking for** / Exactement ce que je recherchais / Exactamente lo que yo buscaba

**Bigger than what I was looking for** / Supérieure à ce dont je recherchais / Superior a la que yo buscaba

**Smaller than what I was looking for** / Inférieure à ce dont je recherchais / Inferior a la que yo buscaba

18. **The color of the furniture is: / La couleur du meuble est : / El color del mueble es:**

**Exactly what I was looking for** / Exactement ce que je recherchais / Exactamente el que yo buscaba

**Darker than what I was looking for** / Plus foncée que ce dont je recherchais / Superior al que yo buscaba

**Lighter than what I was looking for** / Plus pâle que ce dont je recherchais / Inferior al que yo buscaba

19. **The storage area is: / L'espace de rangement est : / El espacio de almacenamiento es:**

**Perfect / Idéal / Ideal**

**Too big / Trop grand / Demasiado grande**

**Too small / Trop petit / Demasiado pequeño**

### About Yourself / À propos de vous / Acerca de usted

20. **Marital status / Statut / Estado Civil**

Married / Marié / Casado (a)

Single / Célibataire / Soltero (a)

Divorced / Divorcé / Divorciado

21. **Including yourself, how many people live in your household? / Incluant vous-même, combien de personnes habitent sous votre toit? / Incluyéndose usted, cuántas personas viven bajo su techo?**

1  2  3  4  5  6 & +

22. **Occupation / Occupation**

Professional / Professionnel / Profesional

Upper Management / Haute direction / Gerente

Middle Management / Direction / Director

Marketing / Commercialisation / Comerciante

Clerical / Employé de bureau / Empleado de oficina

A Student / Étudiant / Estudiante

Business Owner / Entrepreneur / Empresario

Number of employees / Nombre d'employés / Número de empleados

1-5  6-9  10-19  20 & +

23. **Which group describes your annual family income? / Quel groupe décrit votre revenu annuel familial? / Qué grupo describe su renta anual familiar?**

- \$15,000  \$50,000 - \$74,999

\$15,000 - \$19,999  \$75,000 - \$99,999

\$20,000 - \$29,999  \$100,000 - \$149,000

\$30,000 - \$39,999  \$150,000 & +

\$40,000 - \$49,999

### Thanks / Merci / Gracias

Thanks for taking the time to fill out this questionnaire. Your answers will help us serve you in the future. We value your suggestions and comments and look forward to hearing from you. Merci d'avoir pris le temps de compléter ce questionnaire. Vos réponses nous aideront à mieux vous servir dans le futur. Vos suggestions et commentaires ont une grande importance pour nous. Gracias por tomar el tiempo de completar este cuestionario. Sus respuestas nos ayudarán a servirle mejor en el futuro. Sus sugerencias y comentarios tienen una gran importancia para nosotros.



First Class  
Postage  
Here  
Affranchir  
suffisamment

Product Registration Card / Carte d'enregistrement du produit  
Tarjeta de registro del producto

Dear Customer,

Thank you for choosing Bestar furniture. At Bestar our goal is to produce high-quality, durable, fashionable furniture at affordable prices in order to satisfy our customers' needs. That's why we are asking a valued customer like you to take a few moments to help us with the following questionnaire. We would greatly appreciate your input.

Cher client(e),

Merci d'avoir acheté un meuble Bestar. Chez Bestar, notre but est de produire des meubles de qualité, durables, esthétiques et à prix abordable pour satisfaire les besoins de nos clients. C'est pourquoi nous demandons à un client d'importance tel que vous de prendre quelques minutes pour compléter ce questionnaire. Nous apprécions votre implication.

Querido (a) cliente,

Gracias por comprar un Mueble Bestar. En Bestar, nuestro objetivo es producir muebles de calidad, duraderos, estéticos y a un precio razonable para satisfacer las necesidades de nuestros clientes. Es por esta razón que le pedimos a un cliente tan importante como usted de tomar algunos minutos para completar este cuestionario. Apreciaremos su participación.

Addicted to Innovation / La passion de l'innovation / La pasión de la innovación



Seal with tape / Cacheter avec du ruban adhésif / Sellar con cinta adhesiva

Product Registration Card / Carte d'enregistrement du produit  
Tarjeta de registro del producto

Please complete and return this questionnaire to us either by regular mail or via our internet site.

Vous pouvez compléter et nous retourner ce questionnaire par la poste ou via notre site internet.

Usted puede completar y enviarnos este cuestionario por correo o a través nuestro sitio internet.

[www.bestar.ca](http://www.bestar.ca)

Addicted to Innovation / La passion de l'innovation / La pasión de la innovación

