



**BESTAR**

MODEL: MODÈLE: *MODELO*  
**81411-2175-2275**

SECRET MAPLE & CHOCOLATE : ÉRABLE SECRET ET CHOCOLAT : *ARCE SECRETO Y CHOCOLATE*  
WWW.BESTAR.CA : 1-888-8BESTAR (1 888 823-7827)

**81411-2139-2239**

BORDEAUX & GRAPHITE : BORDEAUX ET GRAPHITE : *BURDEOS Y GRAFITO*  
WWW.BESTAR.CA : 1-888-8BESTAR (1 888 823-7827)

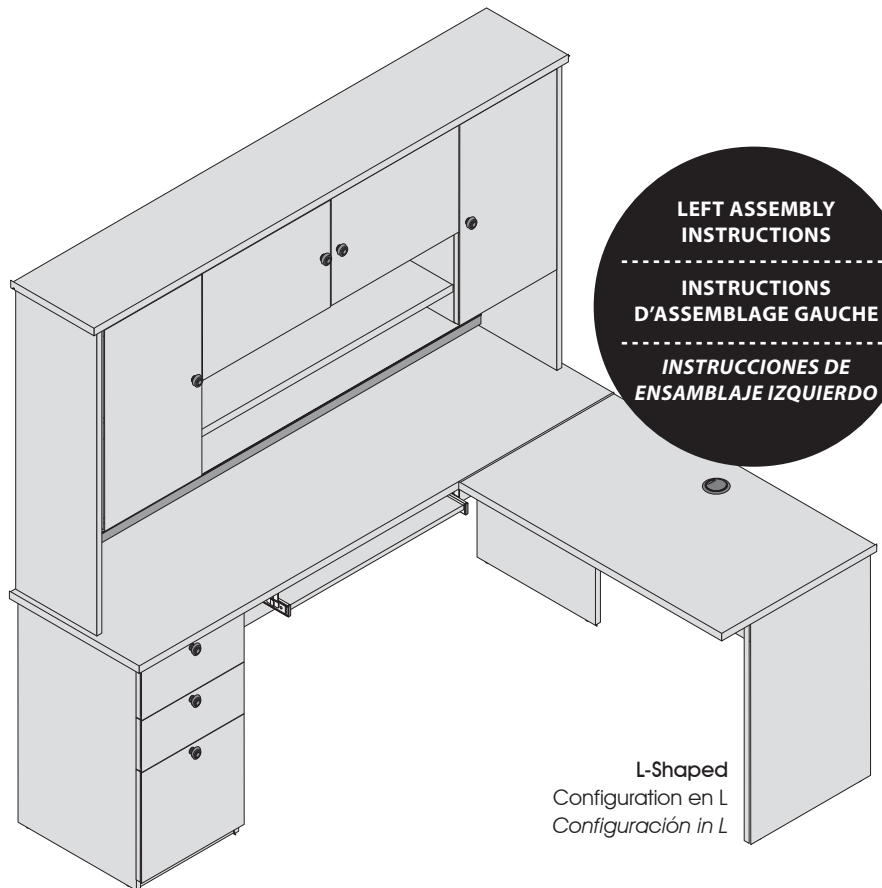







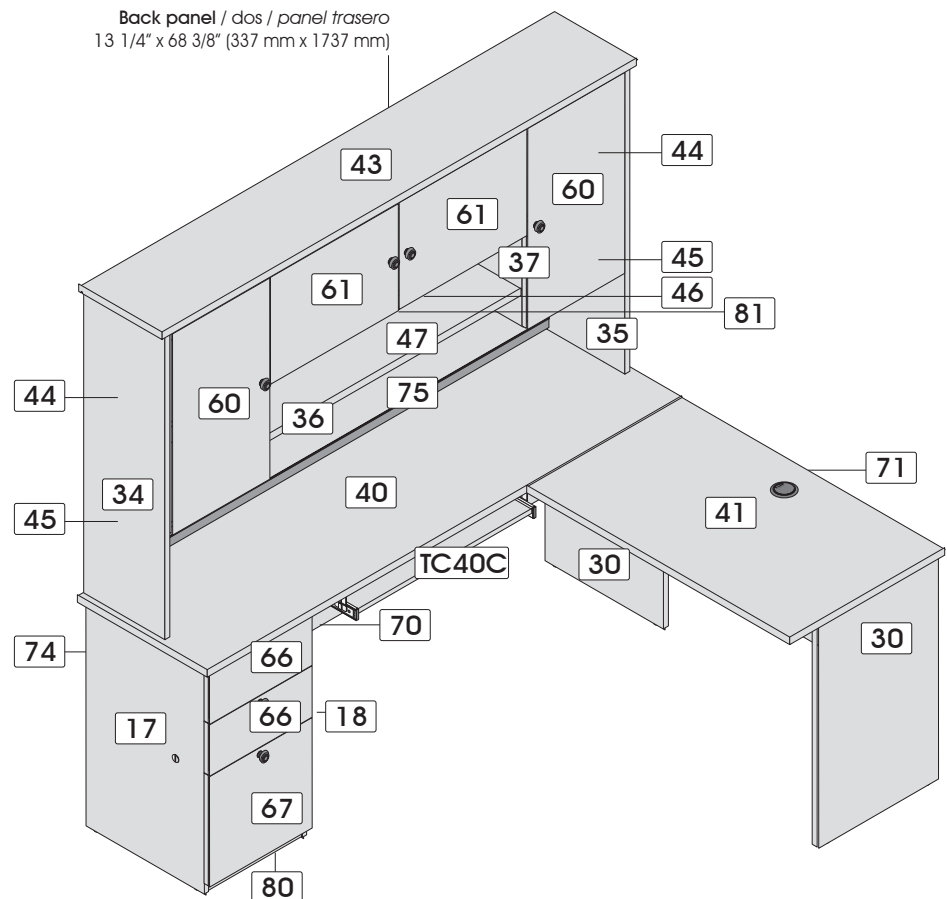











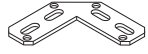
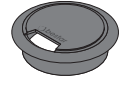

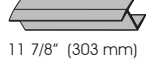

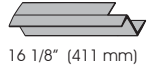
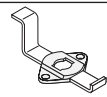

► PARTS / PIÈCES / PIEZAS



| CODE / CÓDIGO | QTY / QTÉ / CANT. | CODE / CÓDIGO | QTY / QTÉ / CANT. | CODE / CÓDIGO | QTY / QTÉ / CANT. | CODE / CÓDIGO  | QTY / QTÉ / CANT. |
|---------------|-------------------|---------------|-------------------|---------------|-------------------|--|-------------------|
| CA01A         | 4                 | 34            | 1                 | 45            | 2                 | 71   | 1                 |
| CA05A         | 4                 | 35            | 1                 | 46            | 1                 | 74   | 1                 |
| CA09A         | 2                 | 36            | 1                 | 47            | 1                 | 75   | 1                 |
| CA13A         | 2                 | 37            | 1                 | 60            | 2                 | 80   | 1                 |
| TC40C         | 1                 | 40            | 1                 | 61            | 2                 | 81   | 1                 |
| 17            | 1                 | 41            | 1                 | 66            | 2                 | Back panel / dos / panel trasero<br>13 1/4" x 68 3/8" (337 mm x 1737 mm) | 1                 |
| 18            | 1                 | 43            | 1                 | 67            | 1                 | Bottom / fond / fondo<br>12 7/16" x 15 3/8" (316 mm x 391 mm)            | 3                 |
| 30            | 2                 | 44            | 2                 | 70            | 1                 |  |                   |

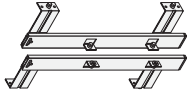
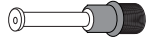

**HARDWARES / QUINCAILLERIES / QUINCALLAS**

| CODE / CÓDIGO   | QTY / QTÉ / CANT. | CODE / CÓDIGO   | QTY / QTÉ / CANT. | CODE / CÓDIGO  | QTY / QTÉ / CANT. | CODE / CÓDIGO   | QTY / QTÉ / CANT. |
|---|-------------------|---|-------------------|--|-------------------|---|-------------------|
| AM-182  1/16" (2 mm) | 4                 | CR-141                   | 2                 | PA-844  1" (25 mm)    | 8                 | VF-232  7/8" (22 mm) | 7                 |
| CA-77                | 6                 | EC-744                   | 6                 | PF-106                | 1                 | VM-601  3/4" (20 mm) | 6                 |
| CA-99                | 35                | EQ-143                   | 2                 | PF-108               | 1                 | VR-207  1/2" (13 mm) | 24                |
| CH-840               | 8                 | EX-681  11 7/8" (303 mm) | 2                 | PO-777                | 7                 | VR-212  1" (25 mm)   | 34                |
| CL-140               | -                 | EX-702  16 1/8" (411 mm) | 2                 | SE-686                | 1                 |   |                   |
| CL-745               | 1                 | EX-766                   | 1                 | TI-365                | 4                 |   |                   |
| CO-249 <b>runners 406 mm (16")</b><br>coulisseaux 406 mm<br>correderas 406 mm                         | 3                 | H-03                     | 58                | TI-552                | 5                 |   |                   |
| CO-843               | 1                 | H-36                     | 56                | VE-244  3/8" (10 mm) | 18                |   |                   |

**REAL SIZE / GRANDEUR RÉELLE / TAMAÑO REAL**

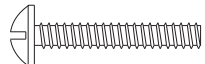
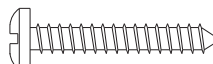
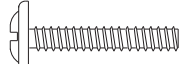
| CODE / CÓDIGO   | QTY / QTÉ / CANT. | CODE / CÓDIGO  | QTY / QTÉ / CANT. |
|---|-------------------|--|-------------------|
| VE-244  3/8" (10 mm) | 18                | VR-207  1/2" (13 mm) | 24                |
| VF-232  7/8" (22 mm) | 7                 | VR-212  1" (25 mm)   | 34                |
| VM-601  3/4" (20 mm) | 6                 |  |                   |

**► PROBLEMS OR INFORMATION**  
POUR TOUT PROBLÈME OU INFORMATION  
PROBLEMAS O INFORMACIÓN

**www.bestar.ca**  
1888 823-7827

# ▶ IMPORTANT NOTICE / NOTE IMPORTANTE / NOTA IMPORTANTE

Duly complete the self-adhesive sticker. / Assurez-vous de bien remplir l'auto-collant. / Asegúrese de completar correctamente la etiqueta.

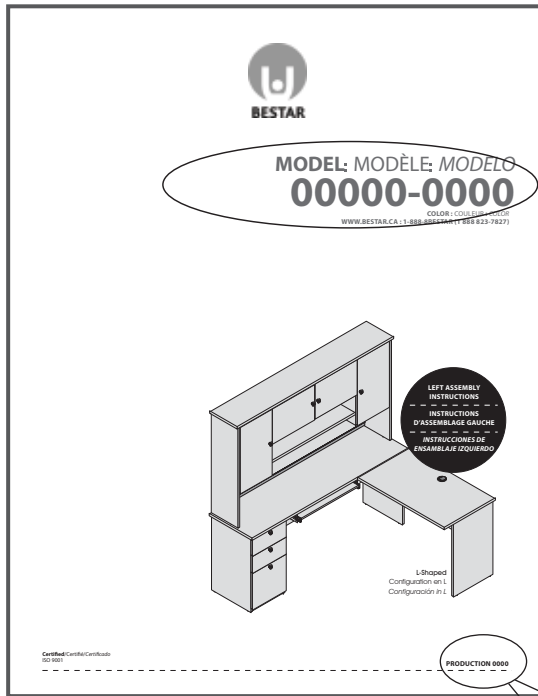

**PRODUCTION 0000**

**BESTAR**

To better serve you!  
Pour mieux vous servir!

Model / Modèle: \_\_\_\_\_

Production Number  
Numéro de production: \_\_\_\_\_

Customer Service  
Service à la clientèle **1-888-823-7827**

**Important/Importante**

Please retain the self-adhesive sticker which you will install at page 25 of the instruction manual.

Conservez l'autocollant qui sera collé seulement à la page 25 du feuillet d'instructions.

Conserve la etiqueta que será pegada sólo en la página 25 de la hoja de instrucciones.

## IMPORTANT NOTICE / NOTE IMPORTANTE / NOTA IMPORTANTE

H-03

arrow  
flèche  
flecha

Insert the cam with the arrow pointing towards the hole in the edge.

Insérez la rondelle en pointant la flèche vers le trou de la bordure.

Inserte la arandela con la flecha apuntando hacia el orificio cercano al borde.

### Main hardware system / Système de quincaillerie principal / Sistema principal de quincalla

1 insert / insérez / insertar

2 tools required / outils requis / herramientas necesarias

3 tighten / serrez / apretar

**important / importante**

How to remove a misplaced assembly bolt (H-36).  
Comment retirer un boulon (H-36) mal situé.  
Cómo retirar un perno (H-36) mal ubicado.

A turn / tournez / haga girar

B pull out / retirez / retire

SERVICE/SERVICIO: 1-888 8BESTAR (1-888 823-7827)

**Credenza / Crédence / Credencia**

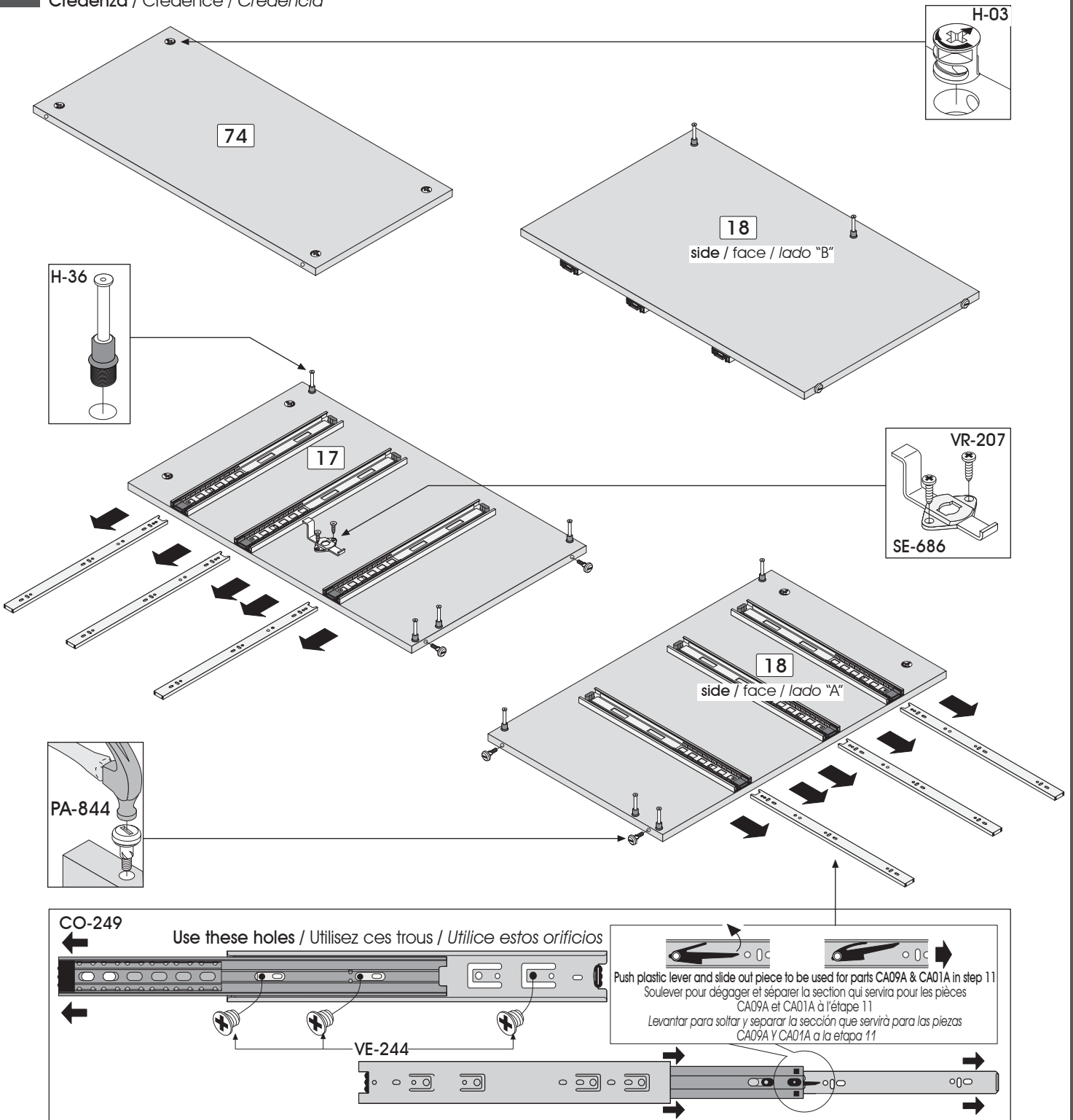



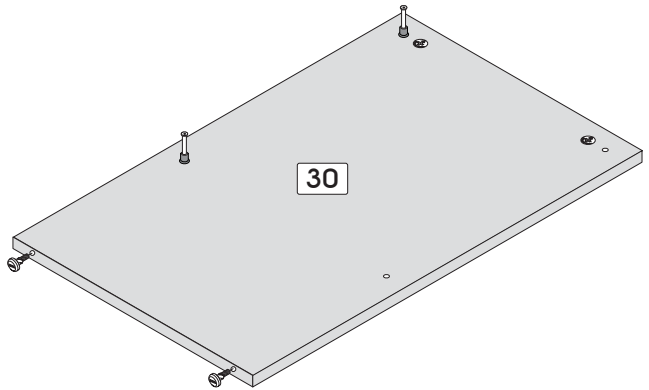
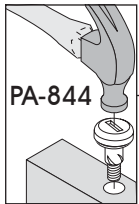
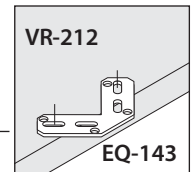
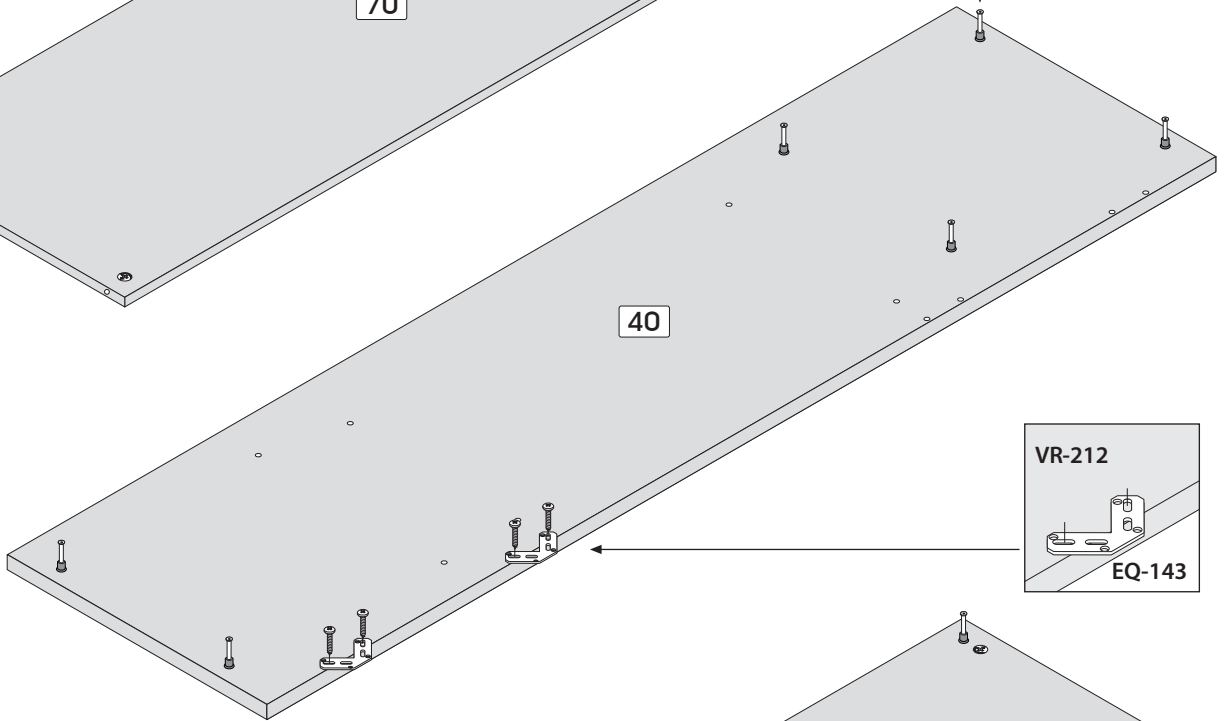
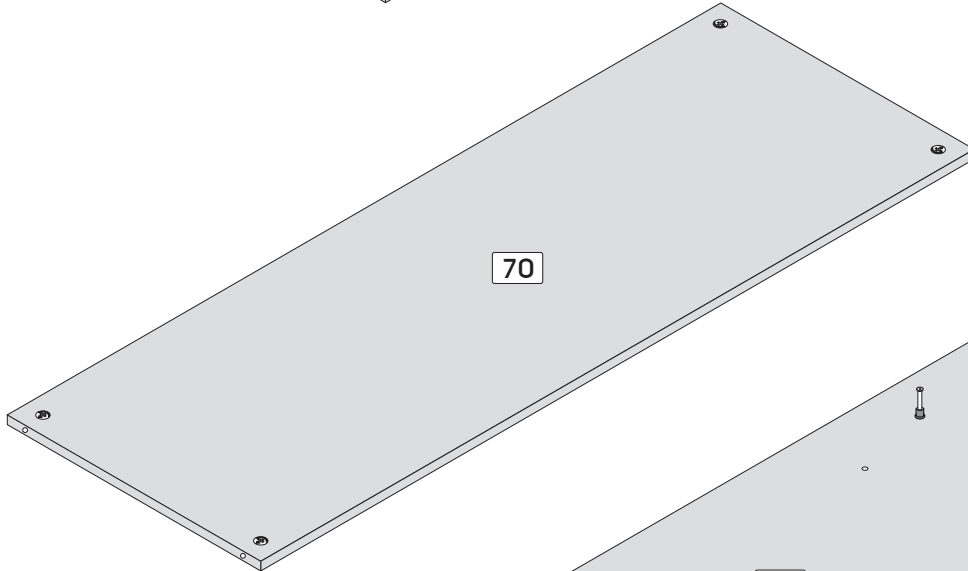
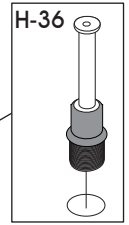
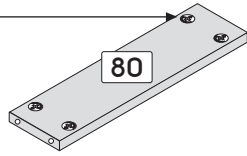
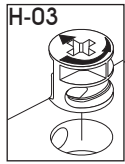

|                          |        |      |      |        |        |        |        |
|--------------------------|--------|------|------|--------|--------|--------|--------|
| <b>1</b>                 |        |      |      |        |        |        |        |
| <b>Code / Código</b>     | CO-249 | H-03 | H-36 | PA-844 | SE-686 | VR-207 | VE-244 |
| <b>Qty / Qté / Cant.</b> | x 3    | x 8  | x 10 | x 4    | x 1    | x 2    | x 18   |

# 2 HARDWARE INSTALLATION / INSTALLATION DES QUINCAILLERIES / INSTALACIÓN DE LAS QUINCALLAS

Credenza / Crédence / Credencia

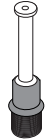

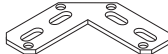
2

|                   |   |   |   |   |   |
|-------------------|---|---|---|---|---|
|                   |  |  |  |  |  |
| Code / Código     | H-03  | H-36  | PA-844  | EQ-143  | VR-212  |
| Qty / Qté / Cant. | x 10  | x 8   | x 2   | x 2   | x 4   |

SERVICE/SERVICIO: 1-888 8BESTAR (1-888 823-7827)

# IMPORTANT NOTICE / NOTE IMPORTANTE / NOTA IMPORTANTE

## ▶ Main hardware system / Système de quincaillerie principal / Sistema principal de quincalla

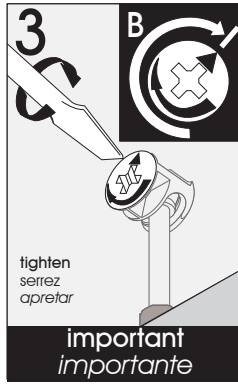
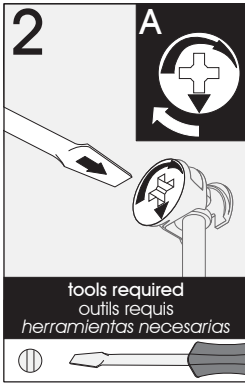
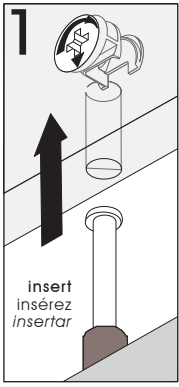

Make sure to properly tighten each cam to ensure furniture solidity. Otherwise, parts could be damaged or the user could be injured.

Assurez-vous de bien resserrer chaque rondelle pour assurer la solidité du meuble. Dans le cas contraire, des pièces pourraient être endommagées ou l'utilisateur pourrait se blesser.

Asegúrese de apretar bien cada arandela para garantizar la solidez del mueble. De lo contrario, podría provocarse daño a las piezas o las personas.

## 3 ASSEMBLY / ASSEMBLAGE / ENSAMBLAJE

### Credenza / Crédence / Credencia

#### Assemble upside down

Assemblez en position renversée

Realice el ensamblaje en posición invertida

#### Assembling sequence

Séquence d'assemblage

Secuencia de ensamblaje

Parts / Pièces / Piezas:

17 74 80 18 70 30 40



unfinished edge  
bordure non-finie  
borde sin acabado

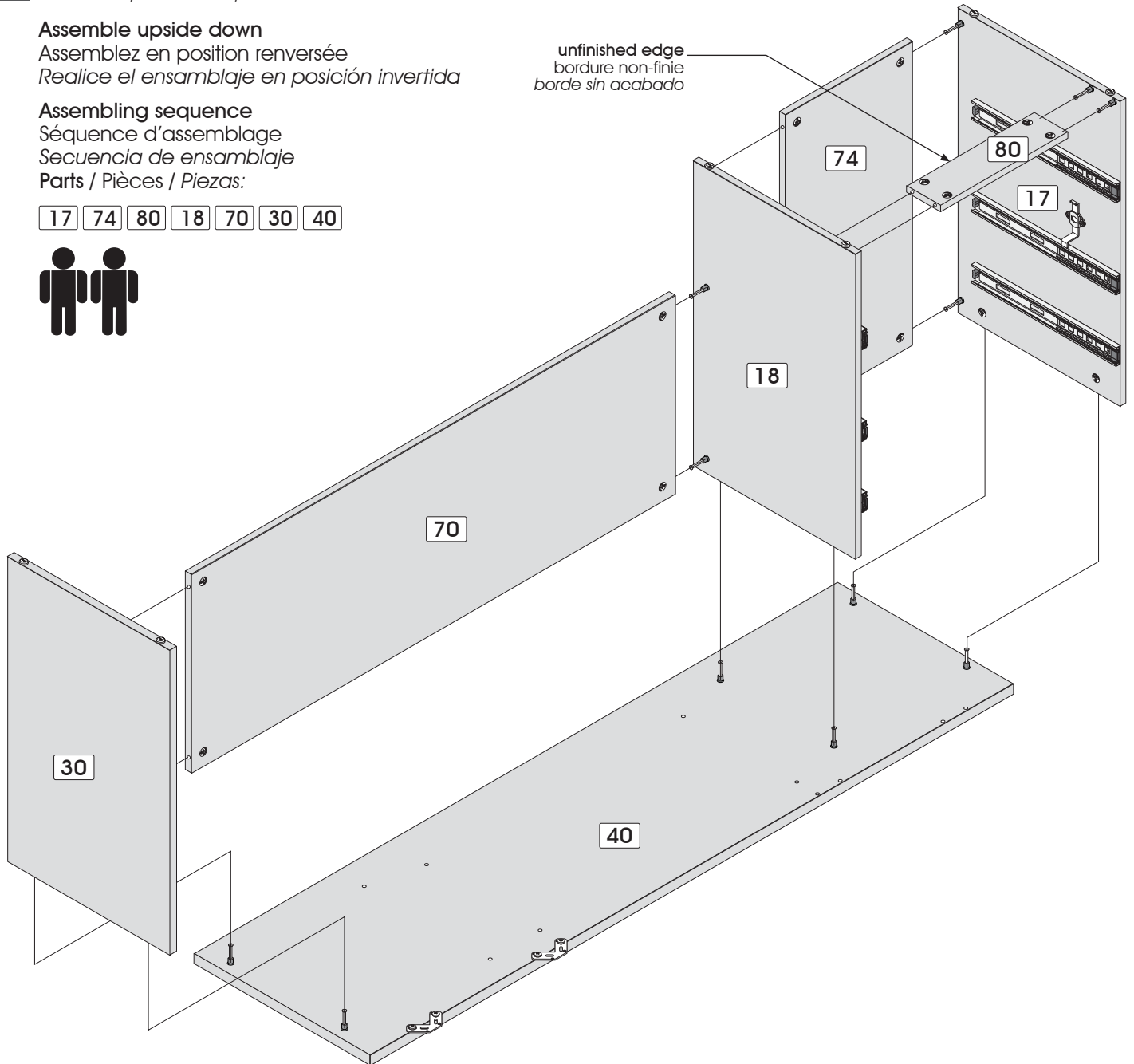



SERVICE/SERVICIO: 1-888 8BESTAR (1-888 823-7827)

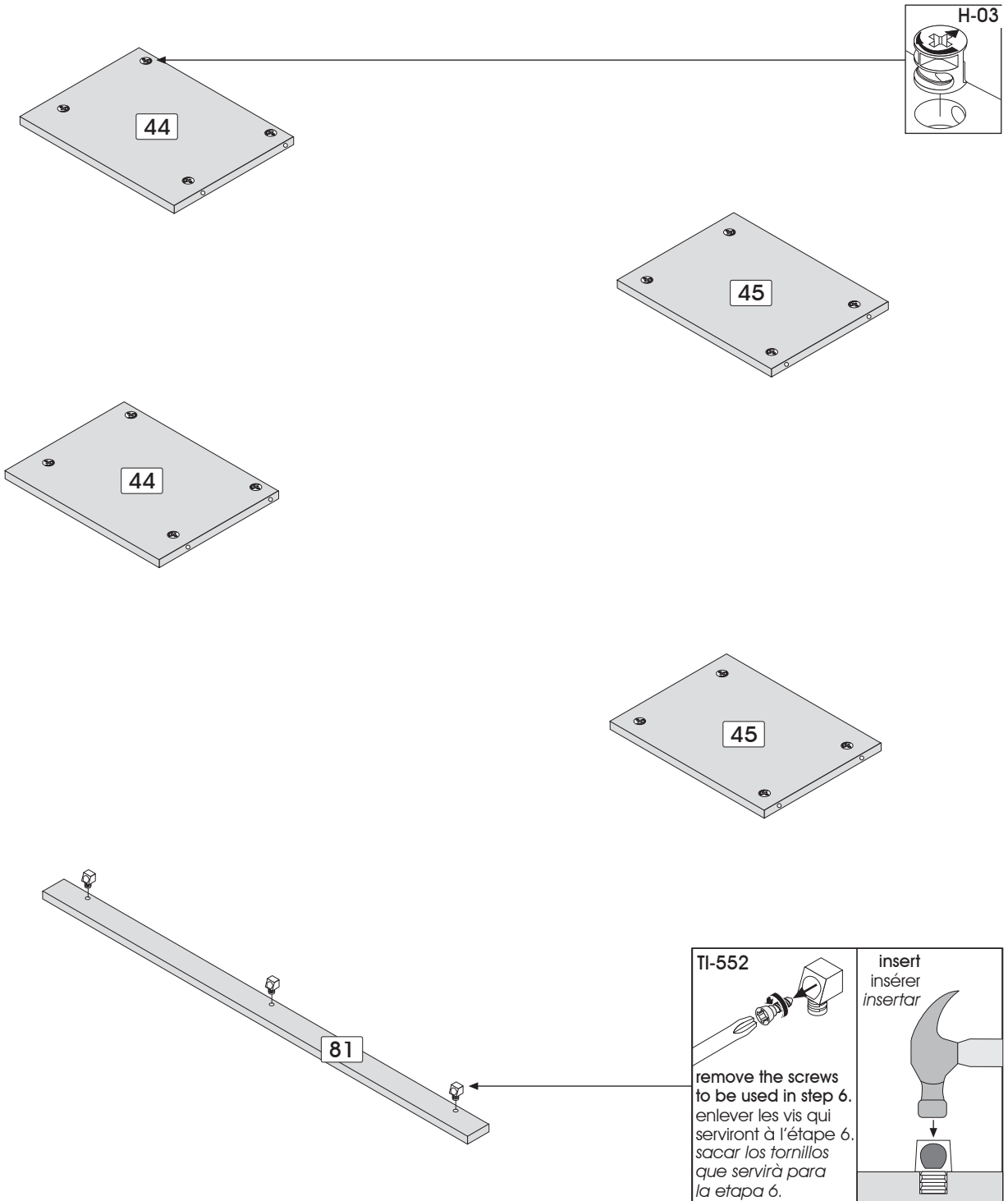

Hutch / Étagère / Estantería



4

|                   |  |  |
|-------------------|--|--|
| Code / Código     |  H-03 |  TI-552 |
| Qty / Qté / Cant. | x 16   | x 3  |

Hutch / Étagère / Estantería

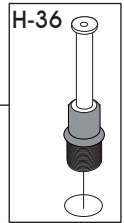
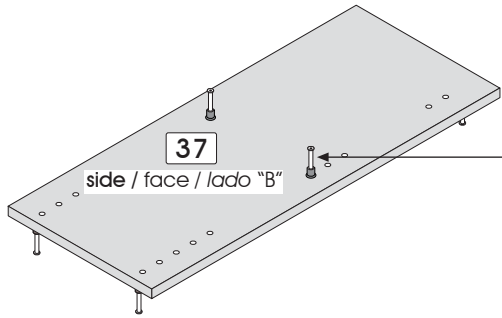
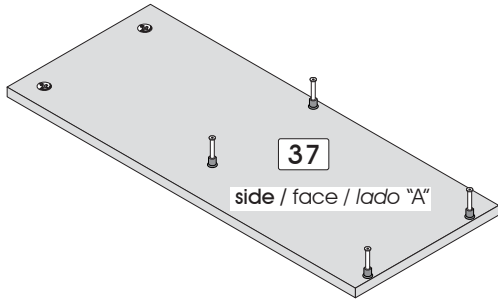
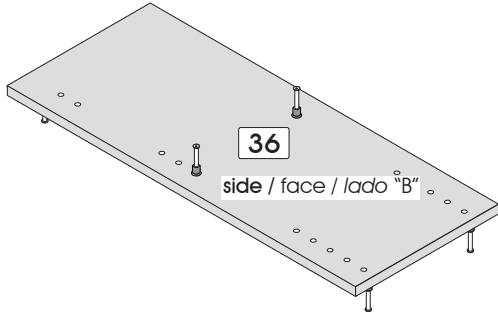
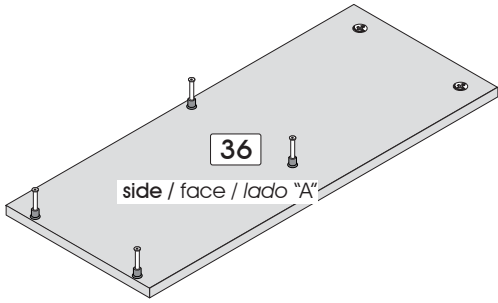
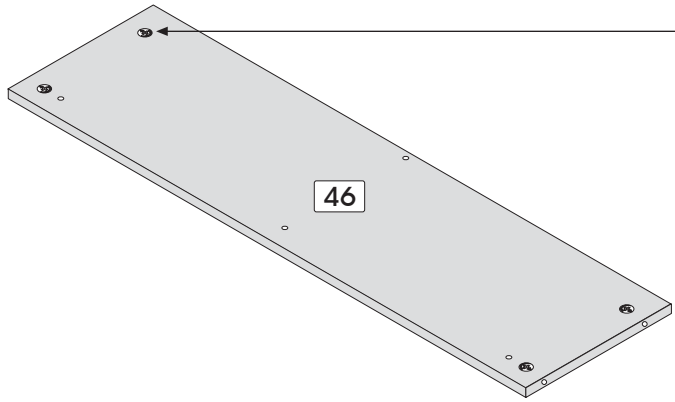
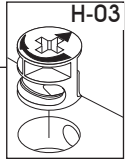

5



H-03

x 8

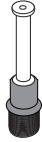

H-36

x 12

Code / Código  
Qty / Qté / Cant.

Assemble on the front edge  
 Assemblez sur la bordure avant  
 Realice el ensamblaje sobre el borde delantero

Assembling sequence  
 Séquence d'assemblage  
 Secuencia de ensamblaje

Parts / Pièces / Piezas:

46 37 36 44 44 45 45 81

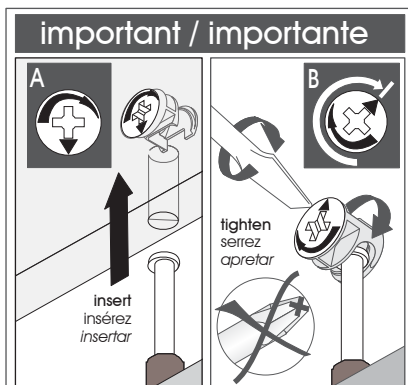
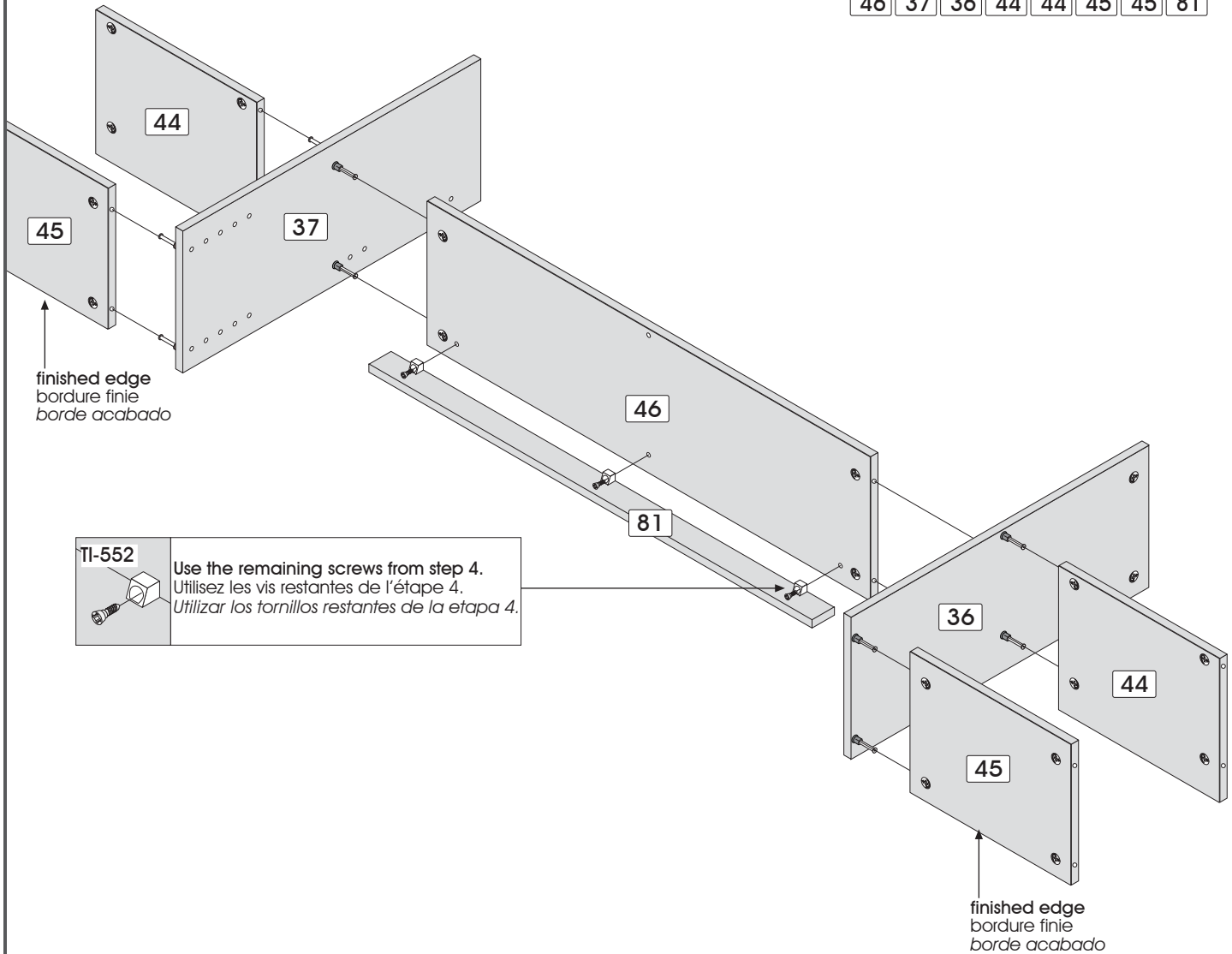

**7** HARDWARE INSTALLATION / INSTALLATION DES QUINCAILLERIES / INSTALACIÓN DE LAS QUINCALLAS

Hutch / Étagère / Estantería

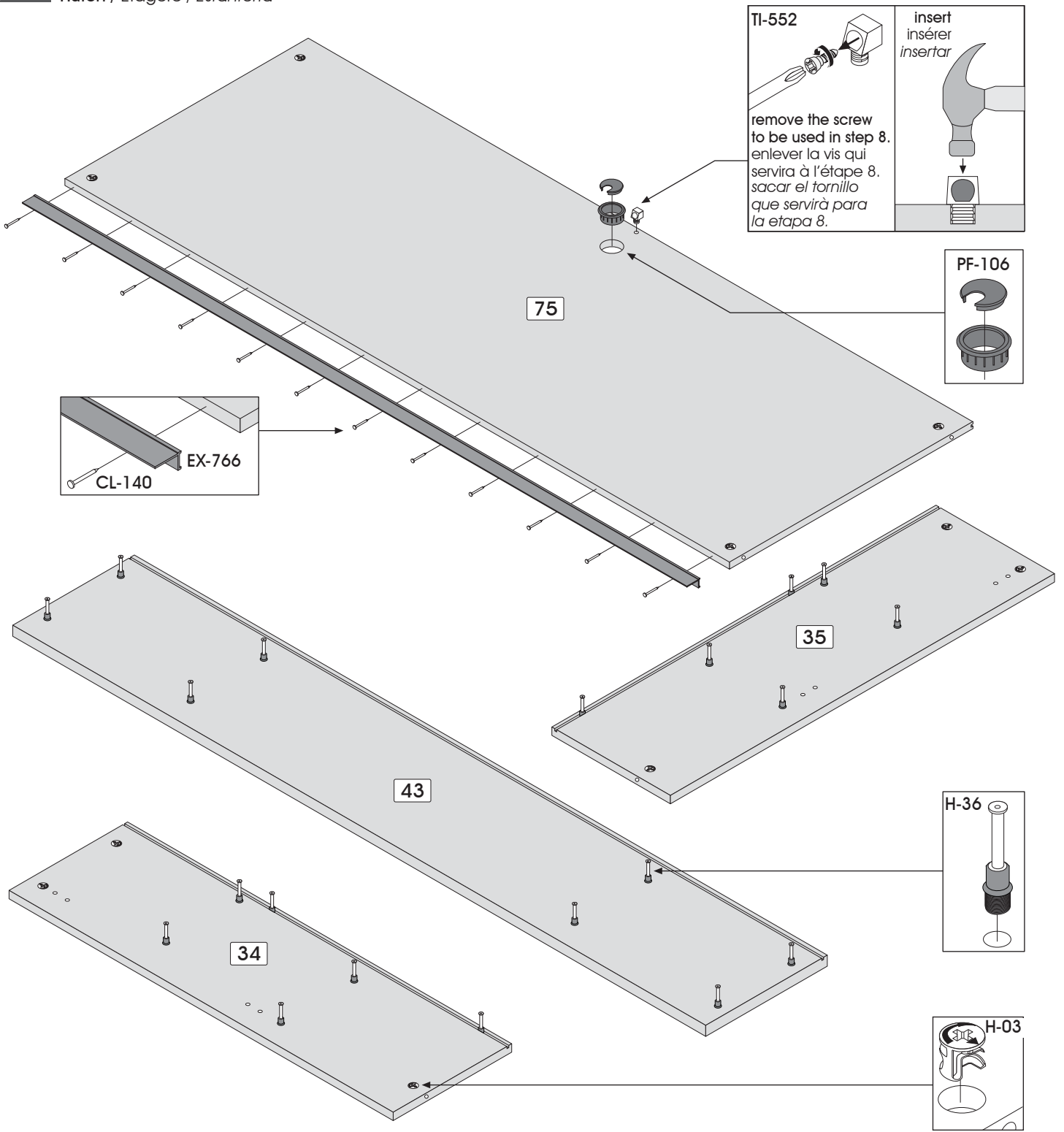

**TI-552**

remove the screw to be used in step 8.  
enlever la vis qui servira à l'étape 8.  
sacar el tornillo que servirá para la etapa 8.

insert  
insérer  
insertar

**PF-106**

**EX-766**

**CL-140**

**H-36**

**H-03**

| Code / Código     | H-03 | H-36 | TI-552 | PF-106 | EX-766 | CL-140 |
|-------------------|------|------|--------|--------|--------|--------|
| Qty / Qté / Cant. | x 10 | x 20 | x 1    | x 1    | x 1    | -      |

SERVICE/SERVICIO: 1-888 8BESTAR (1-888 823-7827)

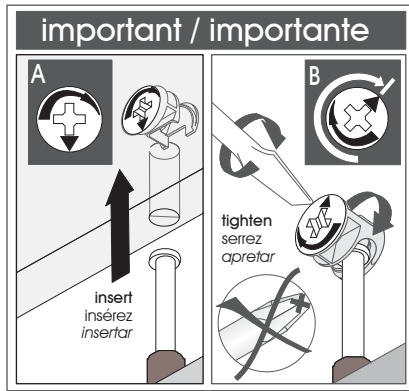

**Assemble on the back edge**  
 Assemblez sur la bordure arrière  
 Realice el ensamblaje sobre el borde trasero

**Assembling sequence**  
 Séquence d'assemblage  
 Secuencia de ensamblaje  
**Parts / Pièces / Piezas:**

75 34 + 44 45 36 37 45 44  
 + 35 + back panel / dos / panel trasero + 43

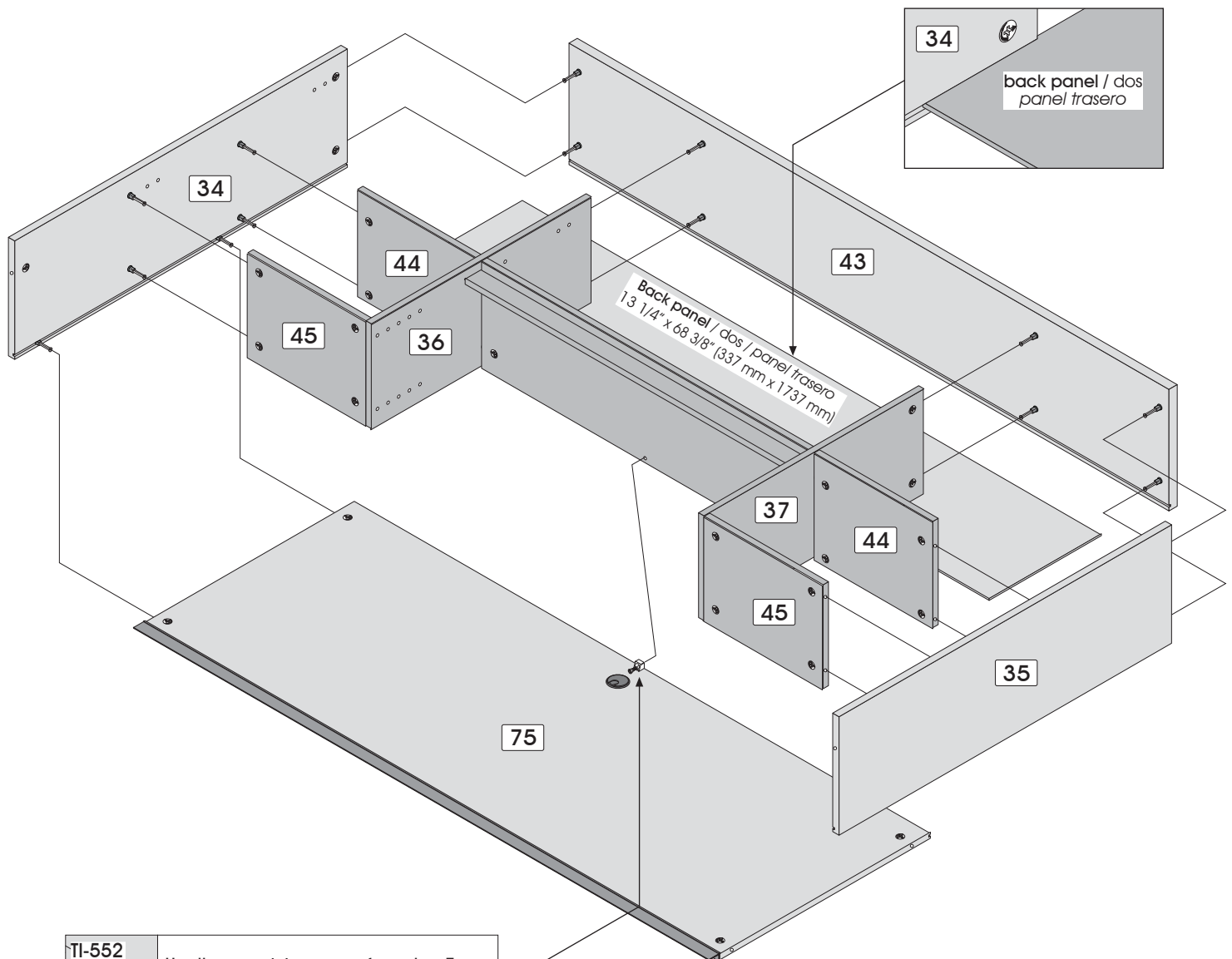

TI-552



Use the remaining screw from step 7.  
 Utilisez la vis restante de l'étape 7.  
 Utilizar el tornillo restante de la etapa 7.

Hutch / Étagère / Estantería

Assembling sequence  
 Séquence d'assemblage  
 Secuencia de ensamblaje  
 Parts / Pièces / Piezas:

40 + 34 35

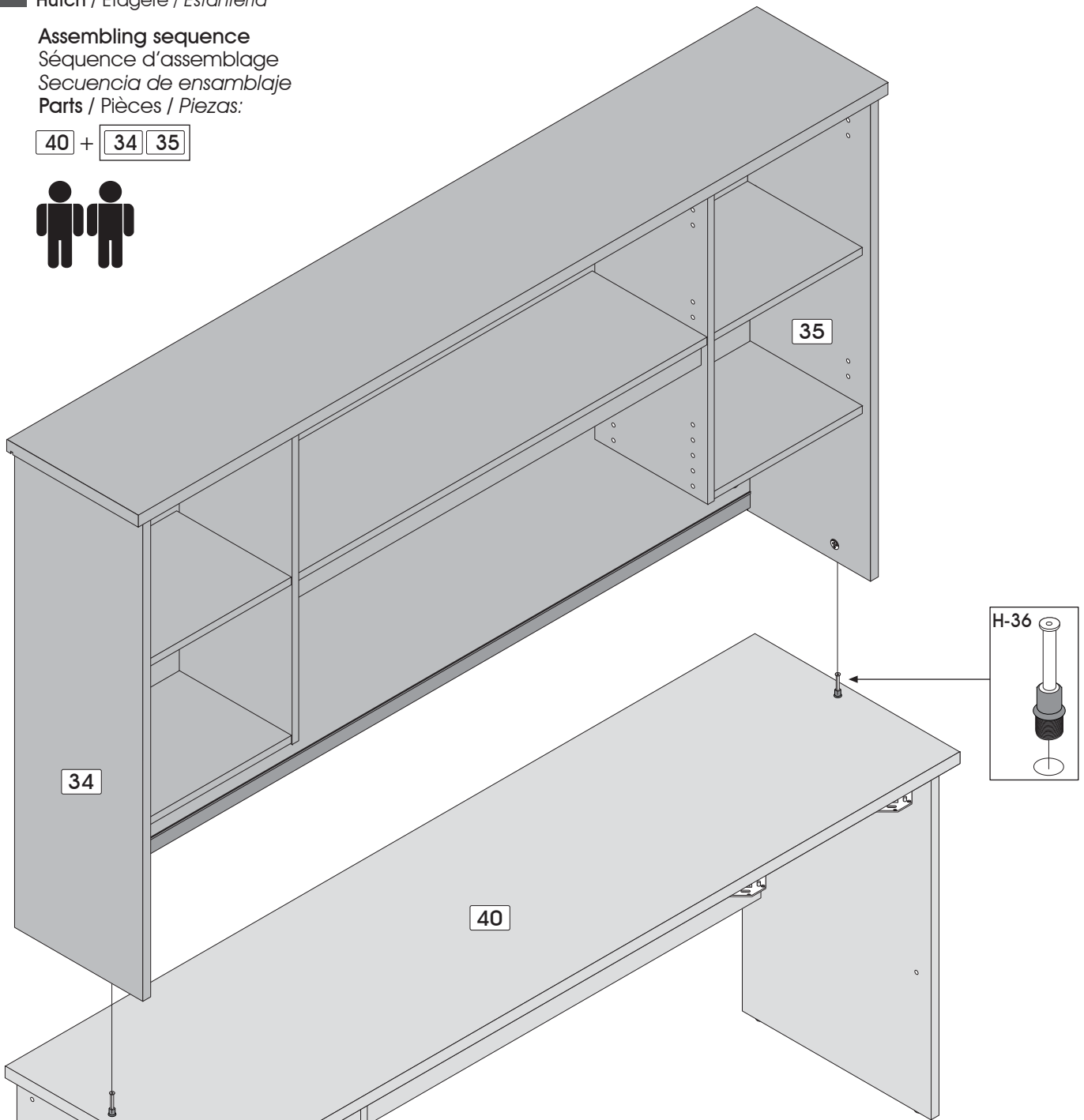

**important / importante**

**A**

↑  
insert  
insérez  
insertar

**B**

tighten  
serrez  
apretar

9

Code / Código      H-36  
 Qty / Qté / Cant.      x 2

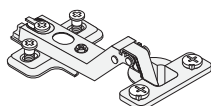
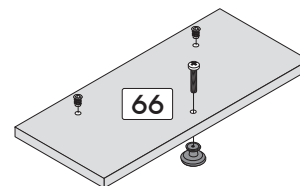
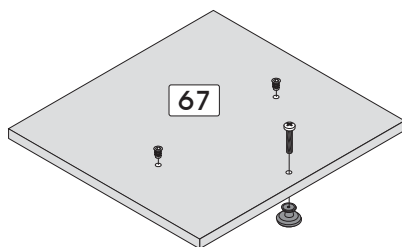
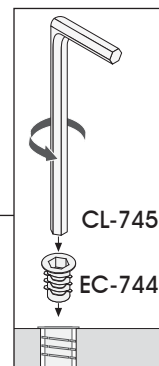
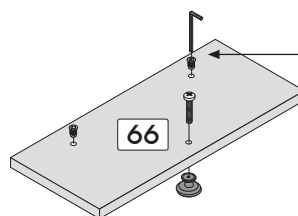
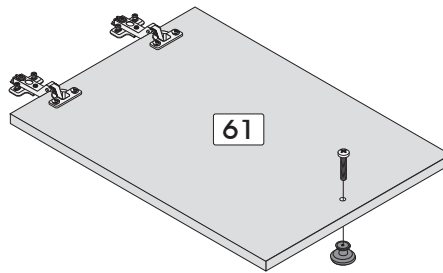
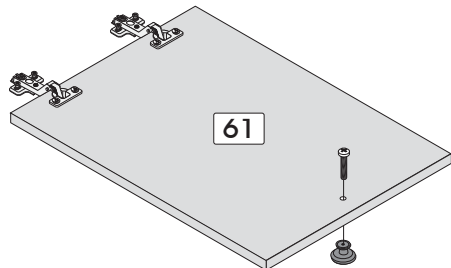
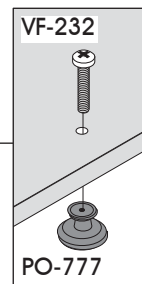
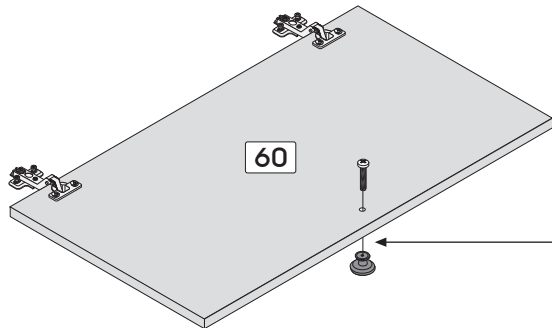
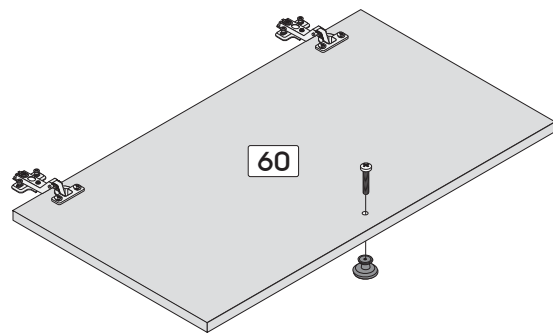
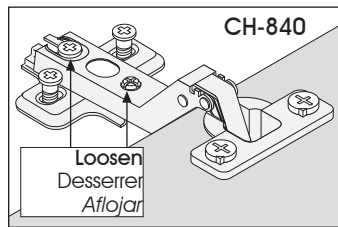

Code / Código

CH-840

PO-777

CL-745

EC-744

VF-232

Qty / Qté / Cant.

x 8

x 7

x 1

x 6

x 7

Drawers & Keyboard Shelf / Tiroirs et tablette à clavier / Cajónes y estante para teclado

**important / importante**

Drive the screw all the way in to install CO-843.  
 Vissez à fond avant d'installer la CO-843.  
 Atornille a fondo antes de instalar el CO-843.

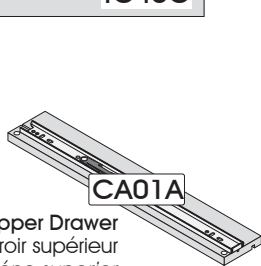
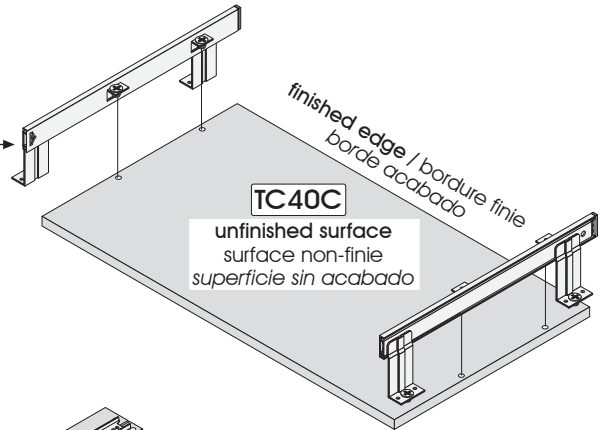
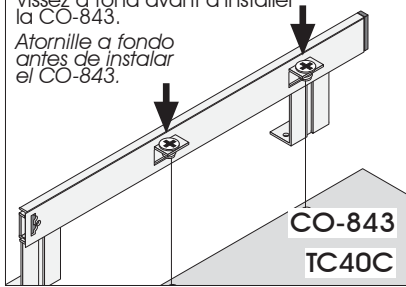

right side /Upper Drawer  
 côté droit / Tiroir supérieur  
 costado derecho / Cajón superior

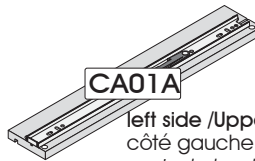

left side /Upper Drawer  
 côté gauche / Tiroir supérieur  
 costado izquierdo / Cajón superior

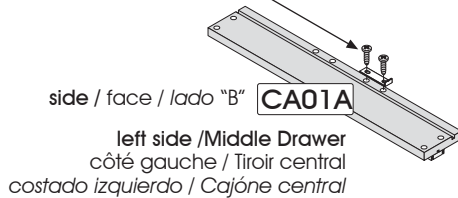
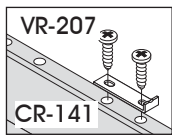

side / face / lado "B"  
 left side /Middle Drawer  
 côté gauche / Tiroir central  
 costado izquierdo / Cajón central



side / face / lado "A"  
 left side /Middle Drawer  
 côté gauche / Tiroir central  
 costado izquierdo / Cajón central

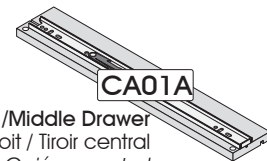

right side /Middle Drawer  
 côté droit / Tiroir central  
 costado derecho / Cajón central

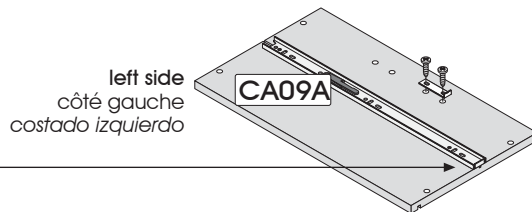
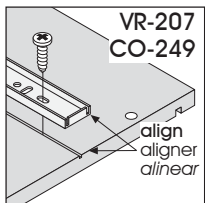

left side  
 côté gauche  
 costado izquierdo

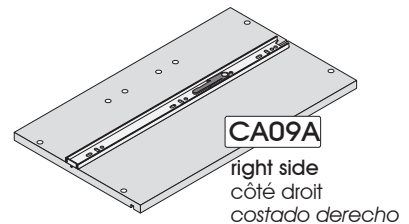

right side  
 côté droit  
 costado derecho

|                   |        |        |        |        |
|-------------------|--------|--------|--------|--------|
|                   |        |        |        |        |
| Code / Código     | CO-249 | CO-843 | CR-141 | VR-207 |
| Qty / Qté / Cant. | x 3    | x 1    | x 2    | x 22   |



# 12 ASSEMBLY / ASSEMBLAGE / ENSAMBLAJE

## MIDDLE Drawer / Tiroir CENTRAL / Cajón CENTRAL

Assembling sequence  
 Séquence d'assemblage  
 Secuencia de ensamblaje  
 Parts / Pièces / Piezas:

CA05A CA01A CA01A + bottom / fond / fondo + CA05A 66

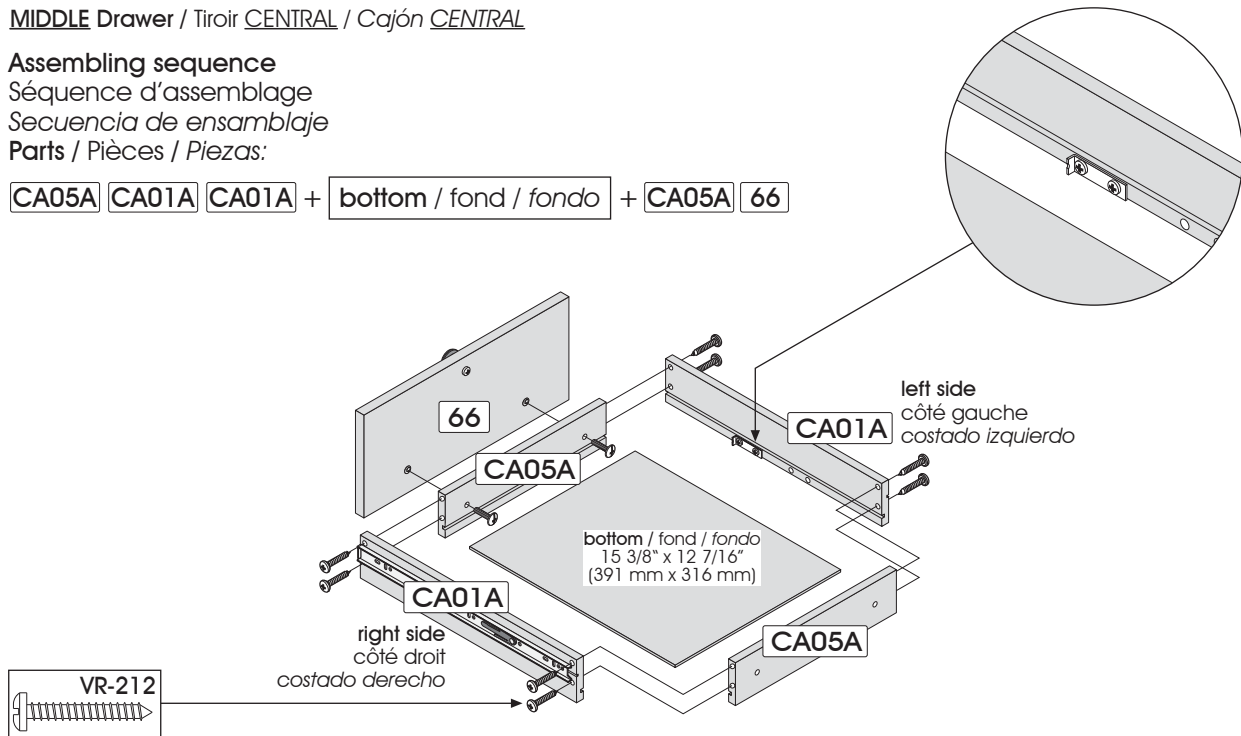

## UPPER Drawer / Tiroir SUPÉRIEUR / Cajón SUPERIOR

Assembling sequence  
 Séquence d'assemblage  
 Secuencia de ensamblaje  
 Parts / Pièces / Piezas:

CA05A CA01A CA01A +  
 bottom / fond / fondo + CA05A 66

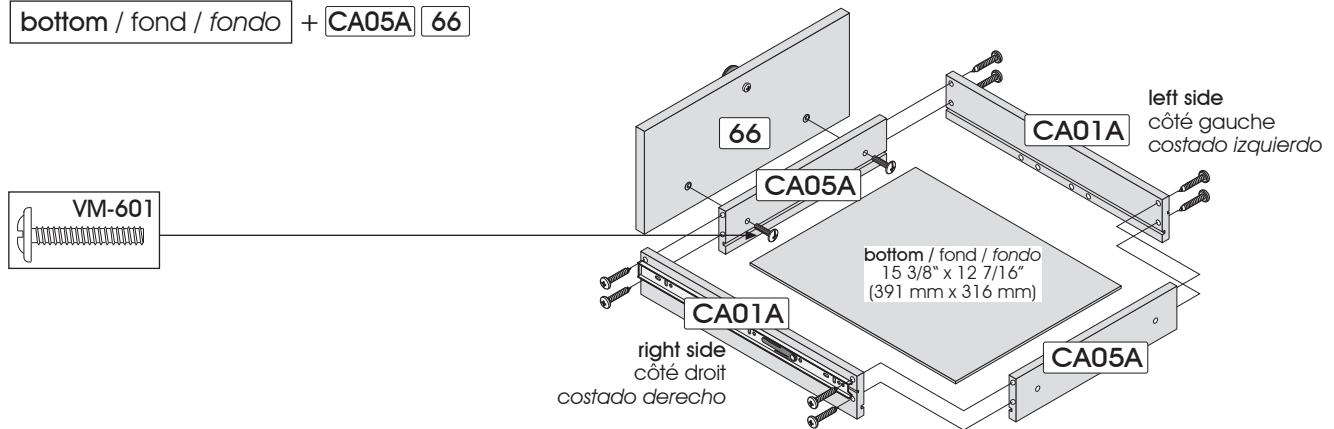

12

Code / Código

VM-601

VR-212

Qty / Qte / Cant.

x 4



x 16

SERVICE/SERVICIO: 1-888 8BESTAR (1-888 823-7827)

Assembling sequence  
 Séquence d'assemblage  
 Secuencia de ensamblaje  
 Parts / Pièces / Piezas:

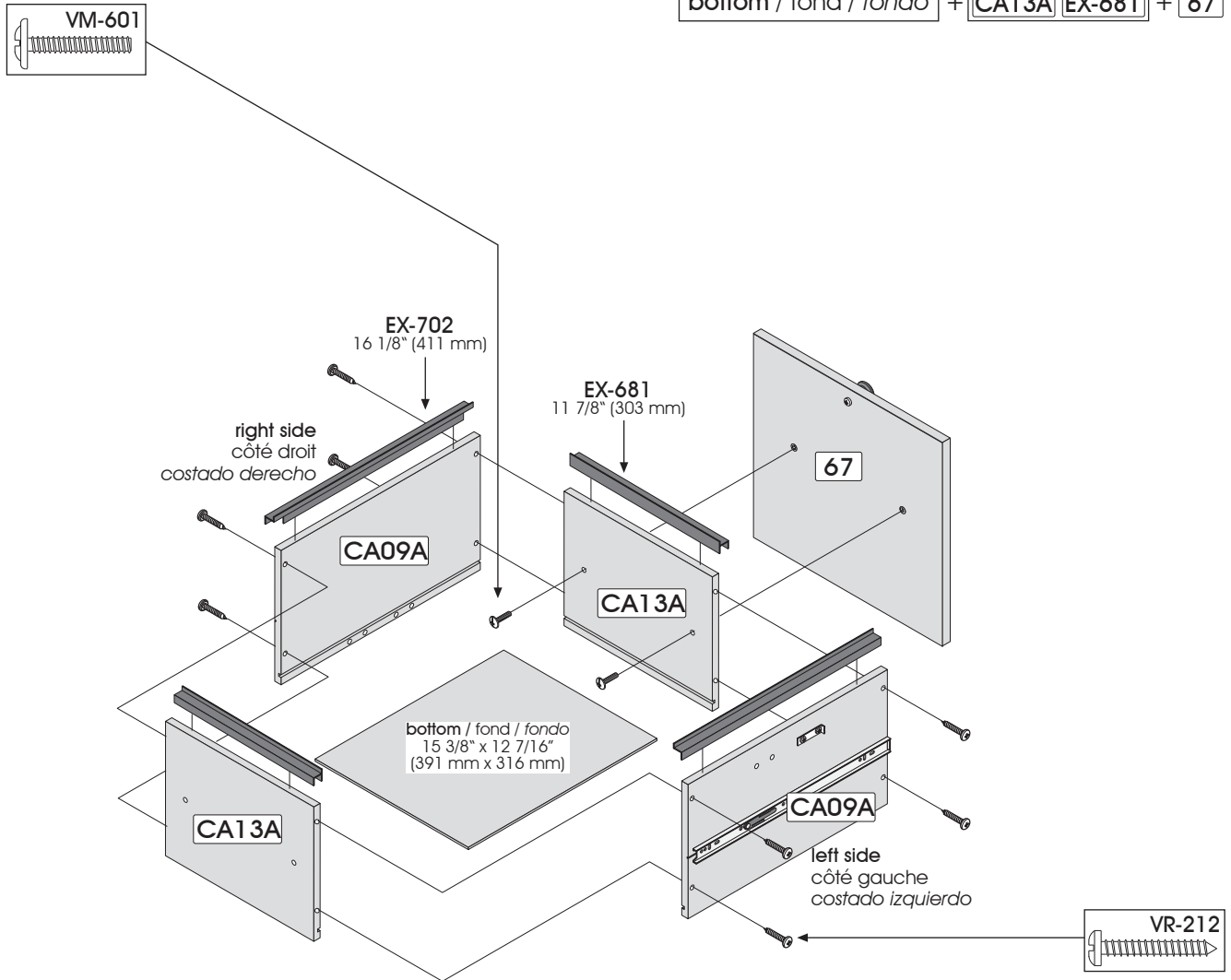
CA13A EX-681 + CA09A EX-702 + CA09A EX-702 +  
 bottom / fond / fondo + CA13A EX-681 + 67

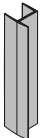
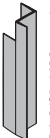

|                   |   |   |   |   |
|-------------------|---|---|---|---|
|                   |  |  |  |  |
| Code / Código     | EX-681  | EX-702  | VR-212  | VM-601  |
| Qty / Qté / Cant. | x 2   | x 2   | x 8   | x 2   |

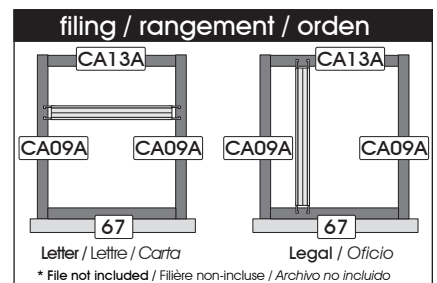

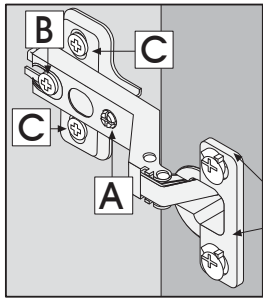

Use screw A for horizontal adjustment, screw B for depth adjustment and screws C for vertical adjustment.

Utilisez la vis A pour l'ajustement horizontal, les vis B pour l'ajustement en profondeur et les vis C pour l'ajustement vertical.

Utilice el tornillo A para realizar el ajuste horizontal, los tornillos B para el ajuste de profundidad y los tornillos C para el ajuste vertical.

To remove hinges (CH-840), start by loosening these two screws to free the locking system.

Pour enlever les pentures (CH-840), desserrez ces deux vis d'abord pour libérer le système de verrouillage.

Para retirar las bisagras (CH-840), afloje primero estos dos tornillos para liberar el sistema de fijación.

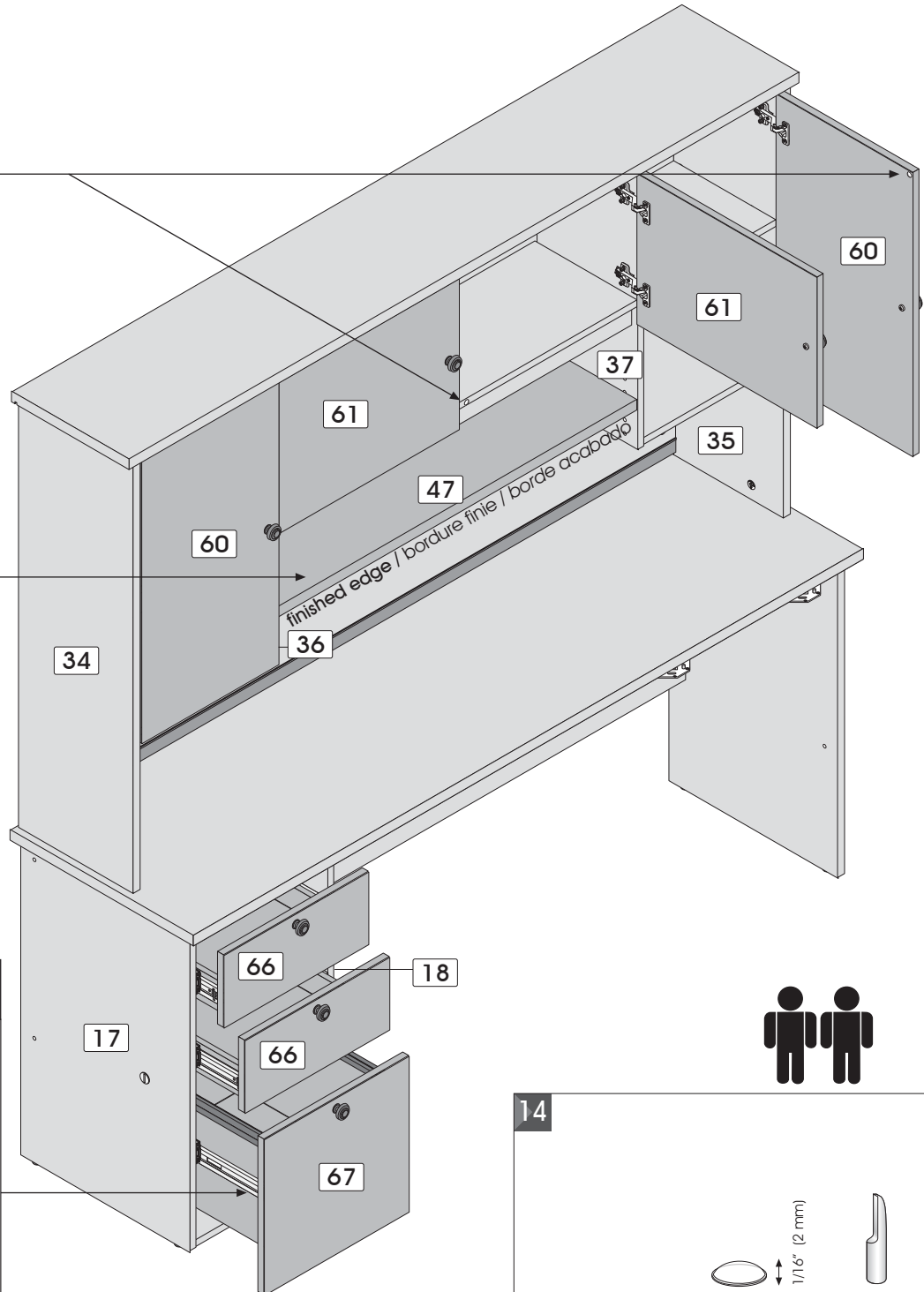
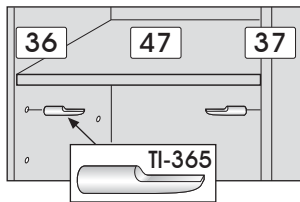

**important  
importante**

Ball bearings must be on front part of slider when installing drawers.  
Les roulements à billes doivent être sur la partie avant du coulisseau lors de l'installation des tiroirs.  
Los cojinetes de bolas deben ubicarse sobre la parte delantera de guía en el momento de instalar los cajones.



14

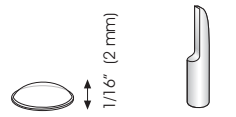

|                   |        |        |
|-------------------|--------|--------|
| Code / Código     | AM-182 | TI-365 |
| Qty / Qté / Cant. | x 4    | x 4    |

### Important/Importante

3 possibilities for left assembly / 3 possibilités pour l'assemblage gauche / 3 posibilidades para el ensamblaje izquierdo

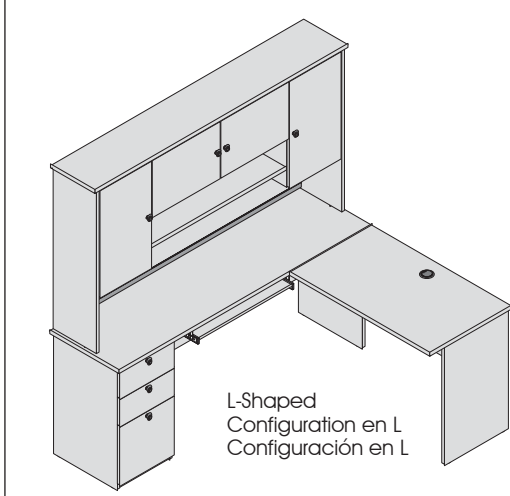

L-Shaped  
Configuration en L  
Configuración en L

For L-Shaped configuration, please refer to page 21  
Pour la configuration en L, référez-vous à la page 21  
Para la configuración en L, vea a la página 21

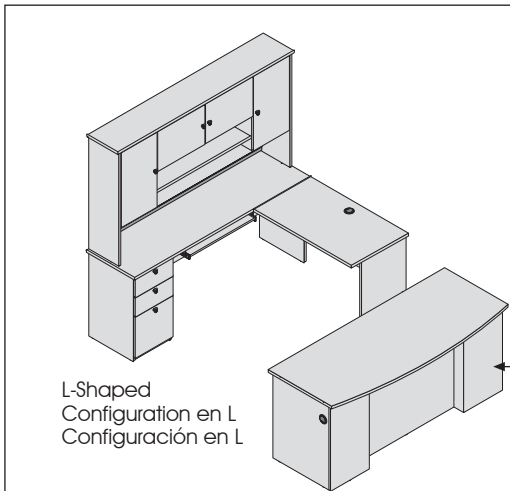

L-Shaped  
Configuration en L  
Configuración en L

not included with 81411-21-22  
non-inclus avec 81411-21-22  
no se incluye con 81411-21-22

For L-Shaped configuration, please refer to the page 21  
and to the instructions manual 81411-23.  
Pour la configuration en L, référez-vous à la page 21  
et au feuillet d'instructions 81411-23.  
Para la configuración en L,  
vea página 21 y el manual instrucciones 81411-23.

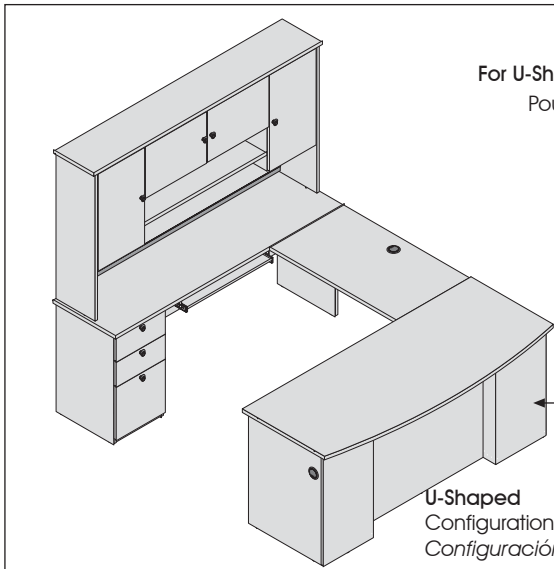

U-Shaped  
Configuration en U  
Configuración en U

For U-Shaped configuration, please refer to the instructions manual 81411-23.  
Pour la configuration en U, référez-vous au feuillet d'instructions 81411-23.  
Para la configuración en U, vea el manual instrucciones 81411-23.

not included with 81411-21-22  
non-inclus avec 81411-21-22  
no se incluye con 81411-21-22

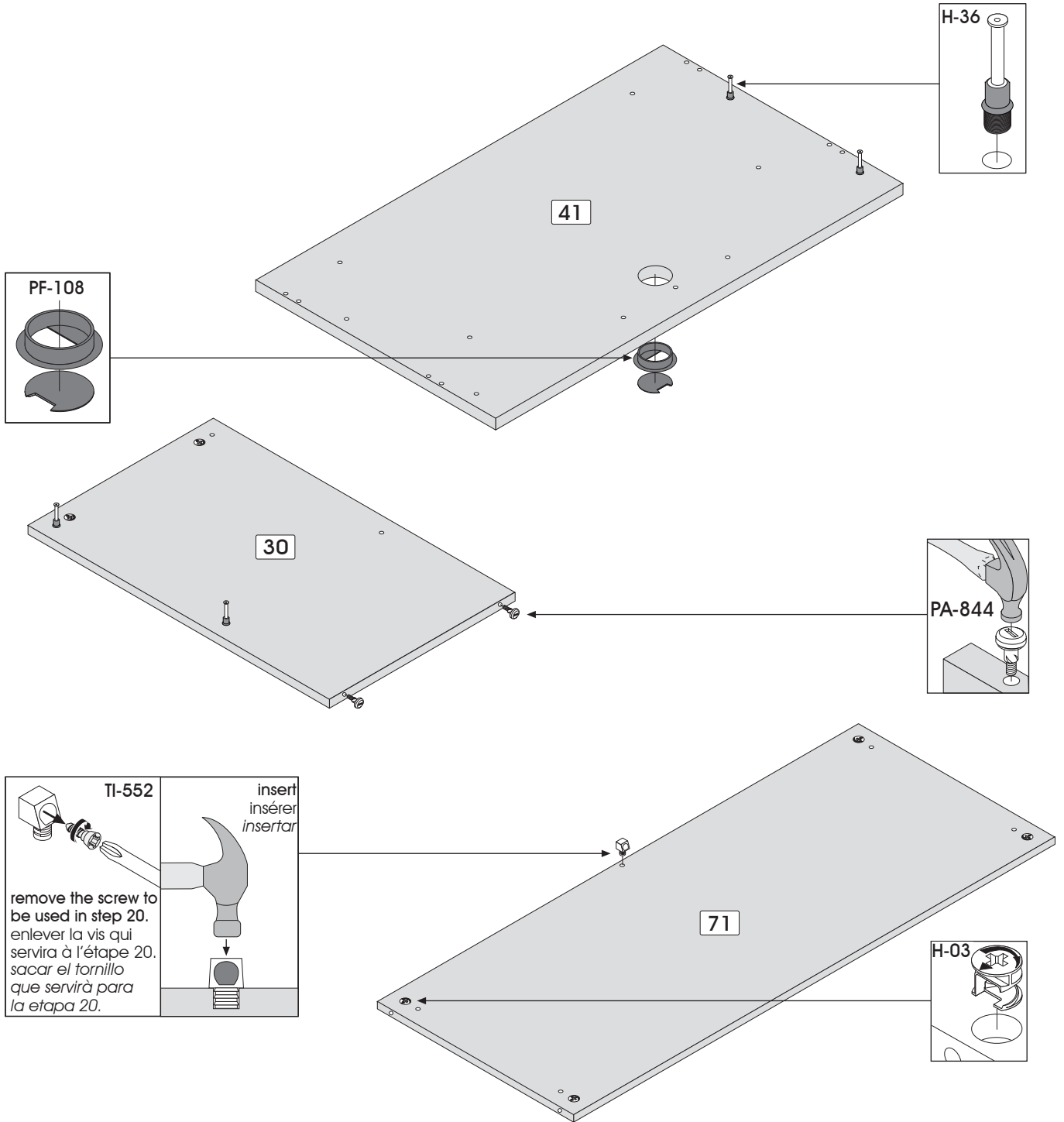

**TI-552**

remove the screw to be used in step 20.  
 enlever la vis qui servira à l'étape 20.  
 sacar el tornillo que servirá para la etapa 20.

insert  
 insérer  
 insertar

|                   |      |      |        |        |        |
|-------------------|------|------|--------|--------|--------|
|                   |      |      |        |        |        |
| Code / Código     | H-03 | H-36 | PA-844 | PF-108 | TI-552 |
| Qty / Qté / Cant. | x 6  | x 4  | x 2    | x 1    | x 1    |

Assemble upside down  
 Assemblez en position renversée  
 Realice el ensamblaje en posición invertida

Assembling sequence  
 Séquence d'assemblage  
 Secuencia de ensamblaje  
 Parts / Pièces / Piezas:

41 30 71

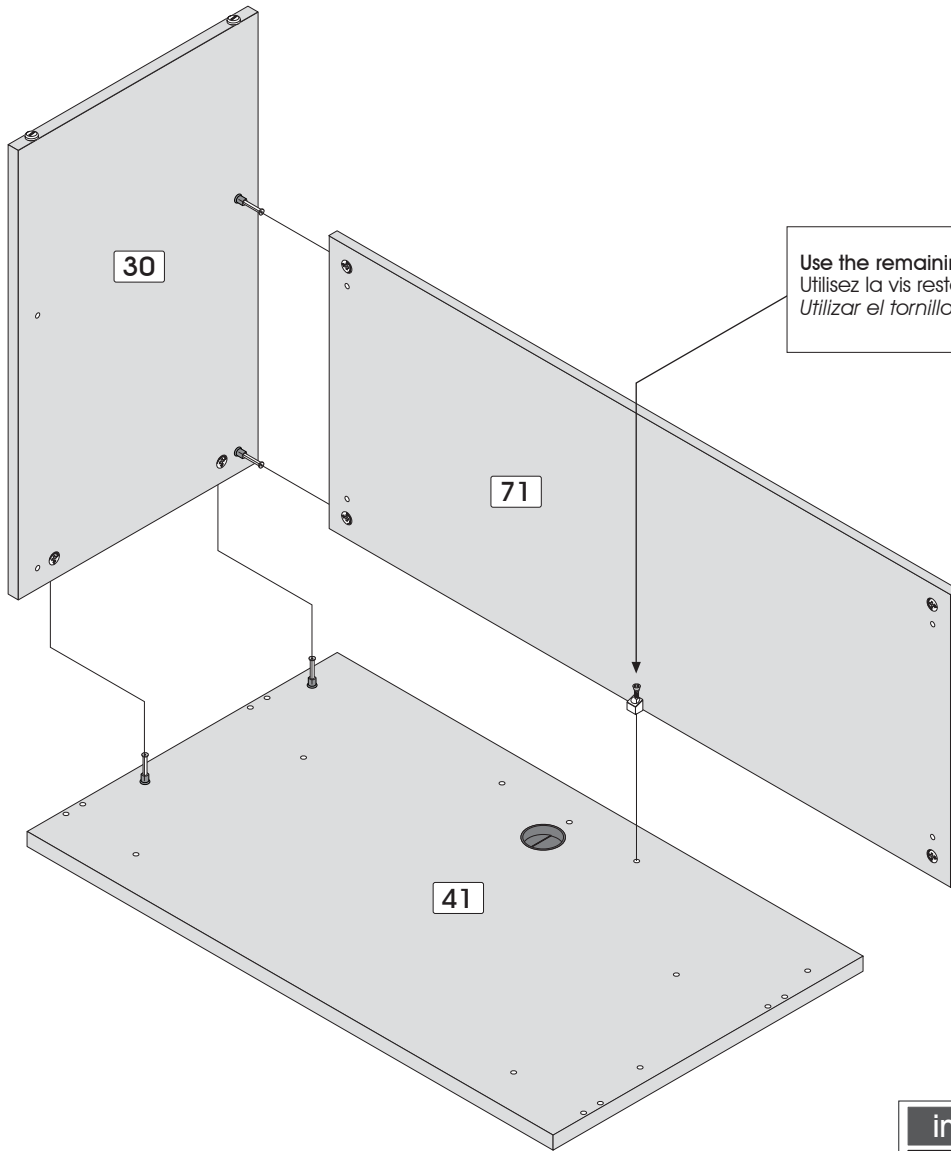

Use the remaining screw from step 16.  
 Utilisez la vis restante de l'étape 16.  
 Utilizar el tornillo restante de la etapa 16.

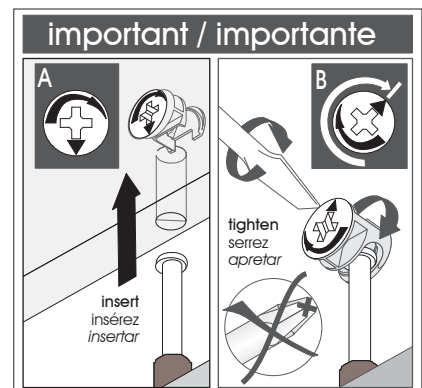
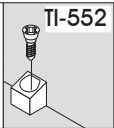

Assembling sequence  
 Séquence d'assemblage  
 Secuencia de ensablaje  
 Parts / Pièces / Piezas:

30 40 + EQ-143 + 41 71

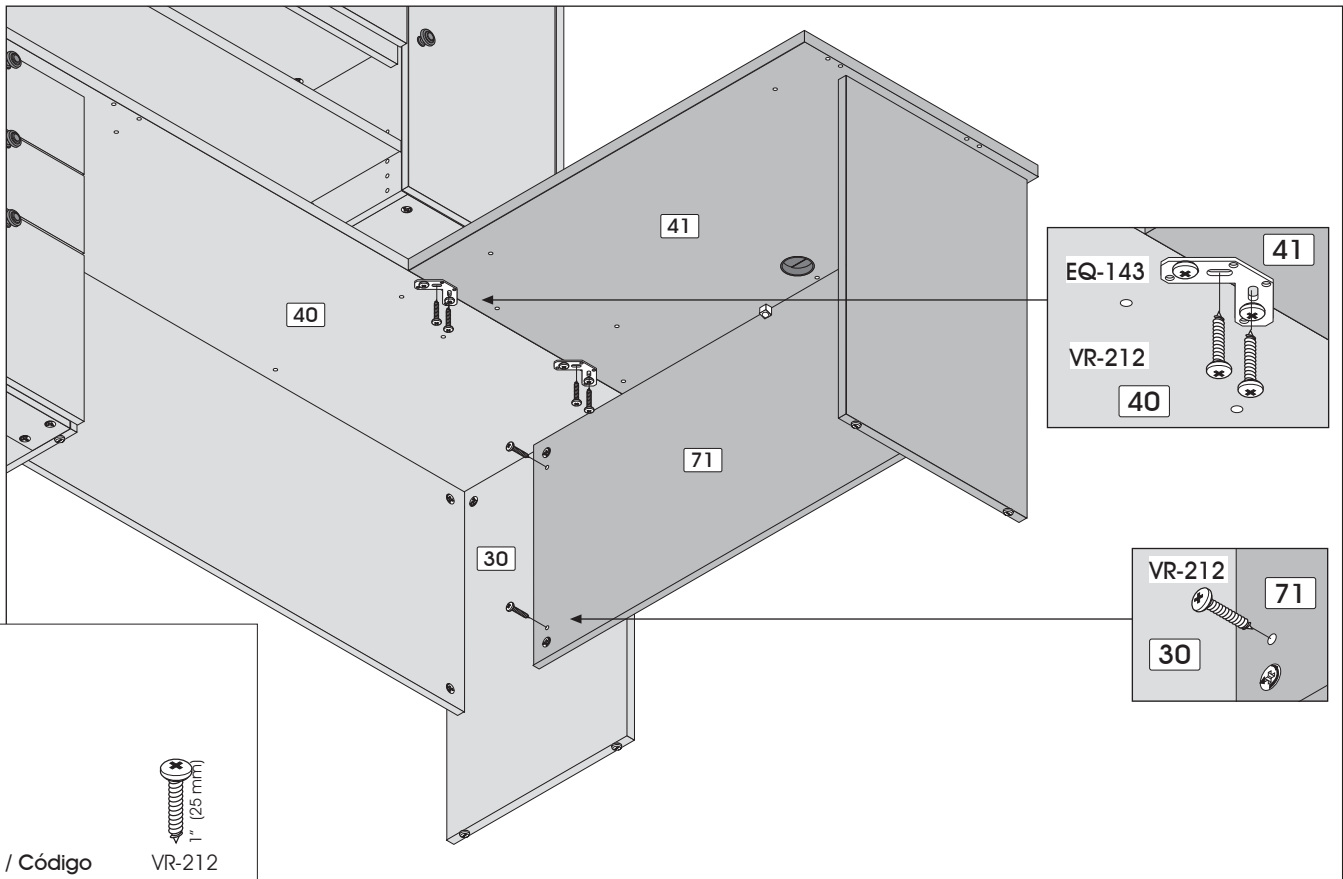
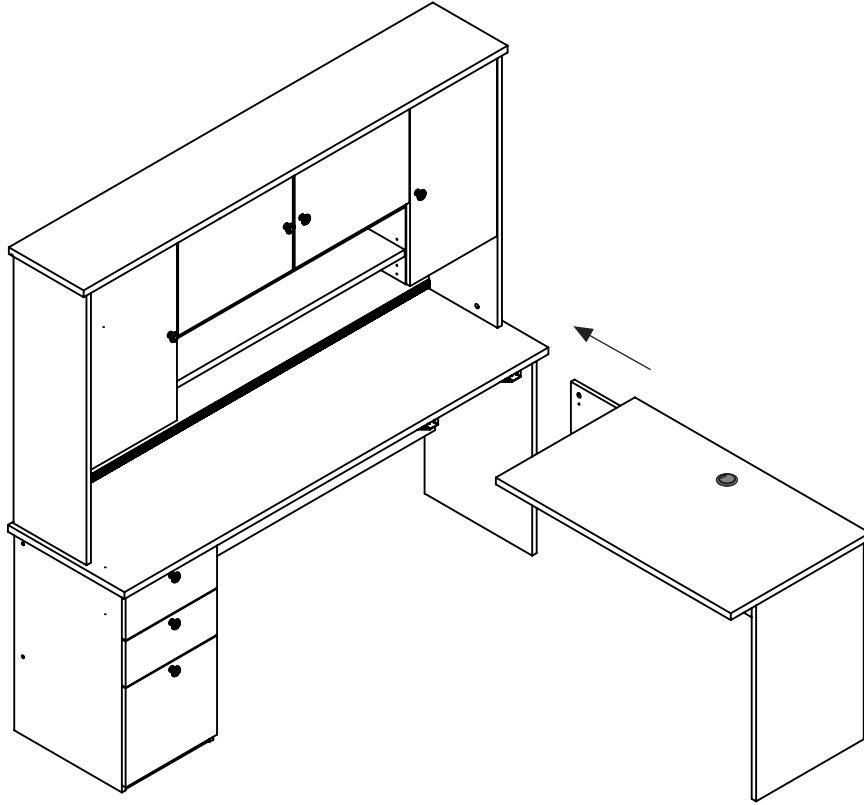

18

Code / Código VR-212  
 Qty / Qté / Cant. x 6

# 19 INSTALLATION / INSTALLATION / INSTALACIÓN

Keyboard Shelf / Tablette à clavier / Estante para teclado

**important / importante**

**2 possibilities / 2 possibilités / 2 posibilidades**

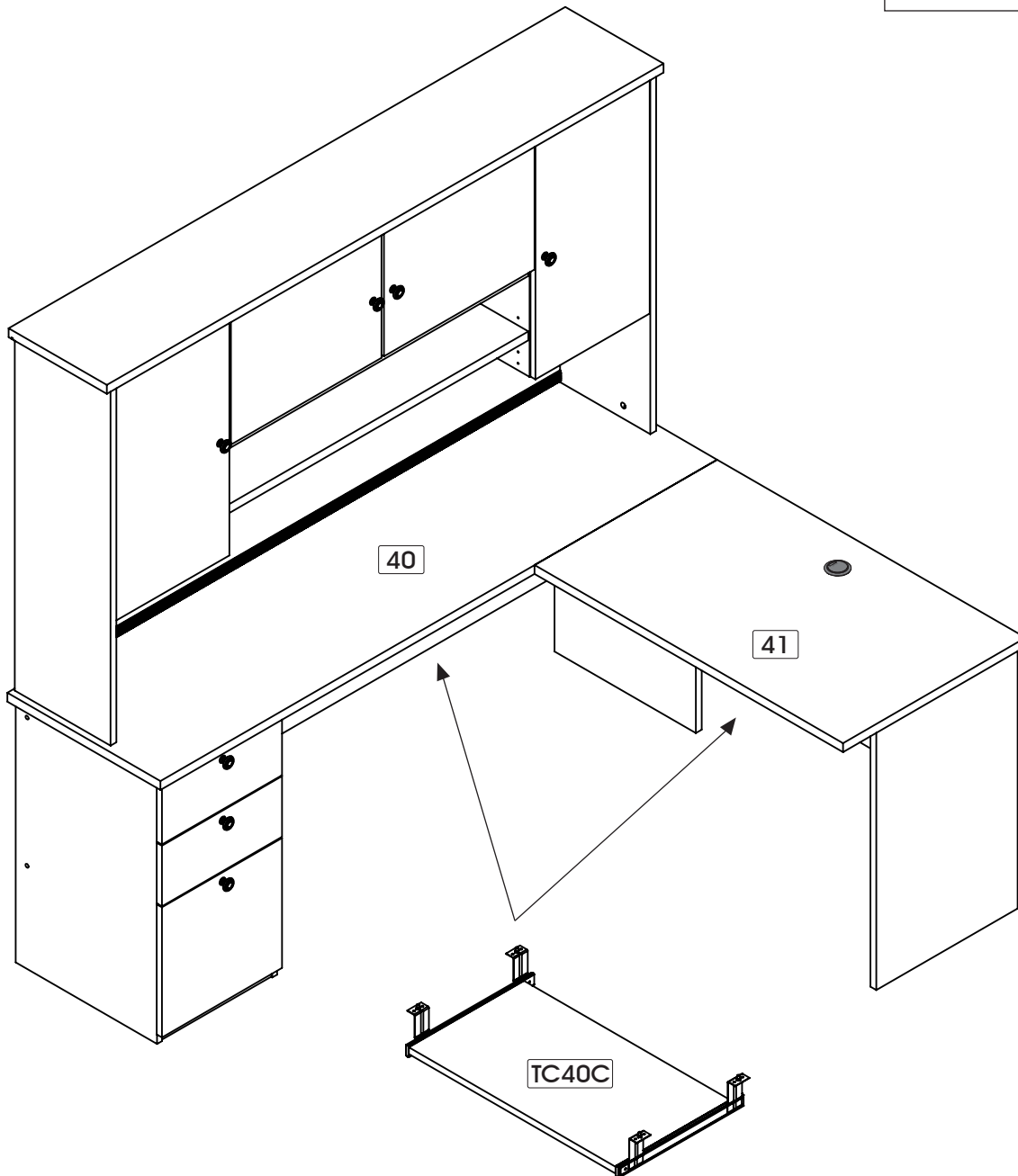
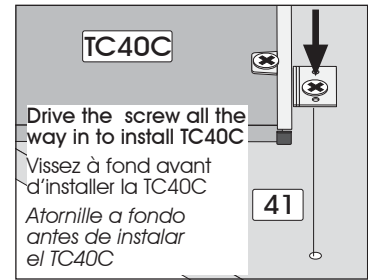



## Important/Importante

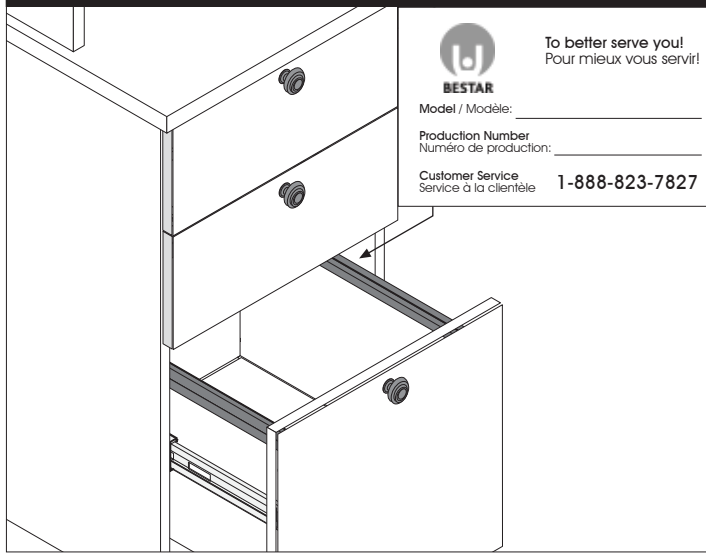

For future reference and to better serve you, please apply the self-adhesive sticker in an accessible space such as inside a drawer.

Pour mieux vous servir en cas de besoin, veuillez apposer l'autocollant dans un endroit facilement accessible tel que l'intérieur d'un tiroir.

*Para futura referencia y mejor servicio por favor pegue la etiqueta en un lugar accesible, por ejemplo al interior de un cajón.*

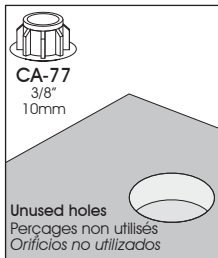
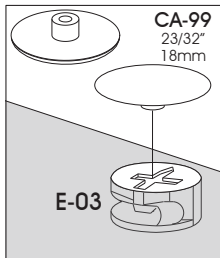

When you have completed the assembly of your new furniture, install plastic caps.

Lorsque vous avez complété l'assemblage de votre meuble, installez les capuchons de plastique.

Una vez que haya ensamblado el mueble, coloque los capuchones de plástico.

#### PRODUCT CARE / ENTRETIEN DU PRODUIT / MANTENIMIENTO DEL PRODUCTO

Avoid placing the furniture in the sunlight or near a source of heat. Use a soft dry cloth for dusting. To clean heavy dirt, use a cloth dipped in a solution of mild detergent and water. Avoid leaving wet objects on the surface or using commercial chemical cleaning products.

Évitez d'exposer le meuble au soleil ou près de toute source de chaleur. Pour le nettoyage, utilisez un chiffon doux et sec. Pour la grosse saleté, utilisez un chiffon humidifié avec un peu de détergent dilué dans l'eau. Évitez de laisser des objets mouillés sur la surface de votre meuble ou d'utiliser des nettoyants chimiques.

Evite exponer el mueble al sol o las fuentes de calor. Para limpiarlo, utilice un paño suave y seco. Para limpiar las manchas rebeldes, utilice un trapo húmedo con un poco de detergente diluido en agua. No deje objetos mojados encima del mueble ni utilice limpiadores que contengan productos químicos.

**CONGRATULATIONS! YOU ARE NOW THE OWNER OF A QUALITY PRODUCT**  
**FÉLICITATIONS! VOUS AVEZ MAINTENANT EN VOTRE POSSESSION UN PRODUIT DE QUALITÉ**  
**FELICITACIONES! AHORA ES USTED DUEÑO DE UN PRODUCTO DE CALIDAD.**

SERVICE/SERVICIO: 1-888 8BESTAR (1-888 823-7827)





**For more information or to discover our new products**

Pour toute information ou pour découvrir nos nouveaux produits  
*Para más información o descubrir nuestros nuevos productos*

[www.bestar.ca/site/en/register\\_your\\_product](http://www.bestar.ca/site/en/register_your_product)  
[www.bestar.ca/site/fr/enregistrement\\_de\\_produit](http://www.bestar.ca/site/fr/enregistrement_de_produit)

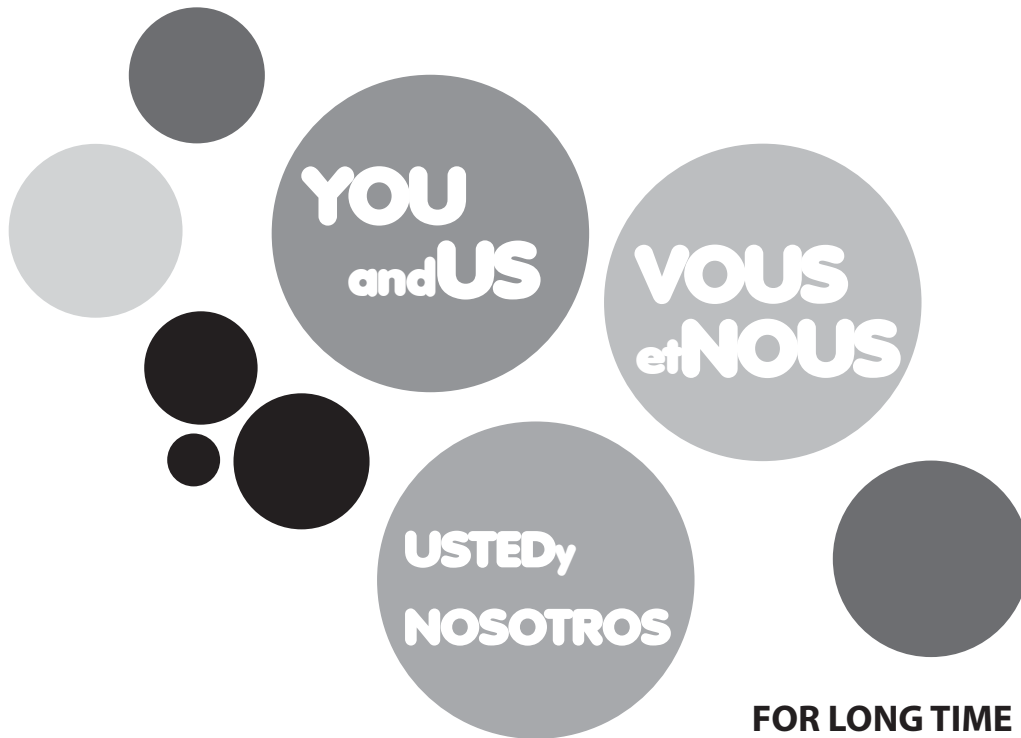

**FOR LONG TIME**  
**POUR LONGTEMPS**  
*POR MUCHO TIEMPO*

**OUR FURNITURE IS GUARANTEED FOR 10 YEARS. NO MATTER THE PROBLEM, OUR CUSTOMER SERVICE IS THERE FOR YOU. COMPLETE WORDING OF THE GUARANTEE AVAILABLE AT [WWW.BESTAR.CA/SITE/EN/WARRANTY/](http://WWW.BESTAR.CA/SITE/EN/WARRANTY/).**



**NOS MEUBLES SONT GARANTIS POUR 10 ANS. PEU IMPORTE LE PROBLÈME, N'HÉSITÉZ PAS À COMMUNIQUER AVEC NOTRE SERVICE À LA CLIENTÈLE. LIBELLÉ COMPLET DE LA GARANTIE DISPONIBLE AU [WWW.BESTAR.CA/SITE/FR/GARANTIE/](http://WWW.BESTAR.CA/SITE/FR/GARANTIE/).**

***NUESTROS MUEBLES TIENEN UNA GARANTÍA DE 10 AÑOS. NO IMPORTA EL PROBLEMA, COMUNIQUE CON NUESTRO SERVICIO A LA CLIENTELA. LA REDACCIÓN COMPLETA DE LA GARANTÍA ES DISPONIBLE A [WWW.BESTAR.CA/ES/GARANTIA/](http://WWW.BESTAR.CA/ES/GARANTIA/).***



**The new logo shows an open and radiant person. It also evokes the past of BESTAR, the fact that we were the first manufacturer of ready-to-assemble furniture to design U-Shape furniture. Finally, if you take the logo in its simplest form, it shows that BESTAR is there for its employees, for its customers and for its consumers, "BESTAR is there for you (U)".**  
Le nouveau logo illustre un personnage ouvert et rayonnant. Il évoque également le passé de BESTAR qui fut le premier fabricant de meubles prêt-à-assembler à concevoir des bureaux en forme de «U». Finalement, si on prend le logo sous sa forme la plus simple, il rappelle que BESTAR est présent pour ses employés, ses clients et ses consommateurs.  
*El logotipo ilustra un personaje abierto y radiante. El evoca el pasado igualmente, porque Bestar es el primer fabricante de muebles listos a ensamblar que concibió los escritorios en forma de "U". Finalmente, si llevamos el logotipo a su forma más sencilla, nos recuerda que Bestar está presente para sus empleados, colegas y clientes. "BESTAR está aquí para USTED (U)".*