



MODEL: MODÈLE: MODELO 81411-2375

SECRET MAPLE & CHOCOLATE : ÉRABLE SECRET ET CHOCOLAT : ARCE SECRETO Y CHOCOLATE
WWW.BESTAR.CA : 1-888-8BESTAR (1 888 823-7827)

81411-2339

BORDEAUX & GRAPHITE : BORDEAUX ET GRAPHITE : BURDEOS Y GRAFITO
WWW.BESTAR.CA : 1-888-8BESTAR (1 888 823-7827)

LEFT ASSEMBLY
INSTRUCTIONS

INSTRUCTIONS
D'ASSEMBLAGE GAUCHE

INSTRUCCIONES DE
ENSAMBLAJE IZQUIERDO

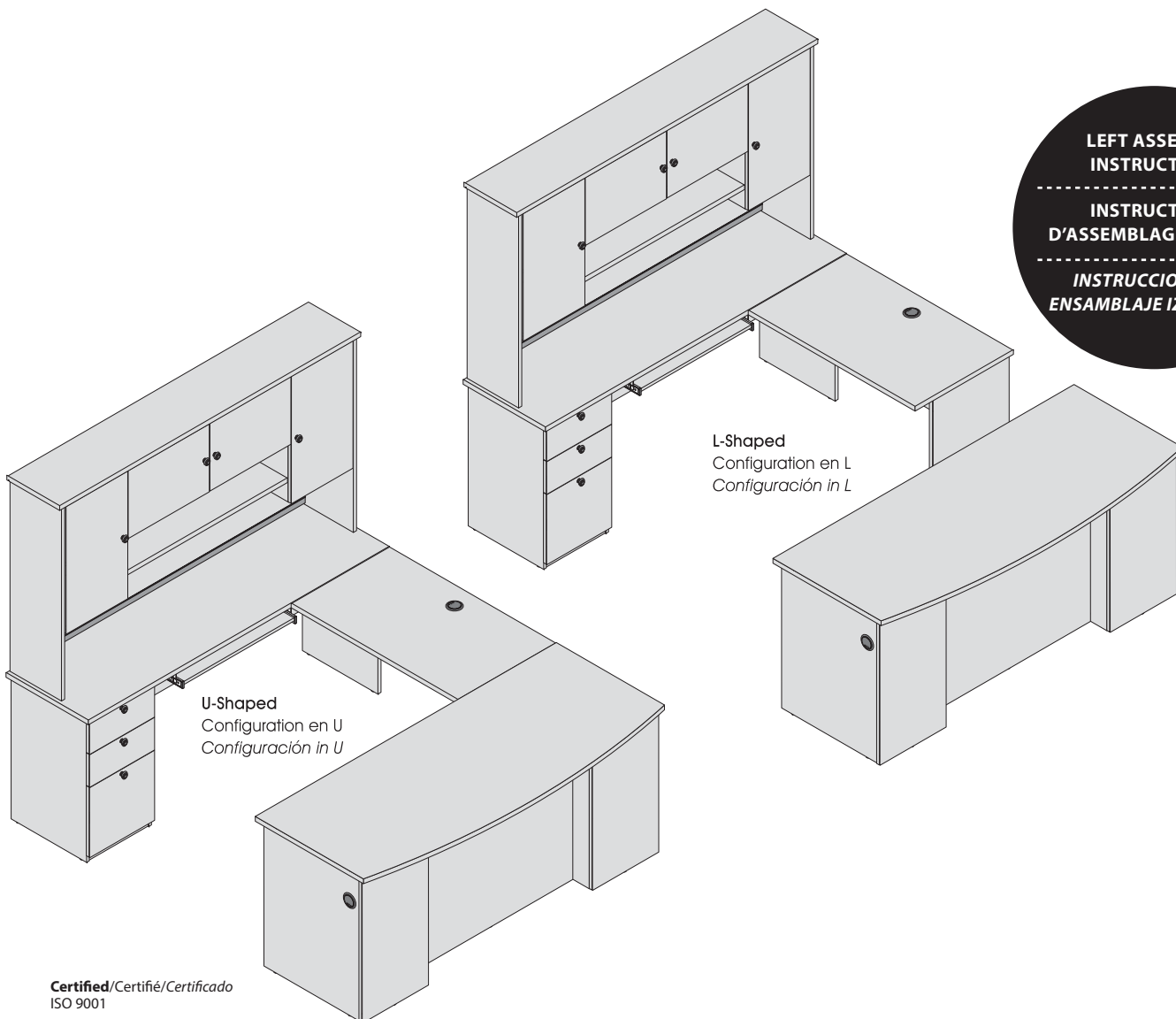





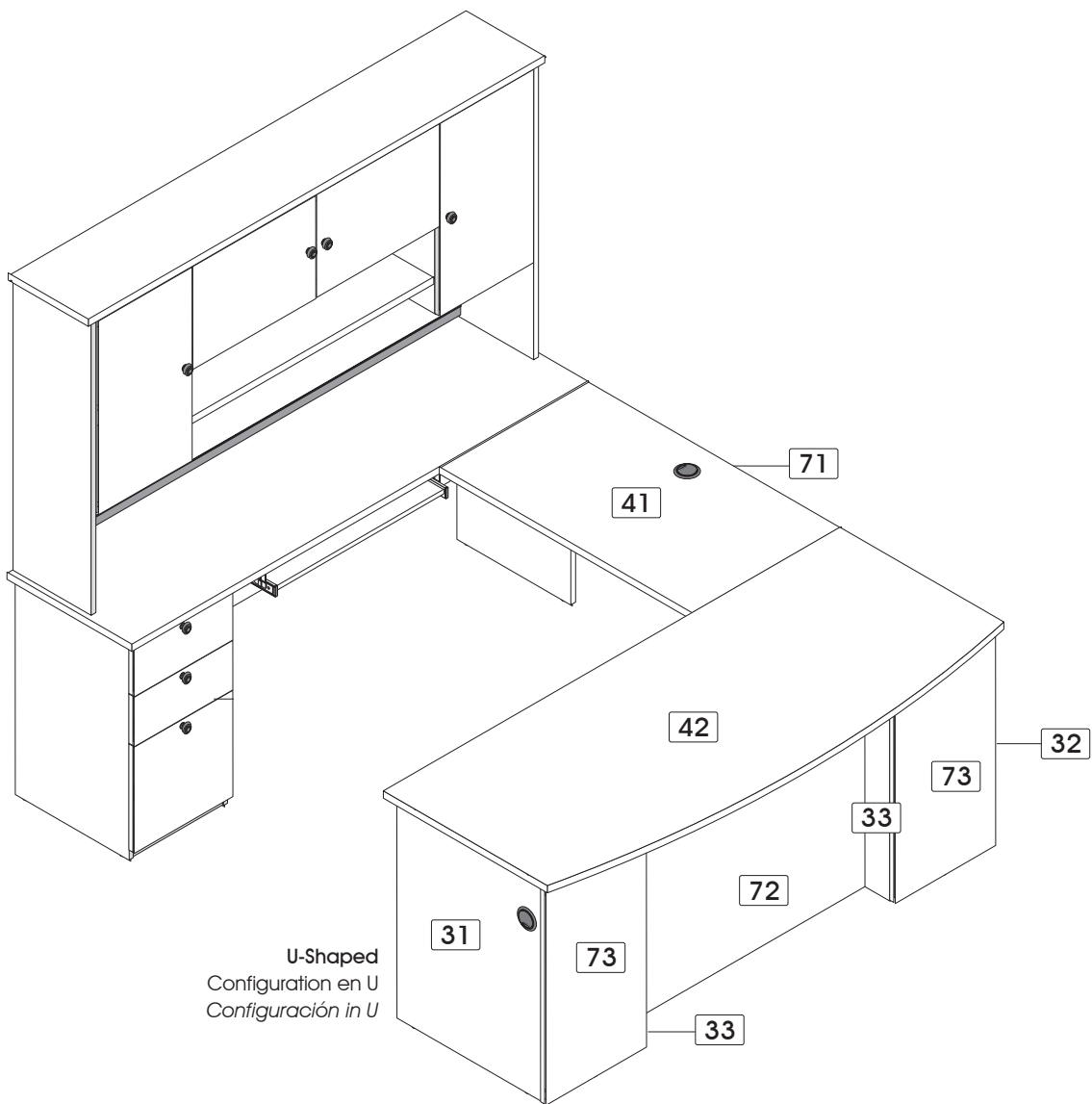

PARTS / PIÈCES / PIEZAS

CODE / CÓDIGO	QTY / QTÉ / CANT.	CODE / CÓDIGO	QTY / QTÉ / CANT.	CODE / CÓDIGO	QTY / QTÉ / CANT.	CODE / CÓDIGO	QTY / QTÉ / CANT.
31	1	33	2	72	1	73	2
32	1	42	1				

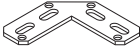

U-Shaped
 Configuration en U
 Configuración in U

▶ **HARDWARES / QUINCAILLERIES / QUINCALLAS**

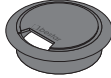
CODE / CÓDIGO	QTY / QTÉ / CANT.	CODE / CÓDIGO	QTY / QTÉ / CANT.	CODE / CÓDIGO	QTY / QTÉ / CANT.	CODE / CÓDIGO	QTY / QTÉ / CANT.
CA-99 	18	H-03 	18	PA-844  1" (25 mm)	7	VR-212  1" (25 mm)	10
EQ-143 	2	H-36 	18	PF-108 	2		

▶ **REAL SIZE / GRANDEUR RÉELLE / TAMAÑO REAL**

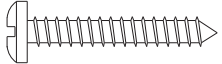
CODE / CÓDIGO	QTY / QTÉ / CANT.	CODE / CÓDIGO	QTY / QTÉ / CANT.
VR-212  1" (25 mm)	10		

▶ **PROBLEMS OR INFORMATION**

POUR TOUT PROBLÈME OU INFORMATION
PROBLEMAS O INFORMACIÓN

www.bestar.ca
1888 823-7827

▶ IMPORTANT NOTICE / NOTE IMPORTANTE / NOTA IMPORTANTE

Duly complete the self-adhesive sticker. / Assurez-vous de bien remplir l'auto-collant. / Asegúrese de completar correctamente la etiqueta.

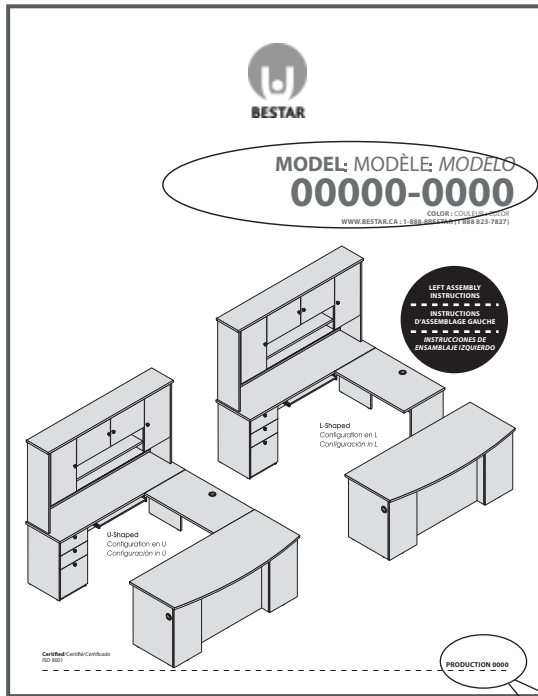

PRODUCTION 0000

BESTAR

To better serve you!
Pour mieux vous servir!

Model / Modèle: _____

Production Number
Numéro de production: _____

Customer Service
Service à la clientèle **1-888-823-7827**

Important/Importante

Please retain the self-adhesive sticker which you will install at page 26 of the instruction manual.

Conservez l'autocollant qui sera collé seulement à la page 26 du feuillet d'instructions.

Conserve la etiqueta que será pegada sólo en la página 26 de la hoja de instrucciones.

▶ IMPORTANT NOTICE / NOTE IMPORTANTE / NOTA IMPORTANTE

H-03

arrow
flèche
flecha

Insert the cam with the arrow pointing towards the hole in the edge.
Insérez la rondelle en pointant la flèche vers le trou de la bordure.
Inserte la arandela con la flecha apuntando hacia el orificio cercano al borde.

Main hardware system / Système de quincaillerie principal / Sistema principal de quincailla

1 insert / insérez / insertar

2 tools required / outils requis / herramientas necesarias

3 tighten / serrez / apretar

important
importante

How to remove a misplaced assembly bolt (H-36).
Comment retirer un boulon (H-36) mal situé.
Cómo retirar un perno (H-36) mal ubicado.

A turn / tournez / haga girar

B pull out / retirez / retire



SERVICE/SERVICIO: 1-888 8BESTAR (1-888 823-7827)

1 **HARDWARE INSTALLATION / INSTALLATION DES QUINCAILLERIES / INSTALACIÓN DE LAS QUINCALLAS**

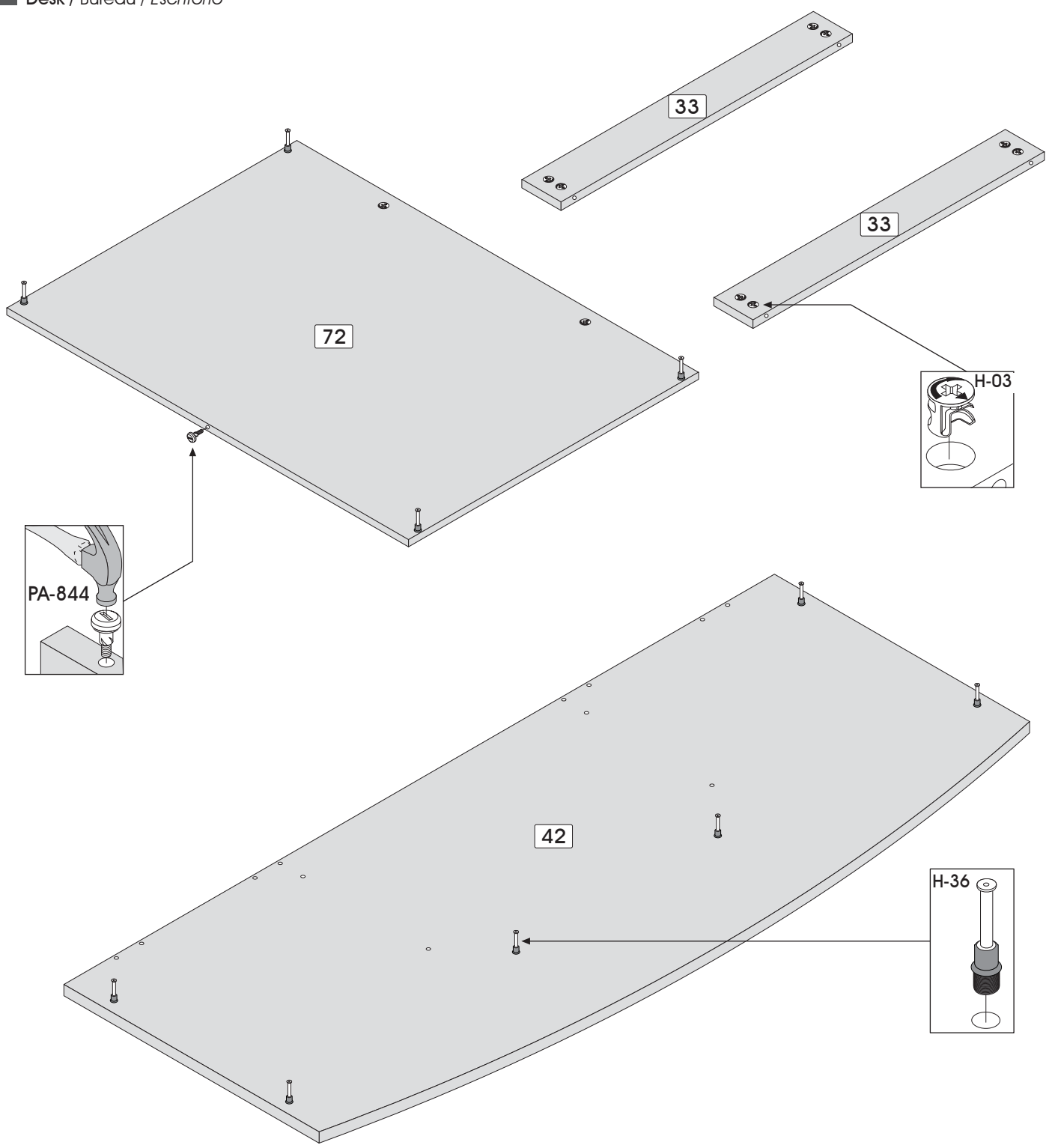
Desk / Bureau / Escritorio

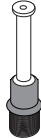

1



			
Code / Código	H-03	H-36	PA-844
Qty / Qté / Cant.	x 10	x 10	x 1

SERVICE/SERVICIO: 1-888 8BESTAR (1-888 823-7827)

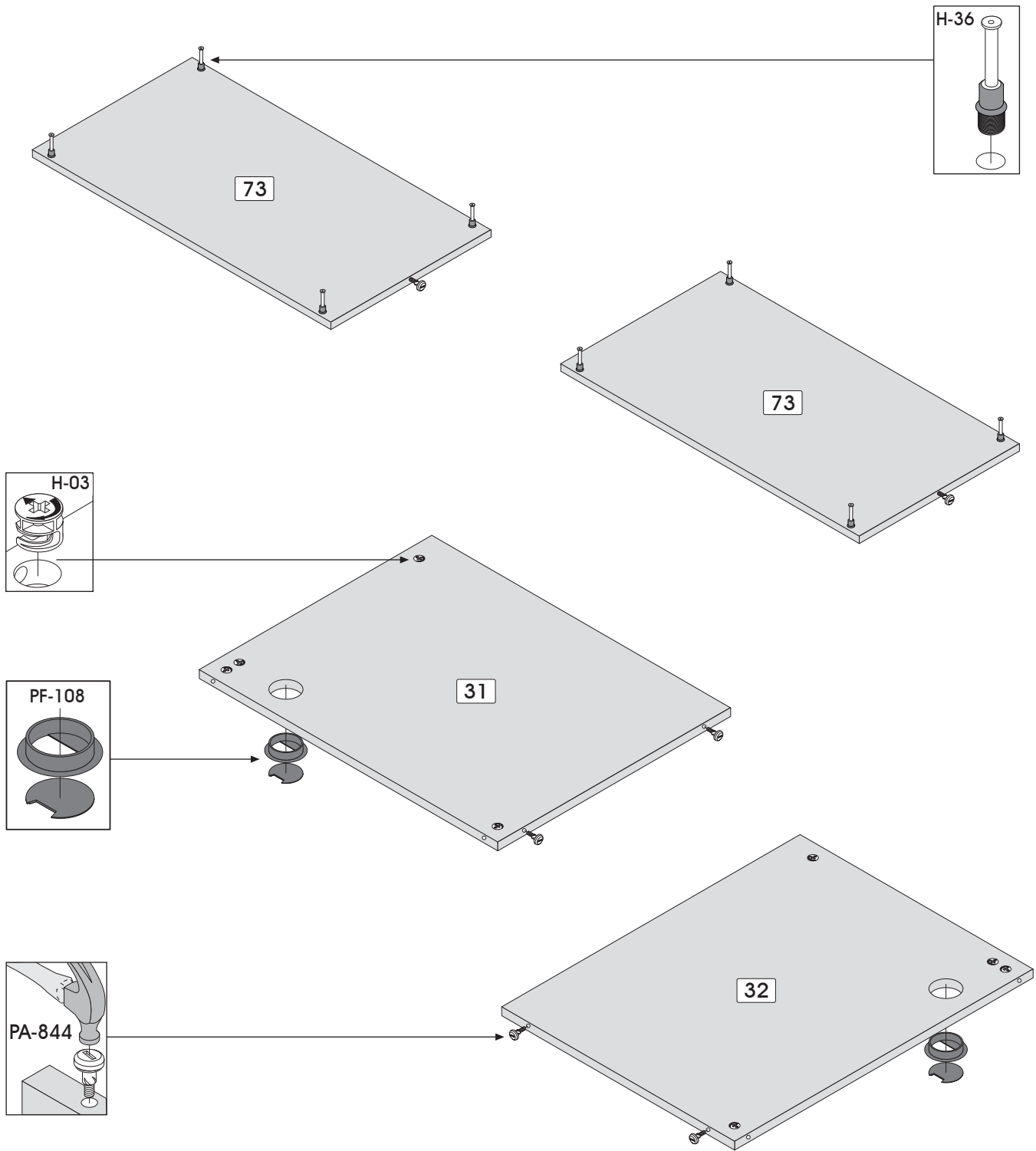
Desk / Bureau / Escritorio

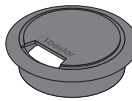

2

				
Code / Código	H-03	H-36	PA-844	PF-108
Qty / Qté / Cant.	x 8	x 8	x 6	x 2

SERVICE/SERVICIO: 1-888 8BESTAR (1-888 823-7827)

Desk / Bureau / Escritorio

Assemble upside down

Assemblez en position renversée

Realice el ensamblaje en posición invertida

Assembling sequence

Séquence d'assemblage

Secuencia de ensamblaje

Parts / Pièces / Piezas:

72 33 33 73 73 31 32 42

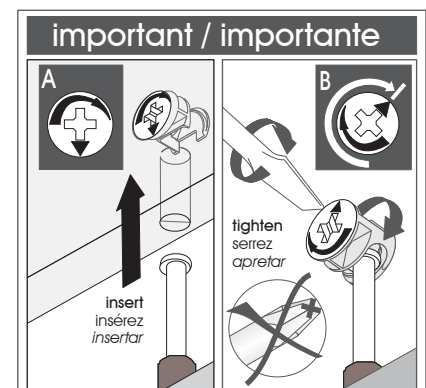
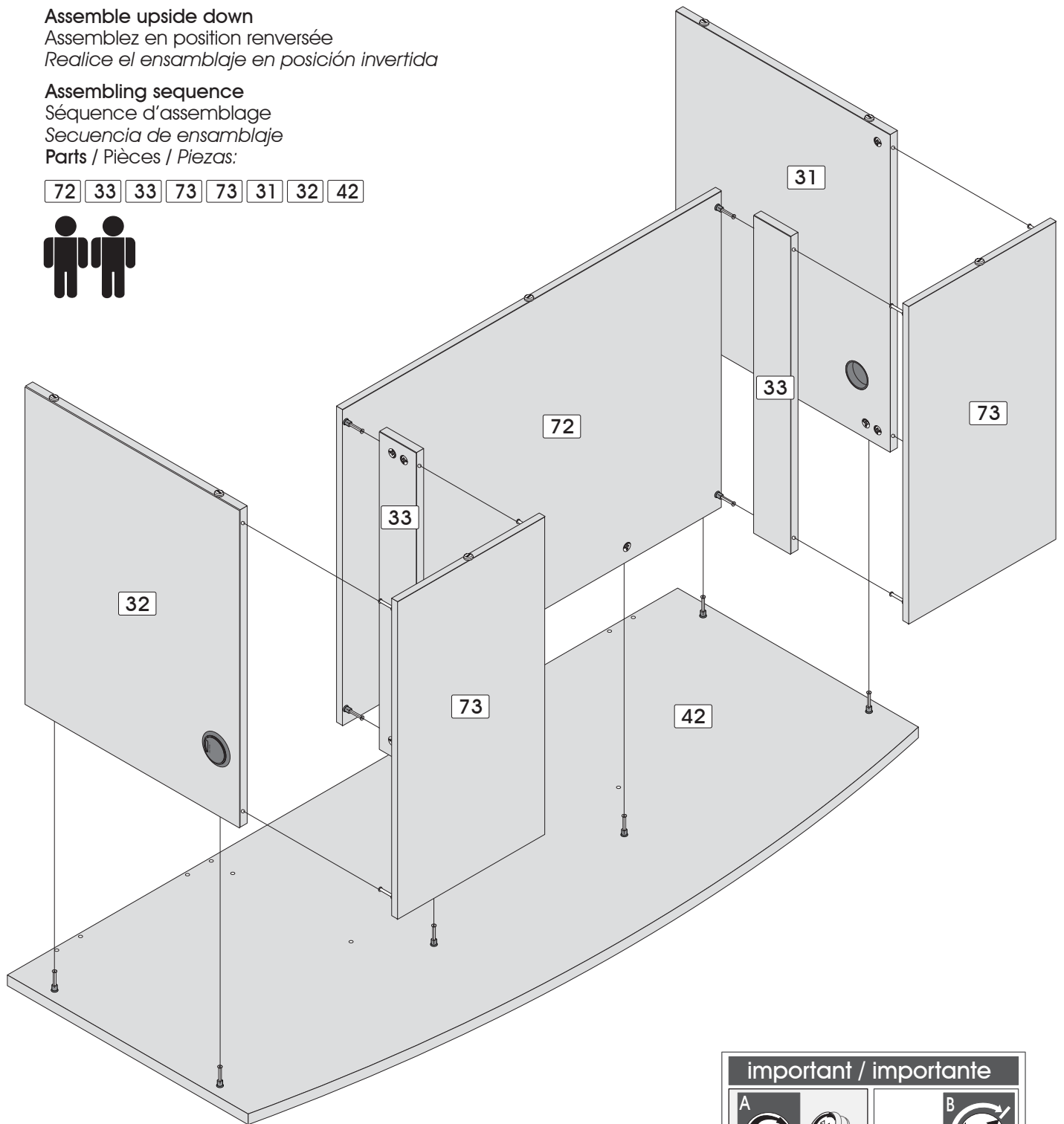

IMPORTANT/IMPORTANTE

2 possibilities for left assembly / 2 possibilités pour l'assemblage gauche / 2 posibilidades para el ensamblaje izquierdo

For L-Shape configuration, please refer to page 13.

Pour la configuration en L, référez-vous à page 13.

Para la configuración en L, vea la página 13.

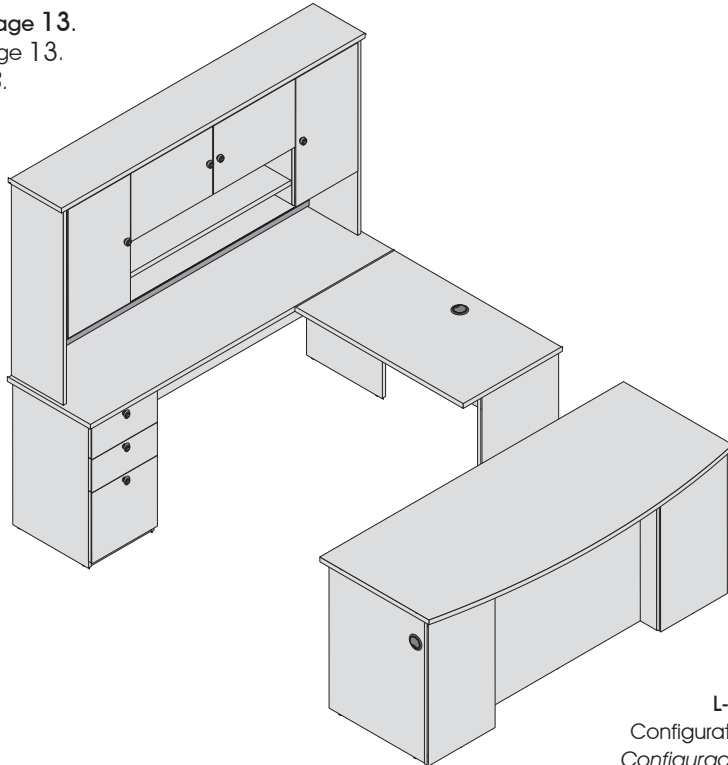

L-Shaped
Configuration en L
Configuración en L

For U-Shape configuration, please refer to pages 9-12.

Pour la configuration en U, référez-vous aux pages 9-12.

Para la configuración en U, vea las páginas 9-12.

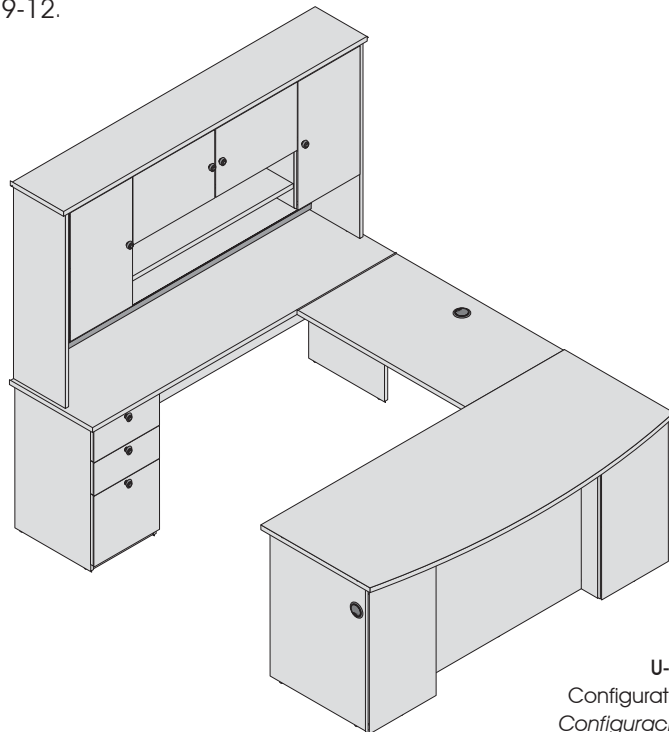

U-Shaped
Configuration en U
Configuración en U

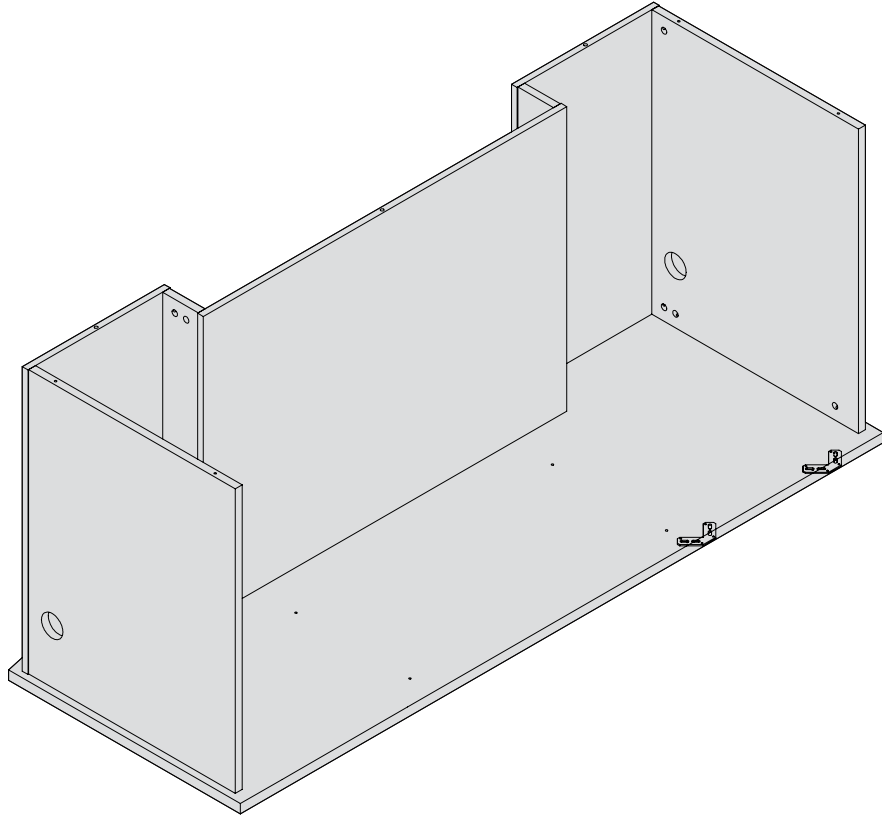

5

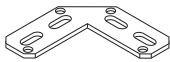

EQ-143

x 2



VR-212

x 4

Code / Código

Qty / Qté / Cant.

Bridge / Pont / Puente

IMPORTANT / IMPORTANTE

Use the parts and hardware remaining from 81411-21-22.
 Utilisez les pièces et quincailleries restants du 81411-21-22.
 Utilizar las piezas y quincaillas restantes de 81411-21-22.

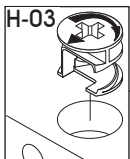
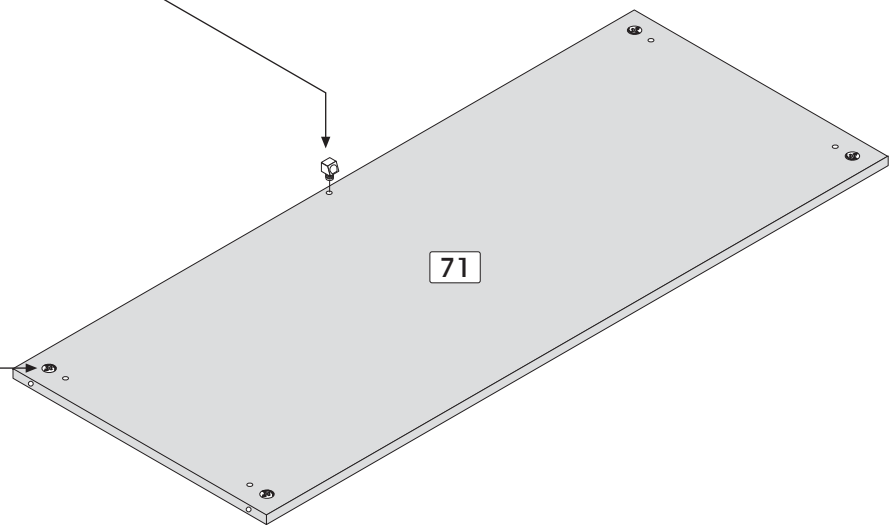
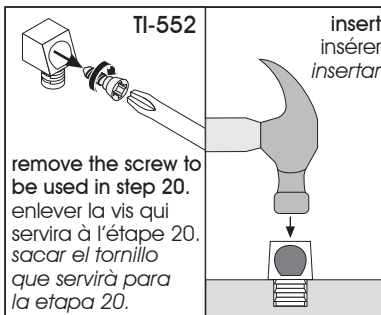
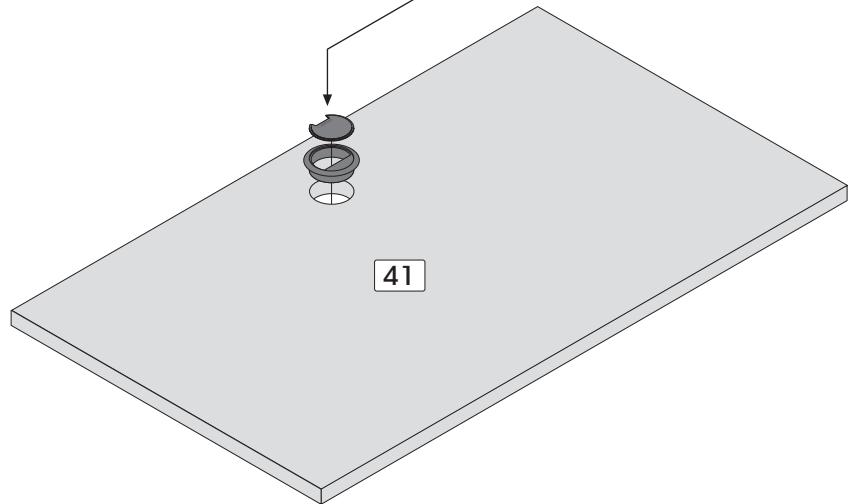
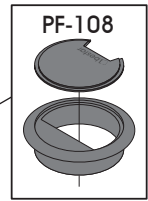

Code / Código

H-03

PF-108

TI-552

Qty / Qté / Cant.

x 4

x 1

x 1

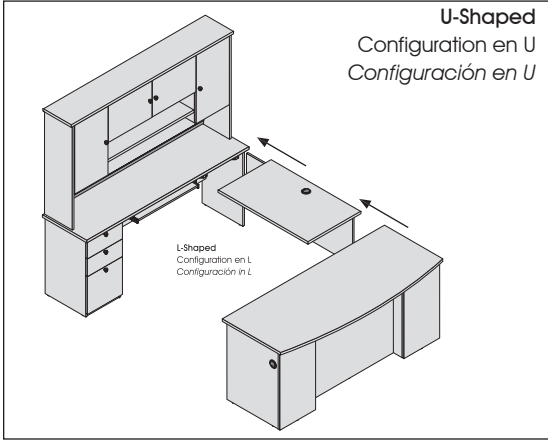

Assembling sequence
Séquence d'assemblage
Secuencia de ensamblaje
Parts / Pièces / Piezas:

30 40 + EQ-143 + 32 42
+ EQ-143 + 41 71



Use the remaining screw from step 16.
Utilisez la vis restante de l'étape 16.
Utilizar el tornillo restante de la etapa 16.

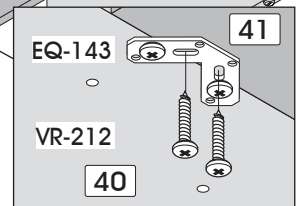
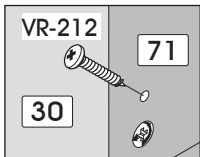
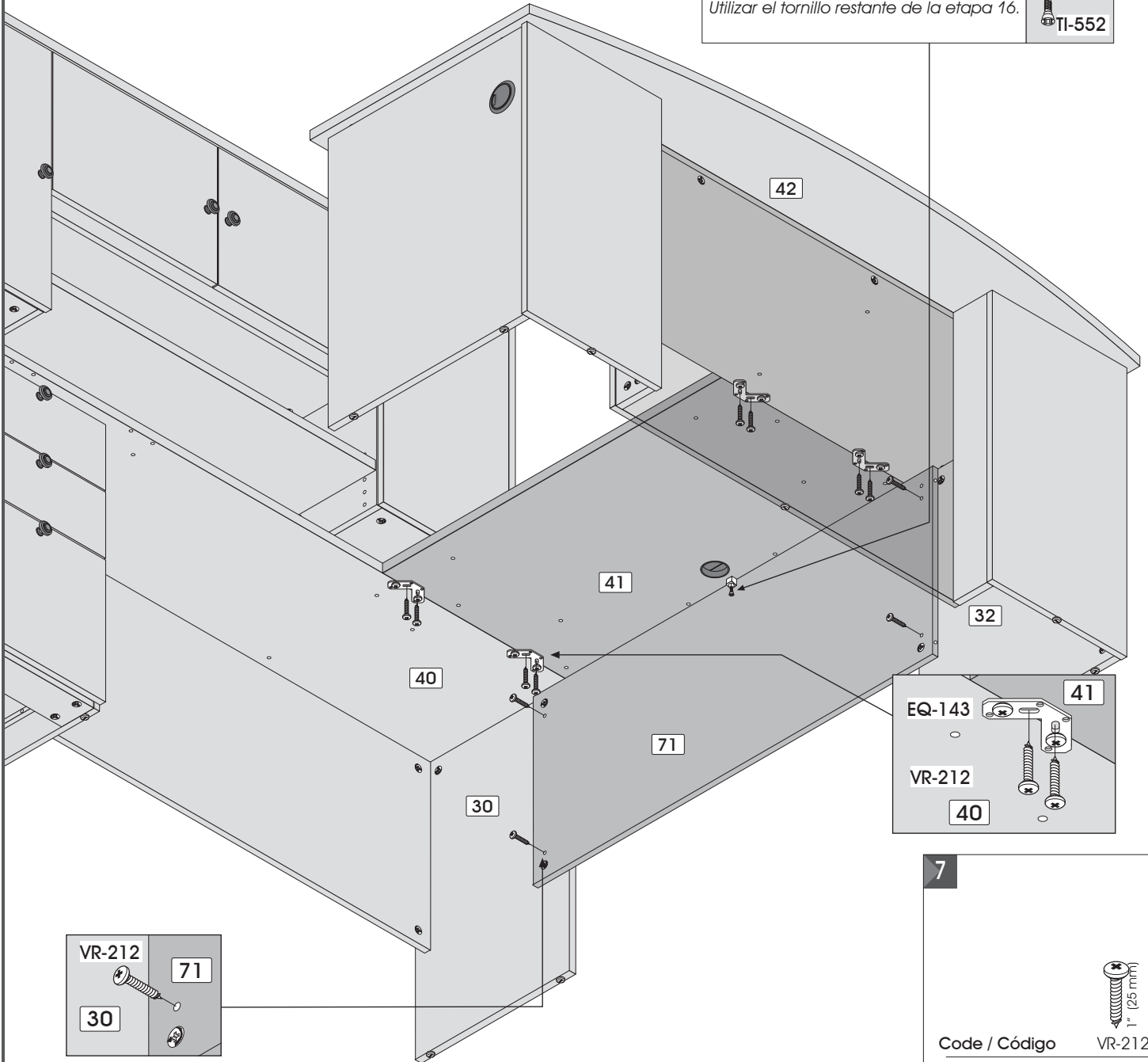
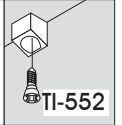

7

Code / Código VR-212
Qty / Qté / Cant. x 12

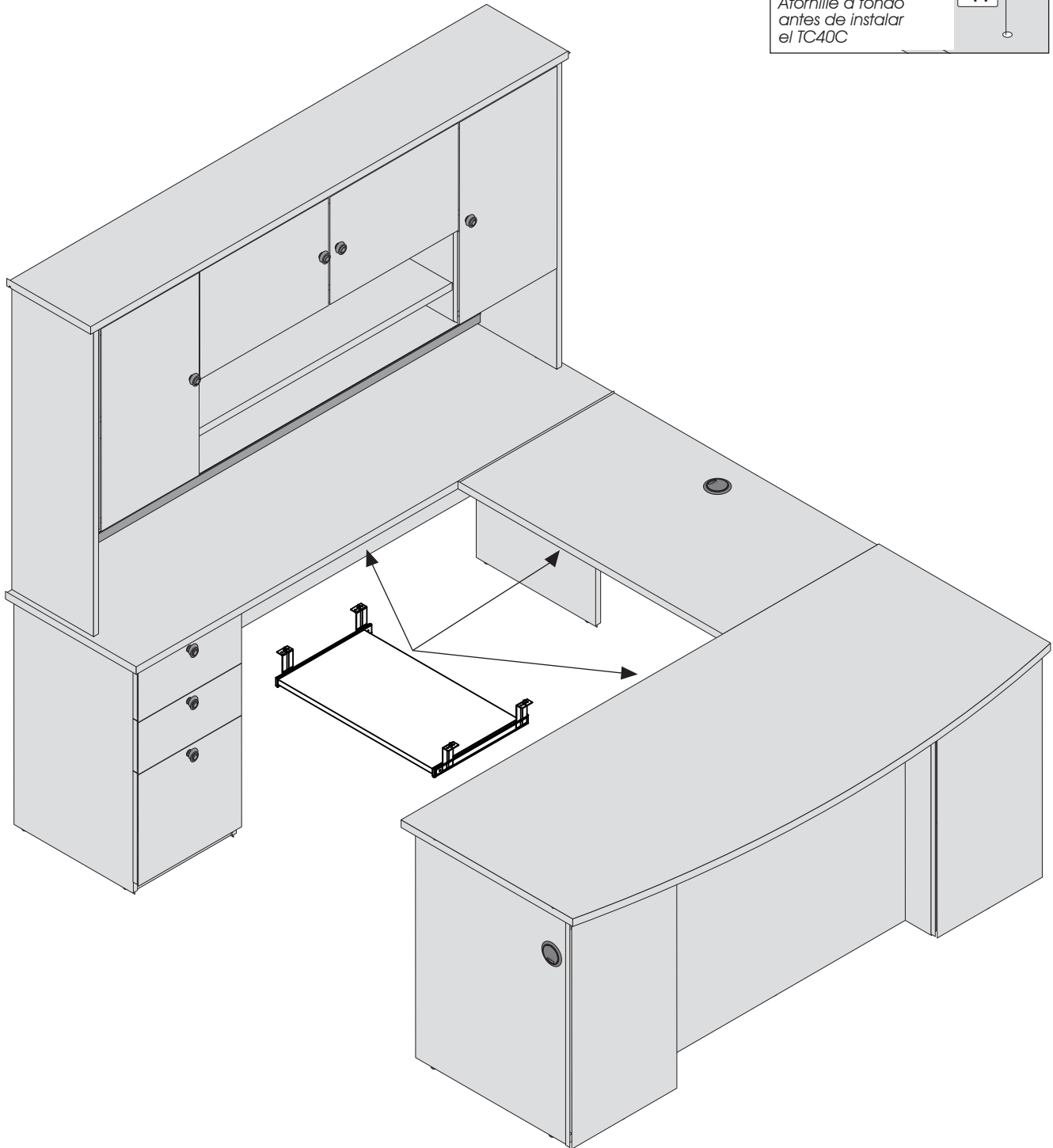
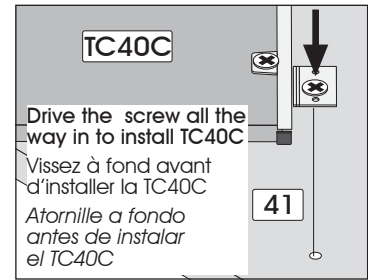
IMPORTANT / IMPORTANTE**3 possibilities / 3 possibilités / 3 posibilidades**

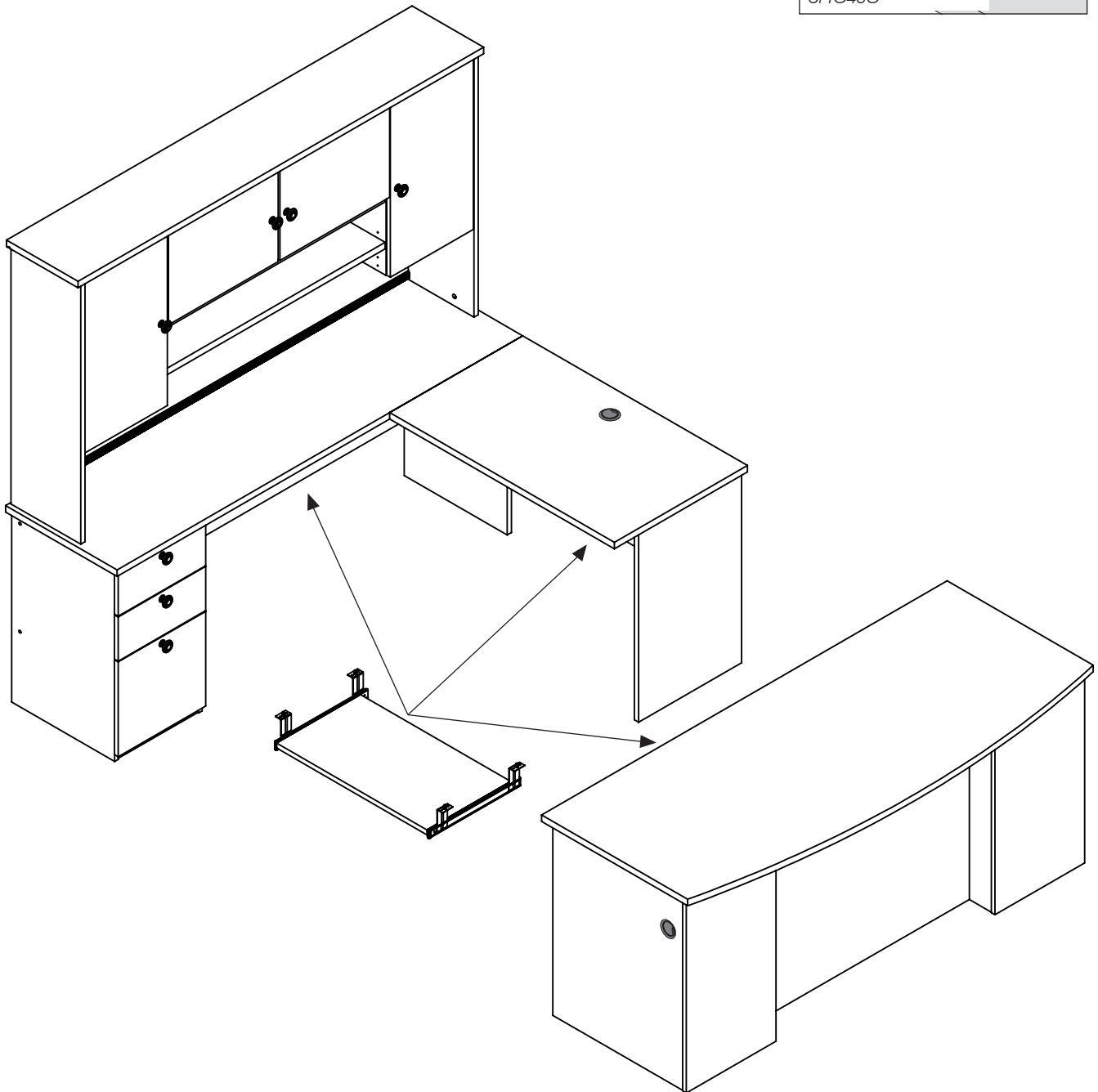
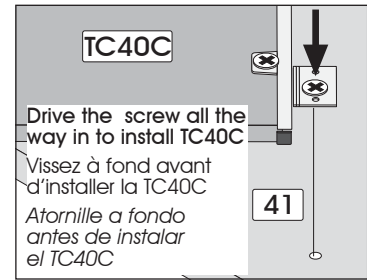
IMPORTANT / IMPORTANTE**3 possibilities / 3 possibilités / 3 posibilidades**



For future reference and to better serve you, please apply the self-adhesive sticker in an accessible space such as inside a drawer.

Pour mieux vous servir en cas de besoin, veuillez apposer l'autocollant dans un endroit facilement accessible tel que l'intérieur d'un tiroir.

Para futura referencia y mejor servicio por favor pegue la etiqueta en un lugar accesible, por ejemplo al interior de un cajón.

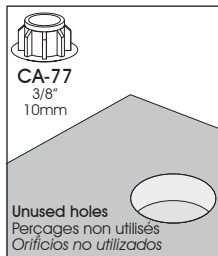
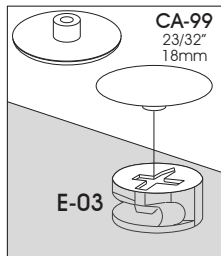

When you have completed the assembly of your new furniture, install plastic caps.

Lorsque vous avez complété l'assemblage de votre meuble, installez les capuchons de plastique.

Una vez que haya ensamblado el mueble, coloque los capuchones de plástico.

PRODUCT CARE / ENTRETIEN DU PRODUIT / MANTENIMIENTO DEL PRODUCTO

Avoid placing the furniture in the sunlight or near a source of heat. Use a soft dry cloth for dusting. To clean heavy dirt, use a cloth dipped in a solution of mild detergent and water. Avoid leaving wet objects on the surface or using commercial chemical cleaning products.

Évitez d'exposer le meuble au soleil ou près de toute source de chaleur. Pour le nettoyage, utilisez un chiffon doux et sec. Pour la grosse saleté, utilisez un chiffon humidifié avec un peu de détergent dilué dans l'eau. Évitez de laisser des objets mouillés sur la surface de votre meuble ou d'utiliser des nettoyants chimiques.

Evite exponer el mueble al sol o las fuentes de calor. Para limpiarlo, utilice un paño suave y seco. Para limpiar las manchas rebeldes, utilice un trapo húmedo con un poco de detergente diluido en agua. No deje objetos mojados encima del mueble ni utilice limpiadores que contengan productos químicos.

CONGRATULATIONS! YOU ARE NOW THE OWNER OF A QUALITY PRODUCT
 FÉLICITATIONS! VOUS AVEZ MAINTENANT EN VOTRE POSSESSION UN PRODUIT DE QUALITÉ
 FELICITACIONES! AHORA ES USTED DUEÑO DE UN PRODUCTO DE CALIDAD.

SERVICE/SERVICIO: 1-888 8BESTAR (1-888 823-7827)



For more information or to discover our new products

Pour toute information ou pour découvrir nos nouveaux produits
Para más información o descubrir nuestros nuevos productos

www.bestar.ca/site/en/register_your_product
www.bestar.ca/site/fr/enregistrement_de_produit

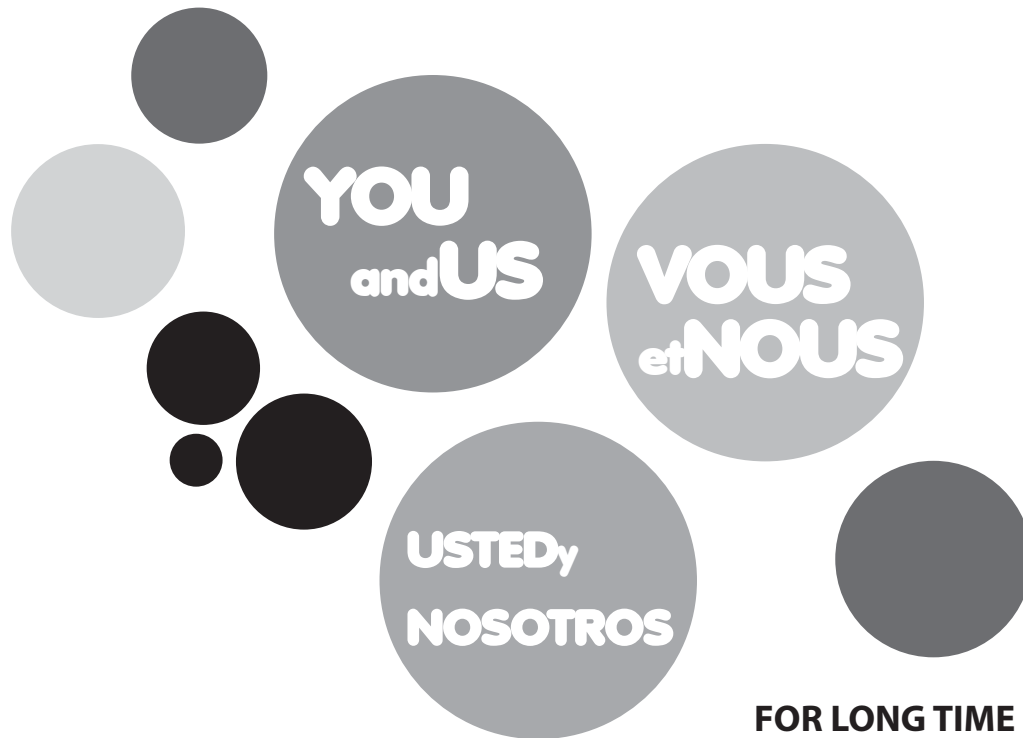

FOR LONG TIME
POUR LONGTEMPS
POR MUCHO TIEMPO

OUR FURNITURE IS GUARANTEED FOR 10 YEARS. NO MATTER THE PROBLEM, OUR CUSTOMER SERVICE IS THERE FOR YOU. COMPLETE WORDING OF THE GUARANTEE AVAILABLE AT WWW.BESTAR.CA/SITE/EN/WARRANTY/.



NOS MEUBLES SONT GARANTIS POUR 10 ANS. PEU IMPORTE LE PROBLÈME, N'HÉSITÉS PAS À COMMUNIQUER AVEC NOTRE SERVICE À LA CLIENTÈLE. LIBELLÉ COMPLET DE LA GARANTIE DISPONIBLE AU WWW.BESTAR.CA/SITE/FR/GARANTIE/.

NUESTROS MUEBLES TIENEN UNA GARANTÍA DE 10 AÑOS. NO IMPORTA EL PROBLEMA, COMUNIQUE CON NUESTRO SERVICIO A LA CLIENTELA. LA REDACCIÓN COMPLETA DE LA GARANTÍA ES DISPONIBLE A WWW.BESTAR.CA/ES/GARANTIA/.



BESTAR

The new logo shows an open and radiant person. It also evokes the past of BESTAR, the fact that we were the first manufacturer of ready-to-assemble furniture to design U-Shape furniture. Finally, if you take the logo in its simplest form, it shows that BESTAR is there for its employees, for its customers and for its consumers, "BESTAR is there for you (U)".

Le nouveau logo illustre un personnage ouvert et rayonnant. Il évoque également le passé de BESTAR qui fut le premier fabricant de meubles prêt-à-assembler à concevoir des bureaux en forme de «U». Finalement, si on prend le logo sous sa forme la plus simple, il rappelle que BESTAR est présent pour ses employés, ses clients et ses consommateurs.

El logotipo ilustra un personaje abierto y radiante. El evoca el pasado igualmente, porque Bestar es el primer fabricante de muebles listos a ensamblar que concibió los escritorios en forma de "U". Finalmente, si llevamos el logotipo a su forma más sencilla, nos recuerda que Bestar está presente para sus empleados, colegas y clientes. "BESTAR está aquí para USTED (U)".