

ASSEMBLY INSTRUCTIONS

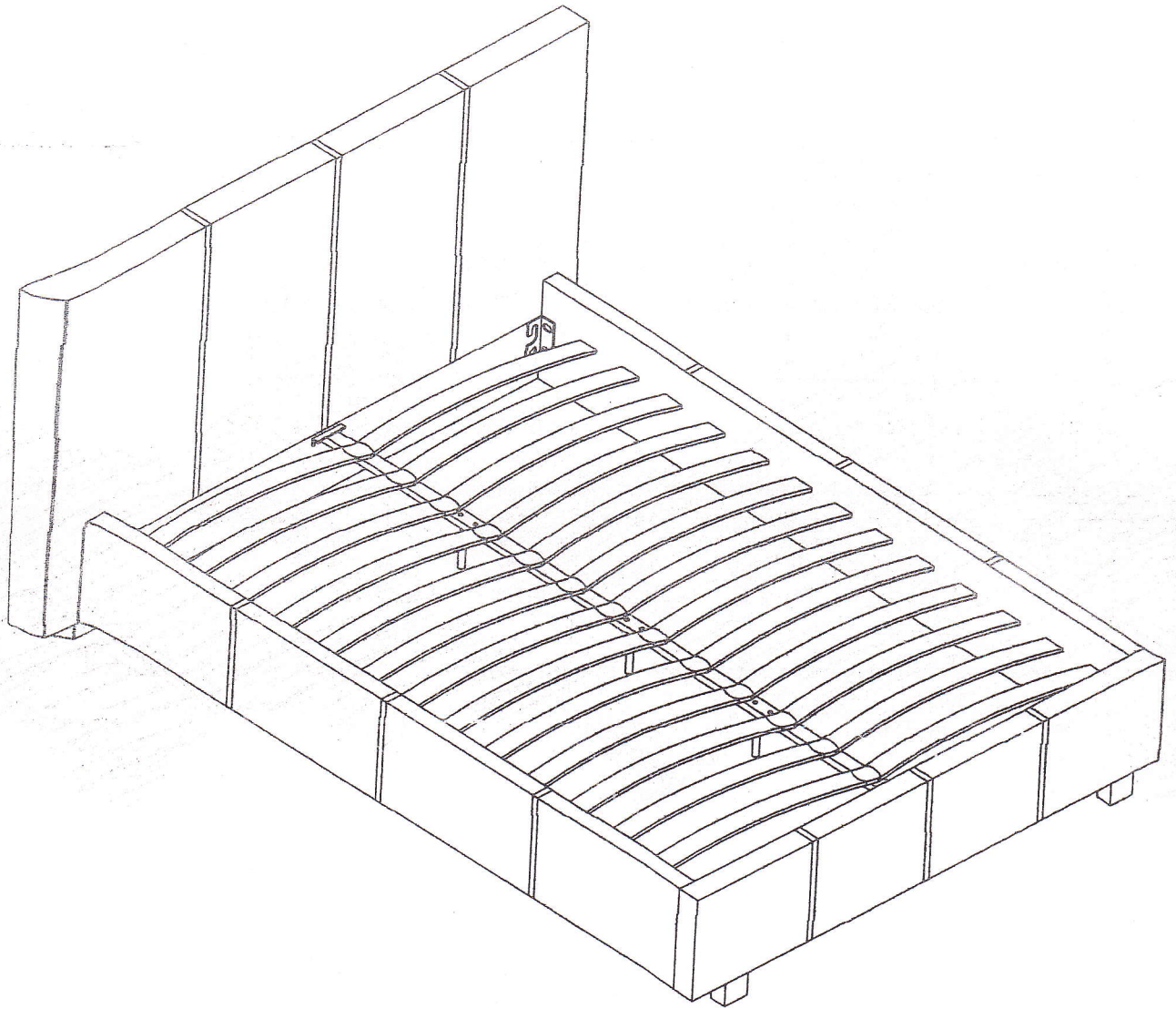

HELPFUL ADVICE PRIOR TO ASSEMBLING THE BED

- 1) Owing to the size and weight of the bed, we recommend that it is assembled by two adults, on a flat surface, in the room that it is intended for.
- 2) Please *do not* use any tools other than those provided or recommended in these instructions.
- 3) Please *do not* discard any packaging until you have checked that you have all the parts and fittings. Keep all fittings out of reach of children.
- 4) Assemble all parts loosely until advised to tighten. Depending on use, it may be necessary to tighten the fittings from time to time, so please save your allen key and spanner that has been provided.

A 16PCS-BOLT *1.2*20mm



B 13PCS-BOLT M6*15mm

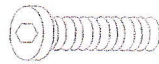

C 6PCS- T NUT M6*15mm

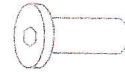

D 16PCS-FLAT WASHER



E 16PCS-SPRING WASHER



F 1PCS-ALLEN KEY 5MM



G 2PCS-ALLEN KEY 4MM



Hazard Warning!

Keep small components out of the reach of children

1 1PCS-Headboard

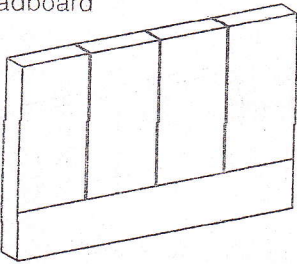

2 1PCS-Footboard

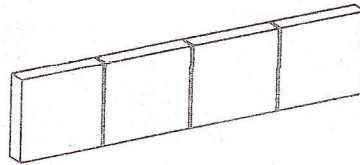

3 2PCS-Side Rail

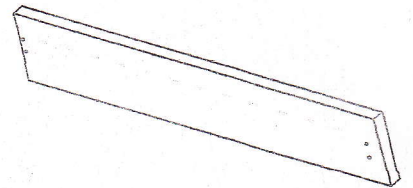

4 3PCS-"T"centre support leg

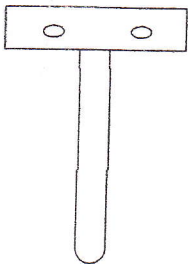

5 4PCS-Leg

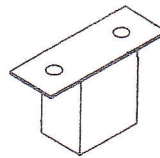

6 13/15PCS-Plastic slat cap

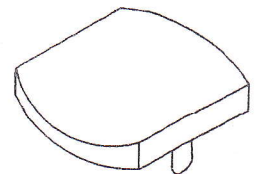

7 26/30PCS-Bent Slat

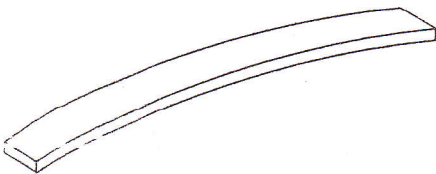

8 1PCS-Centre support rail

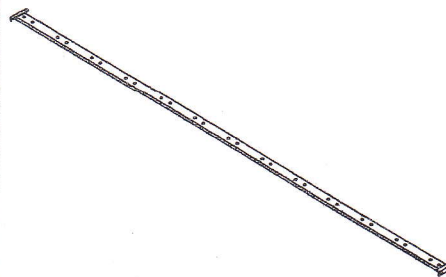

9 4PCS- Hook Bracket

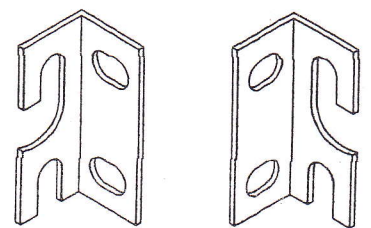

10 26/30PCS- and plastic cap

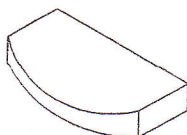

5

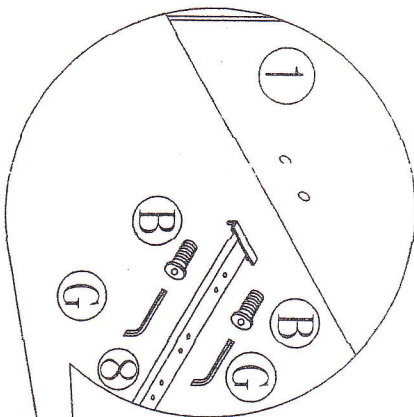

1

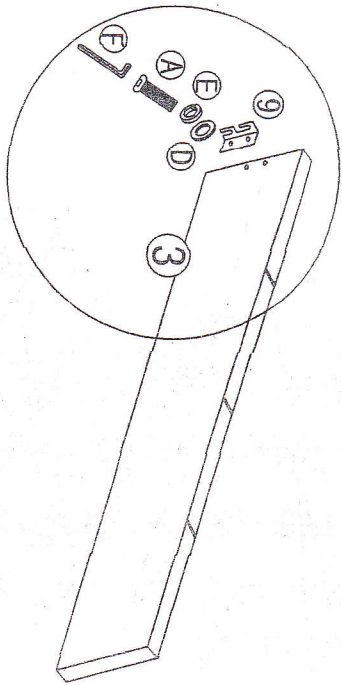

4

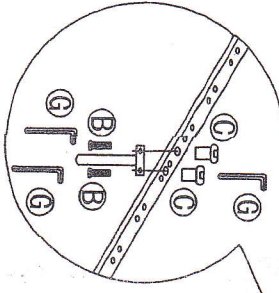

3

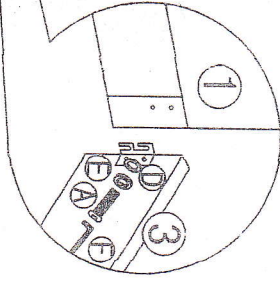

2

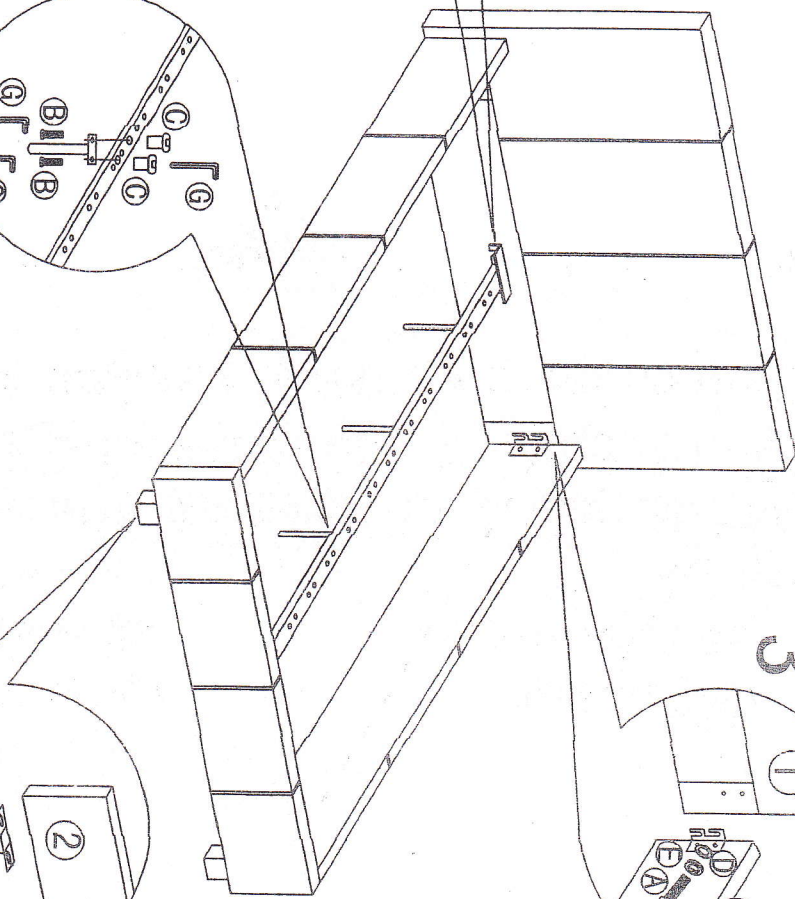
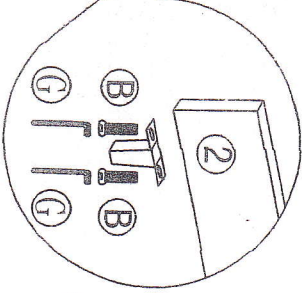

Step:

- 1) Assemble the hook bracket (9) to side rail (3) using bolts (A), Spring washer (E) and flat washer (D) as shown. Tighten the bolts using allen key (F).
- 2) Fix the legs (5) to headboard (1) and footboard (2) using bolts (B) as shown. Tighten the bolts using allen key (G).
- 3) Fix the side rails (3) to headboard (1) and footboard (2) using bolts (A), spring washer (E) and flat washer (D) as shown. Tighten the bolts using allen key (F).
- 4) Attach "T" centre support legs (4) to centre support rail (8) using bolts (B) and "T"nuts (C) as shown. Tighten the bolts using allen key (G).
- 5) Slot in centre support rails (8) to headboard (1) and footboard (2) using bolts (B) as shown. Tighten the bolts using allen key (G).
- 6) Attach the bent slats (7) with the end plastic slat cap (10) then follow by slotting onto side rail (3) pre-hole and attach the bent salts (7) with plastic slat cap (6) to centre support rail (8) as shown.

