

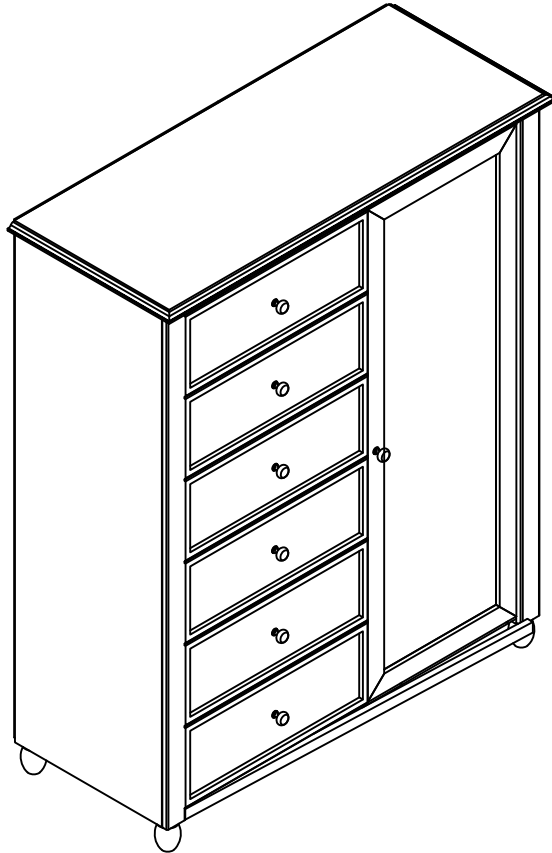

5905096



THIS INSTRUCTION BOOKLET CONTAINS **IMPORTANT** SAFETY INFORMATION. PLEASE READ AND KEEP FOR FUTURE REFERENCE.

ESTE FOLLETO DE INSTRUCCION CONTIENE INFORMACION **IMPORTANTE** DE SEGURIDAD. POR FAVOR LEA Y GUARDE PARA REFERENCIA FUTURA.



DO NOT RETURN PRODUCT TO THE STORE
Individual stores do not stock parts.

NO DEVUELVA ESTE PRODUCTO A LA TIENDA
Las tiendas no almacenan partes.

Lot Number / Número de Lote: _____

Date Of Purchase / Fecha de Compra: ___/___/___

If a part is missing or damaged, call our toll-free customer service line. We will gladly ship your replacement parts **FREE** of charge.

Si faltan partes o piezas, o éstas están dañadas, llame gratis al teléfono de servicio al cliente. Con gusto le enviaremos las partes sin cargo alguno.

Need Parts or Assistance?
Necesitas partes o asistencia?

1-800-489-3351

or access our website
o visite nuestra página de internet

www.altrafurniture.com

For prompt, reliable service please have your assembly manual ready.
Para obtener servicio rapido y confiable, por favor tenga esta manual a la mano.

Recommended # of people needed for assembly: 2

El número recomendado de personas necesarias para el montaje: 2

B34590509600

Thank you for purchasing from Altra Furniture.
Visit www.altrafurniture.com to view the limited
warranty valid in the U.S. and Canada.

ALTRA FURNITURE CUSTOMER SERVICE

Gracias por haber comprado de Altra Furniture.
Visitar www.altrafurniture.com para mirar la garantía
limitada valida solamente en U.S.A y Canada.

SERVICIO A LA CLIENTE DE ALTRA FURNITURE

Before starting - Antes de empezar.

- Read each step carefully before starting. It is very important that each step of instruction is performed in the correct order. If these steps are not followed in sequence, assembly difficulties will occur.
Leer con cuidado cada paso antes de empezar. Es muy importante de ejecutar cada paso en el orden correcto. Si los pasos no estan ejecutados en secuencia, ocurrirá dificultades en el montaje.
- Make sure all parts are included. Most board parts are labeled or stamped on the raw edge.
Asegurar que todas las piezas son incluidas. La mayoría de las tablas tienen las etiquetas o los sellos en el lado sin acabado.
- Work in spacious area, preferably on a carpet, near the place the unit will be used.
Trabajar en una área espaciosa, preferible sobre alfombra, cercas del lugar donde se va a usar el mueble.
- Have the following tools close at hand.
Tener las herramientas siguientes cerca de la mano.
- Do not use power tools to assemble your furniture. Power tools may strip or damage the parts.
No use herramienta electrica para montar su unidad. Las herramientas electricas pueden dañar las piezas.

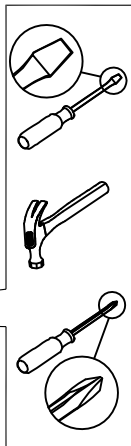

Call us at: 1-800-489-3351
Llamar a: (In U.S.A. only)
(Solo en U.S.A)

Monday - Friday 7:00 am - 8:00 pm Central Time	Saturday 9:00 am - 5:00 pm Central Time
--	---



Fax: 1-636-745-1005

Lunes - Viernes 7:00h - 20:00h Tiempo Central	Sabado 9:00h - 17:00h Tiempo Central
---	--



Visit our Website:
Visitar nuestro website: www.altrafurniture.com



Write to: ALTRA FURNITURE
Escribir a: 410 East 1st Street South Wright City, MO 63390 USA
Attn: Service Dept.

HELPFUL HINTS

- Visit our website for assembly video clips.
- Identify, sort and count the parts before attempting assembly.
- Call our toll free number if you need assistance identifying parts.
- Compression dowels are tapped in with a hammer.
- Slides have lips only on the right side.
- Cam locks that are properly fastened on a horizontal board will face toward the center of the unit, on a vertical board the point on the lock will face the bottom.
- Back panels provide stability and support. Use all the nails provided.
- When tapping nails into a board, be sure there are equal margins on all sides to square the unit.
- Units without the back panel installed may collapse.
- Clean the product with your favorite furniture polish and a soft cloth. **DO NOT USE** harsh chemicals or abrasive cleaners.
- Move your new furniture carefully, with two people lift and carry the unit to it's new location.
- Never push, drag or scoot your furniture (especially on carpet).
- Your furniture can be disassembled and reassembled to move.
- Additional parts are available for a nominal fee.

NOTES UTILES

- Visitar nuestro website para mirar los videos cortos del montaje.
- Identificar, clasificar y contar las piezas antes de intentar el montaje.
- Llamar gratis a nuestro número de servicio si necesite ayuda con identificar las piezas.
- Las clavijas de compresión se taladran con un martillo.
- Las correderas sólo tienen las proyecciones en el lado derecho.
- Las cerraduras de leva que se atan propiamente en una tabla horizontal se puntan al centro de la unidad, y las en una tabla vertical se puntan al fondo.
- Los paneles traseros se mantienen la estabilidad. Usar todos los tornillos proporcionados.
- A taladrar los tornillos en una tabla, asegurarse que hay márgenes iguales en todos los lados para cuadrar la unidad.
- Las unidades sin panel trasero pueden derrumbarse.
- Limpiar la unidad con su pulimento favorito de mueble y una tela suave. **NO UTILIZAR** productos con químicos duros o abrasivos.
- Mover su mueble nuevo cuidadosamente, con dos personas levantar la unidad a su nuevo lugar.
- Nunca empujar o arrastrar su mueble (especialmente en alfombra).
- Poderse desmontar y volver a montar su mueble de para mover.
- Piezas adicionales están disponibles para una cuota nominal.

PARTS -PIEZAS

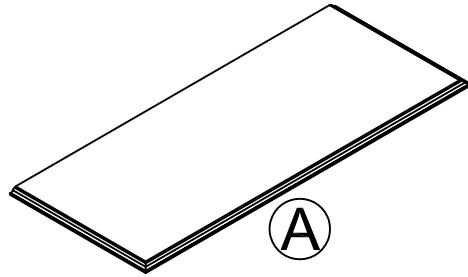

TOP
Panel superior
T5905096010

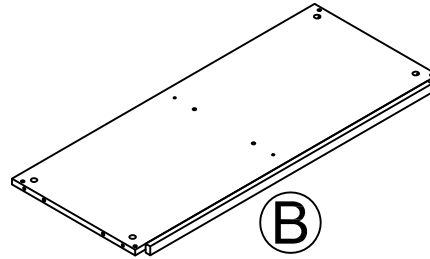

BOTTOM
Base
T5905096020

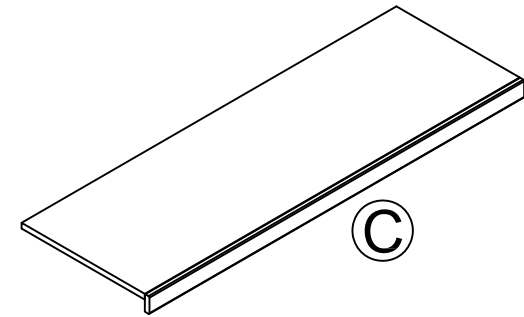

LEFT SIDE PANEL
Panel lateral izquierdo
T5905096030

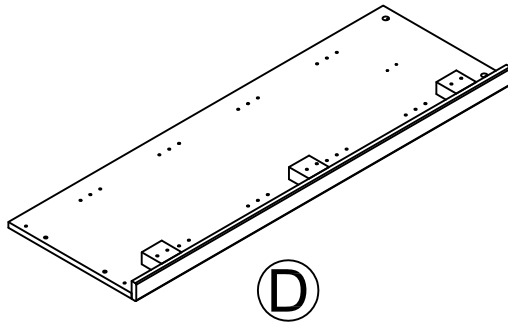

RIGHT SIDE PANEL
Panel lateral derecho
T5905096040

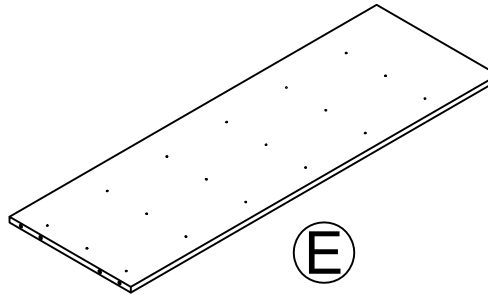

PARTITION
Partición
T5905096050

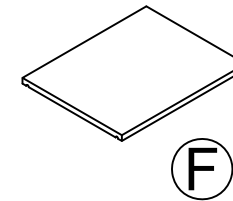

ADJUSTABLE SHELF
Repisa ajustable
T5905096060
QTY:4

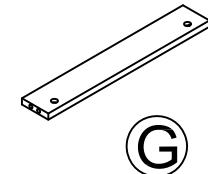

MIDDLE RAIL
Riel medio
T5905096070
QTY:2

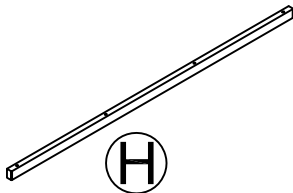

FRONT UP RAIL
Frente encima del carril
T5905096080

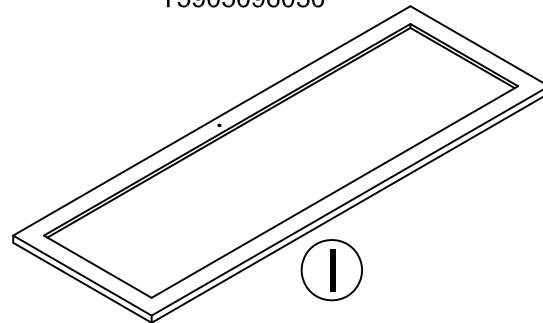

DOOR
Puerta
T5905096090

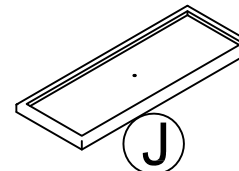

DRAWER FRONT
Frente del cajón
T5905096100
QTY:6

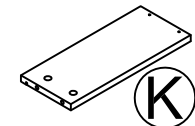

LEFT DRAWER SIDE
Lado izquierdo del cajón
T5905096110
QTY:6

PARTS -PIEZAS

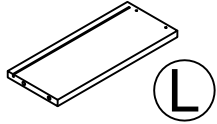

RIGHT DRAWER SIDE
Lado derecho del cajón
T5905096120
QTY:6

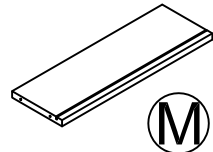

DRAWER BACK
Parte posterior del cajón
T5905096130
QTY:6

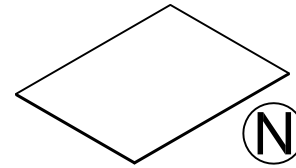

DRAWER BOTTOM
Londo del cajón
T5905096140
QTY:6

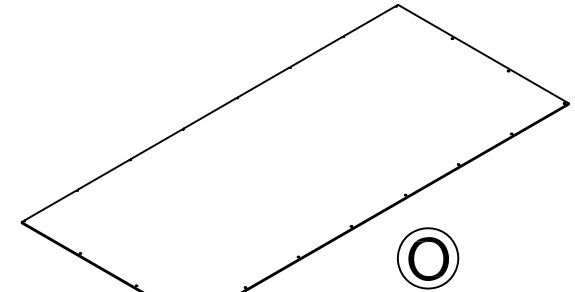

LEFT BACK PANEL
Panel trasero izquierdo
T5905096150

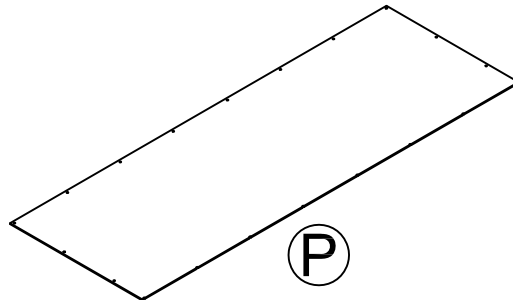

RIGHT BACK PANEL
Panel trasero derecho
T5905096160



FOOT
Pie
T5905096170
QTY:4



ADJUSTABLE LEG
Pierna ajustable
T5905096180

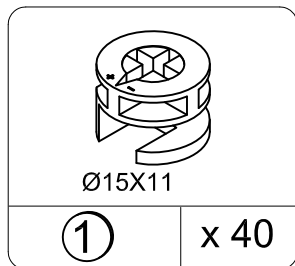

CAM LOCK
Tornillo de cerradura
THX5103

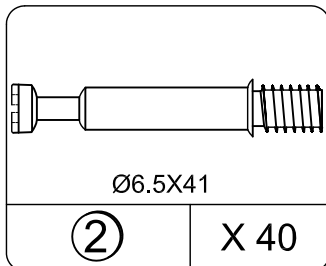

CAM BOLT
Tornillo de rosca
THX5203

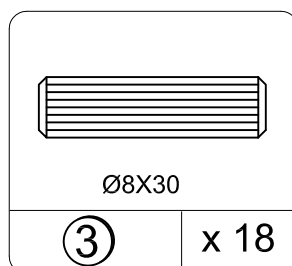

WOOD DOWEL
Clavija de madera
THX8201

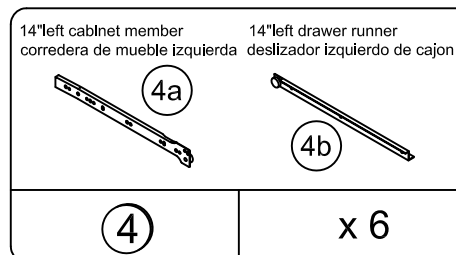

LEFT SLIDE
Corredera-L
THX2203

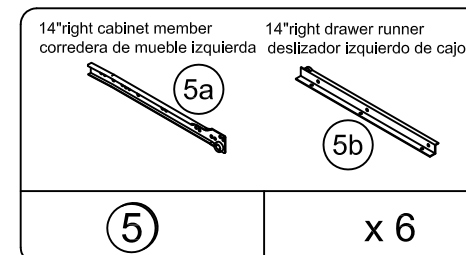

RIGHT SLIDE
Corredera-R
THX2204

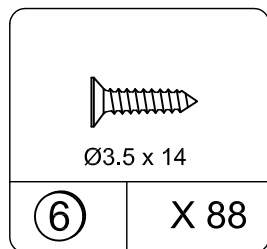

SCREW
Tornillo
THX4321

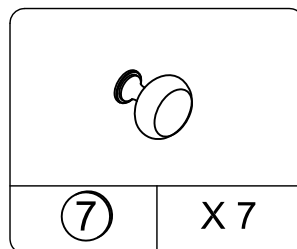

KNOB
Perilla
THX1321

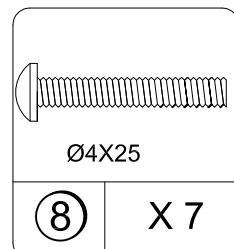

BOLT
Tornillo
THX4125

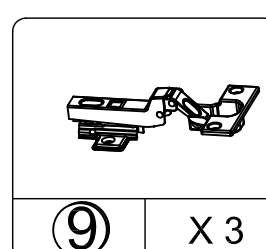

HINGE
Bisagra
THX3226

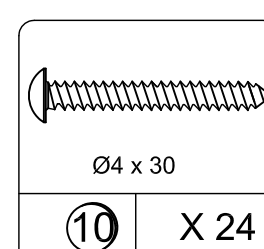

SCREW
Tornillo
THX4314

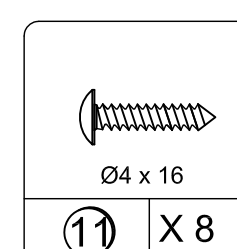

SCREW
Tornillo
THX4332

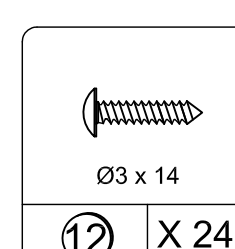

SCREW
Tornillo
THX4331

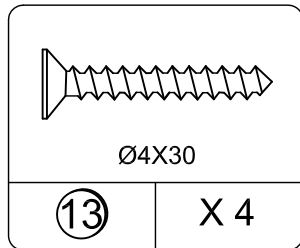

SCREW
Tornillo
THX4203

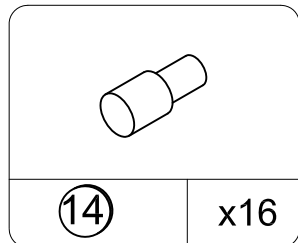

SHELF SUPPORT
Support de tablette
THX6105

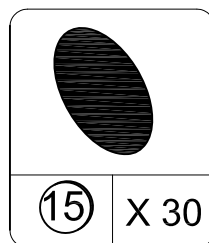

COVER
Cubre
THX5301

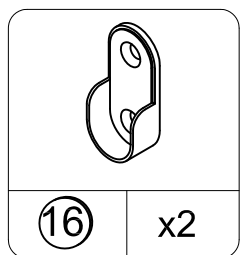

ROD HOLDER
Support de tringle
THX9553

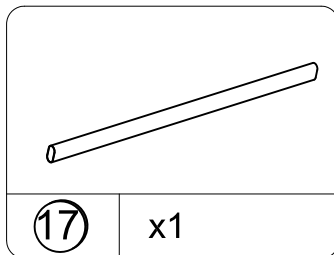

HANGING ROD
Tringle
THX9554

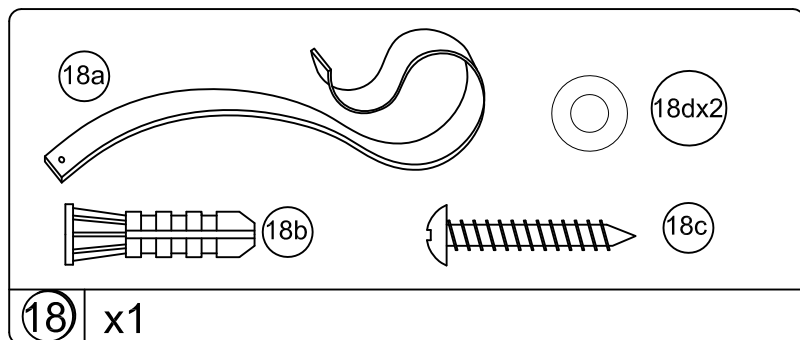

SAFETY STRAP KIT
Kit de la correa de seguridad
THX4402

This illustration shows how the CAM fastening system works.

Esta ilustración muestra como funciona el sistema de fijación de leva.

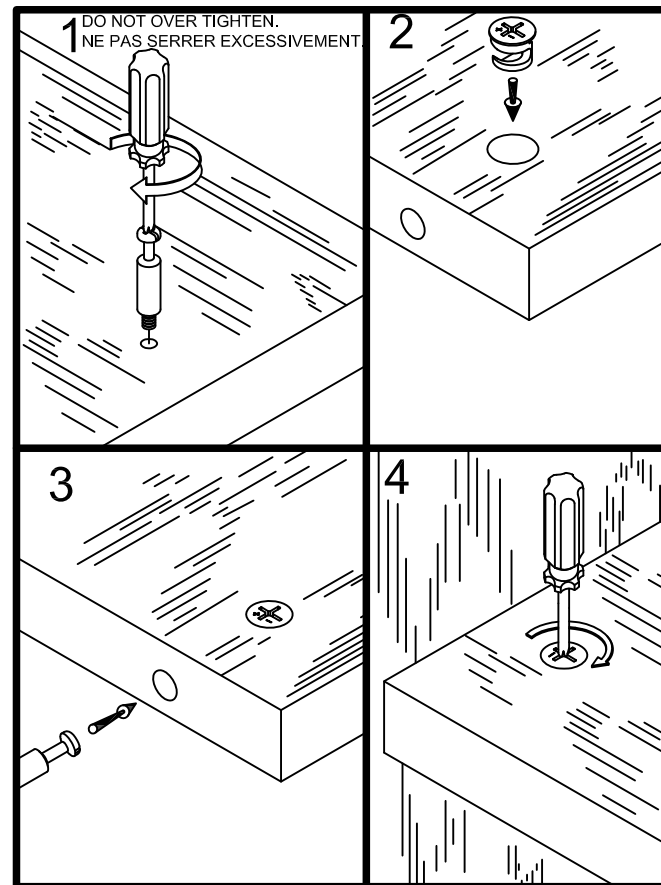

To view a video on how the CAM fastening system works, download a free QR-reader on your smartphone, then scan the code.

Para ver un video de como funciona el sistema de sujeción CAM, descargue una aplicación gratis que podra ver en su teléfono movil, entonces escnee el código.

1

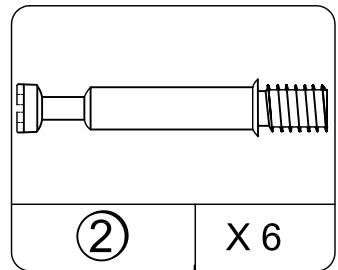
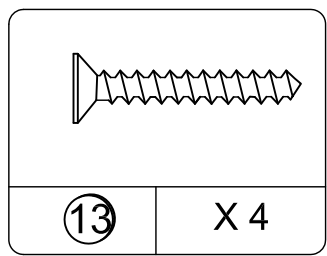
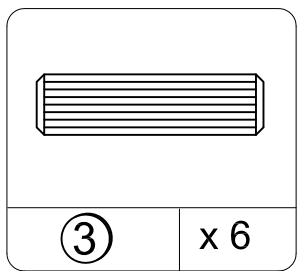
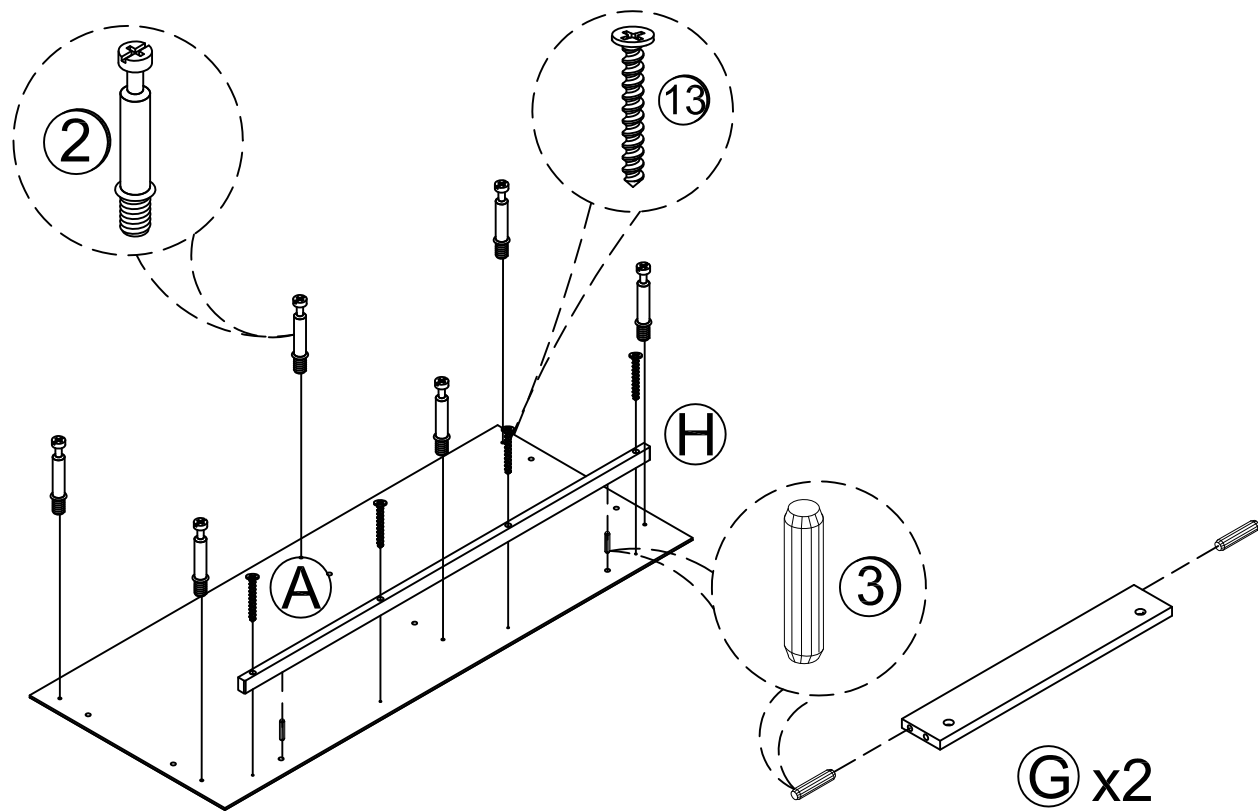

2

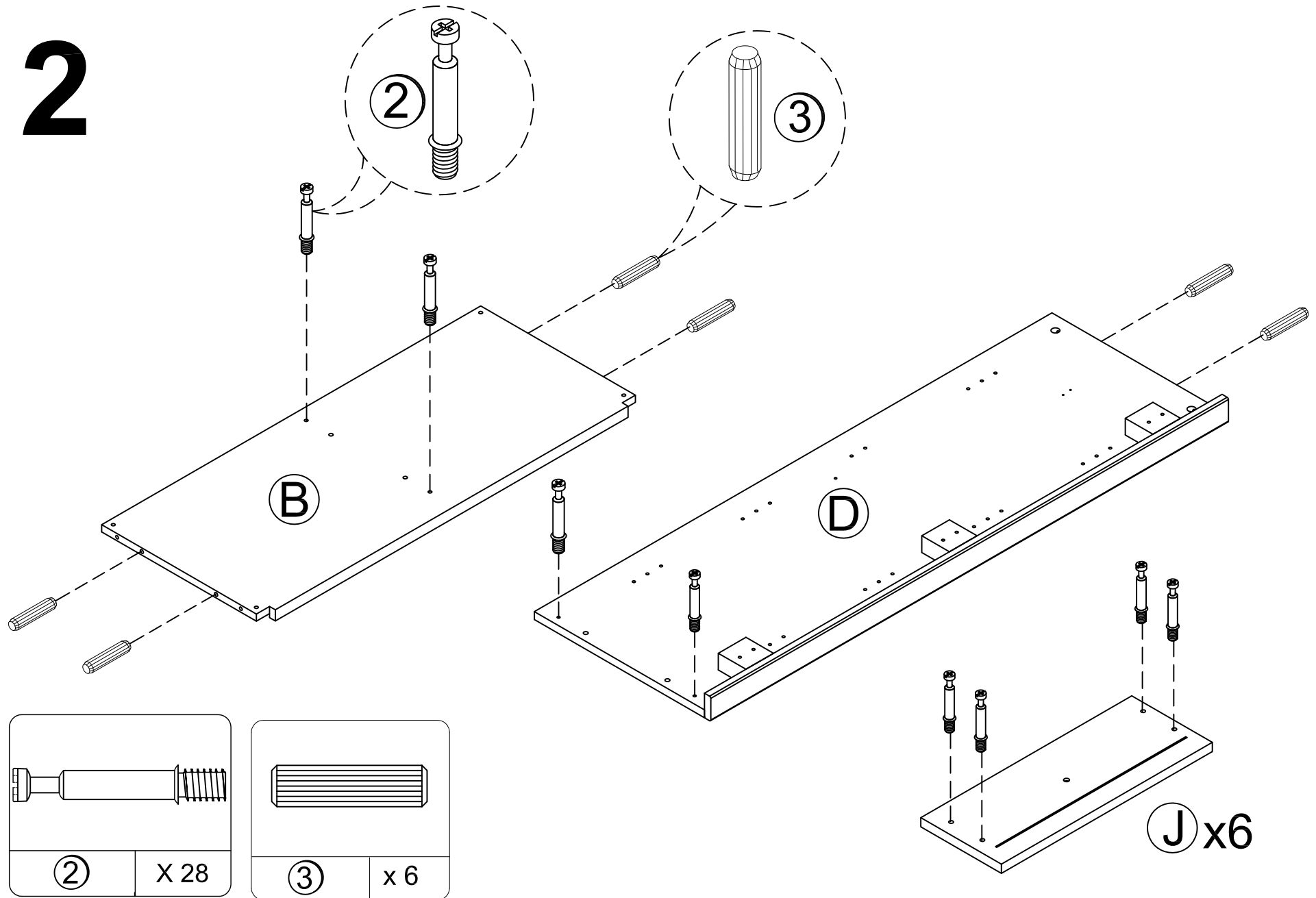

3

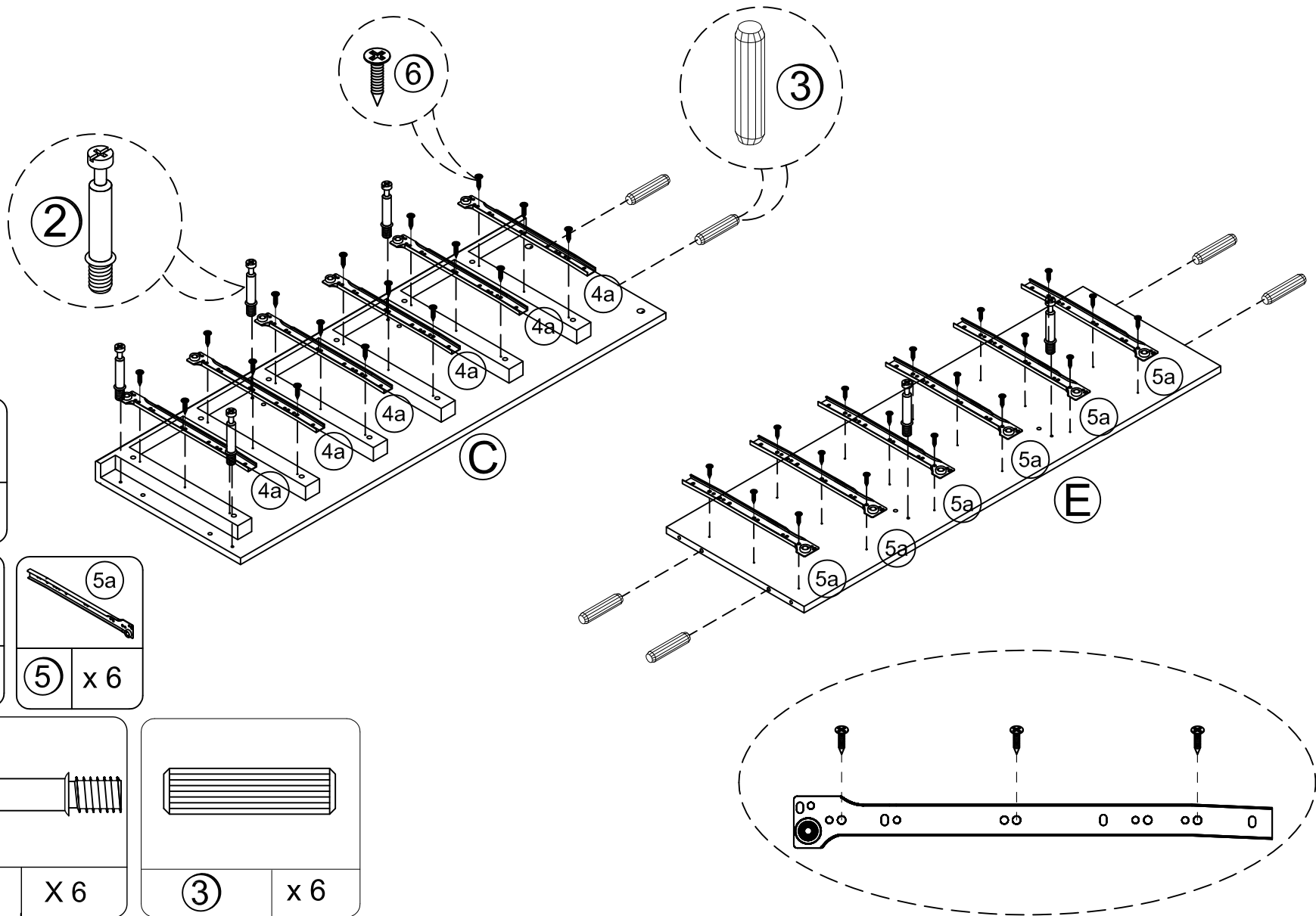

4

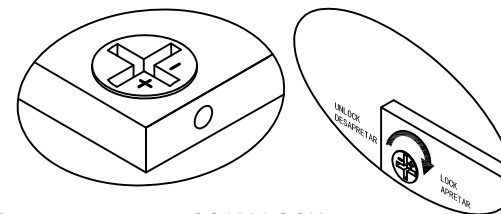
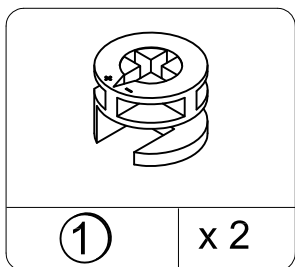
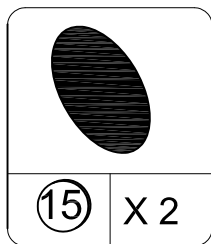
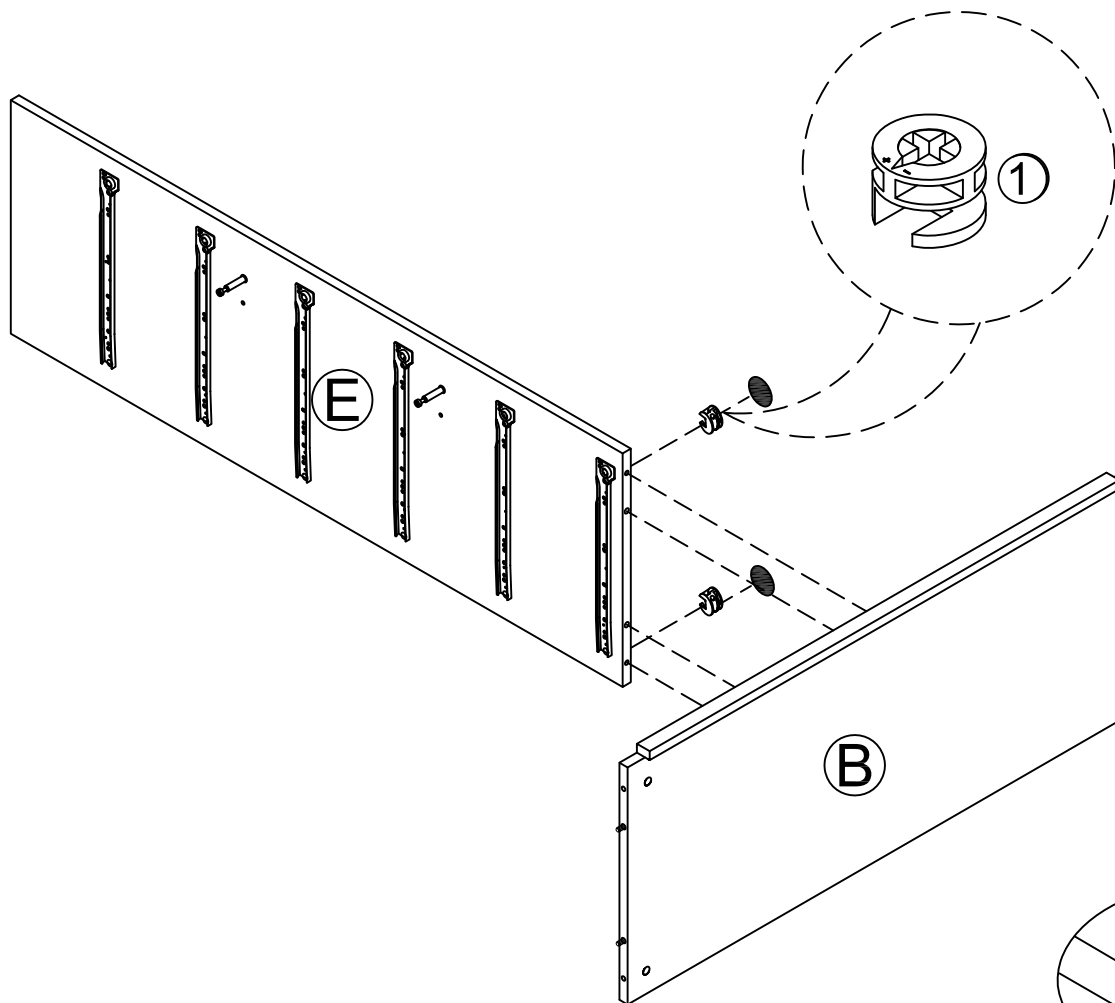

Proper orientation of CAM LOCK
Bonne orientation de la SERRURE DE CAME

5

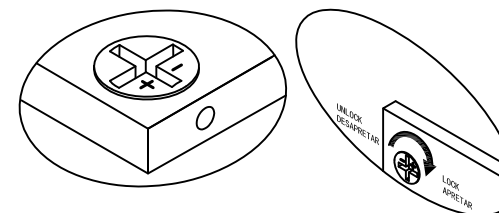
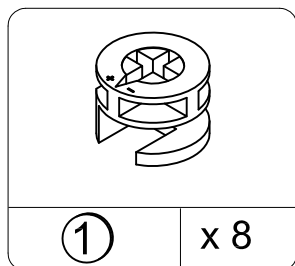
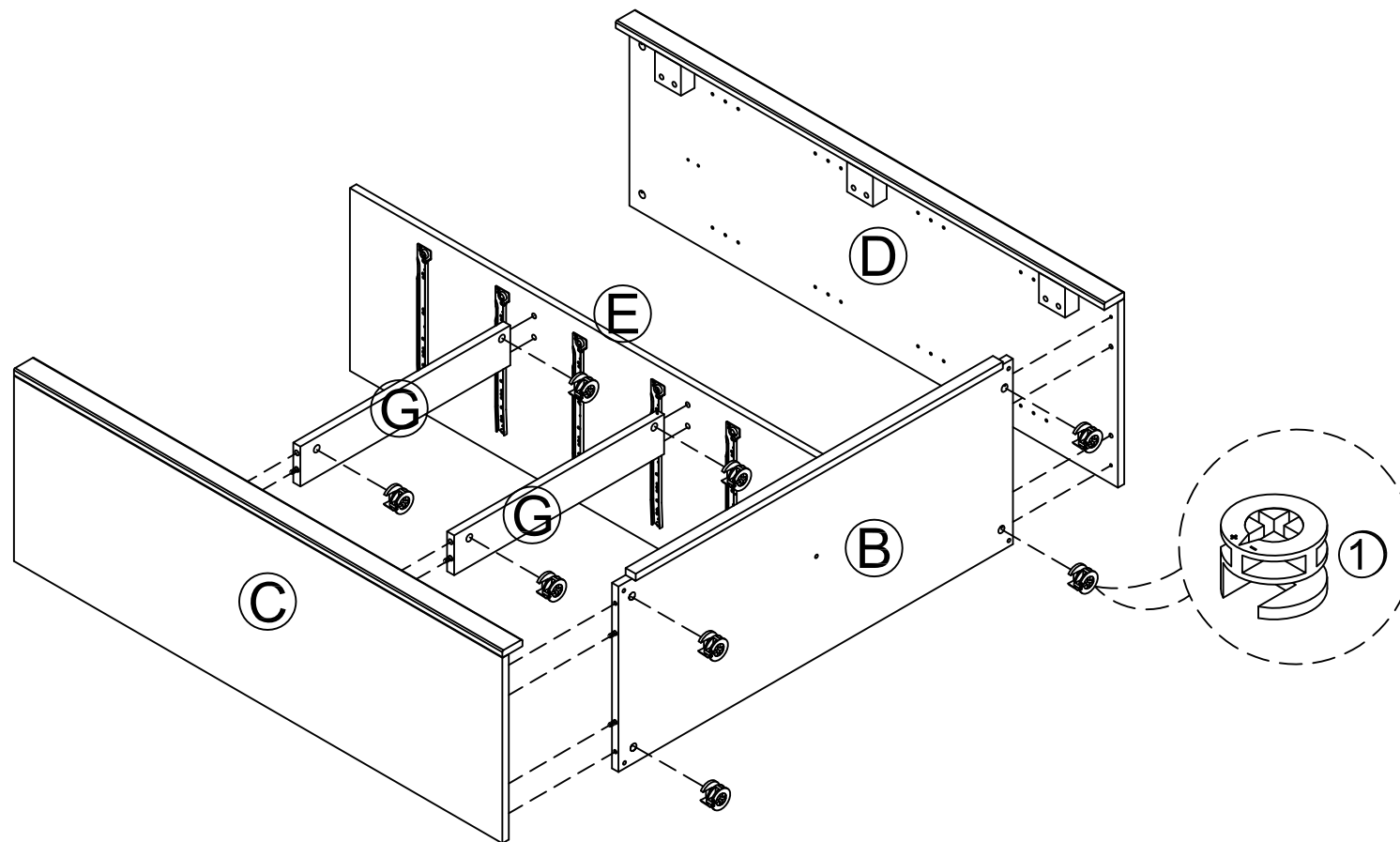

Proper orientation of CAM LOCK
Bonne orientation de la SERRURE DE CAME

6

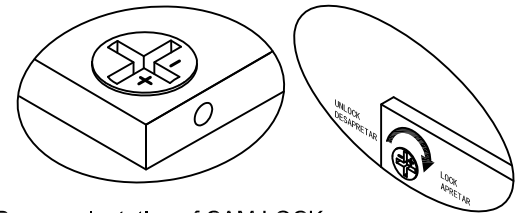
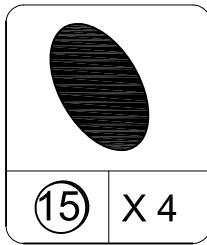
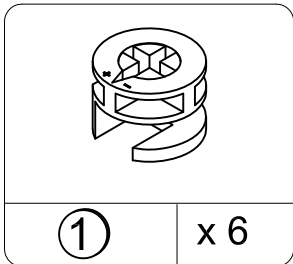
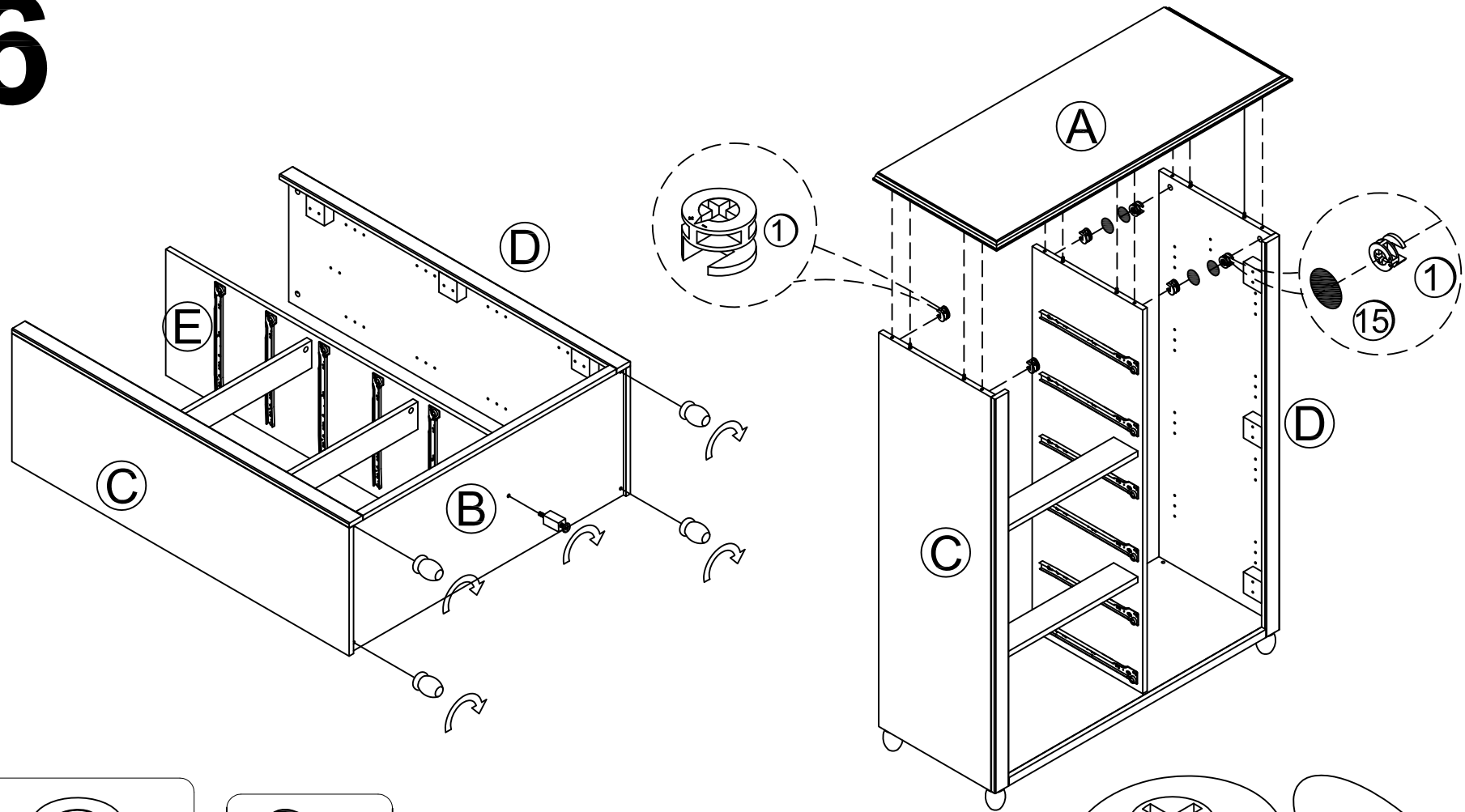

Proper orientation of CAM LOCK
Bonne orientation de la SERRURE DE CAME

7

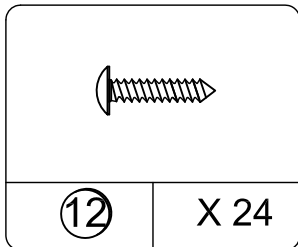
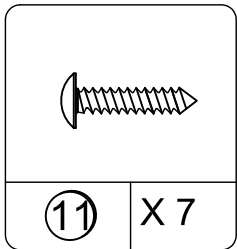
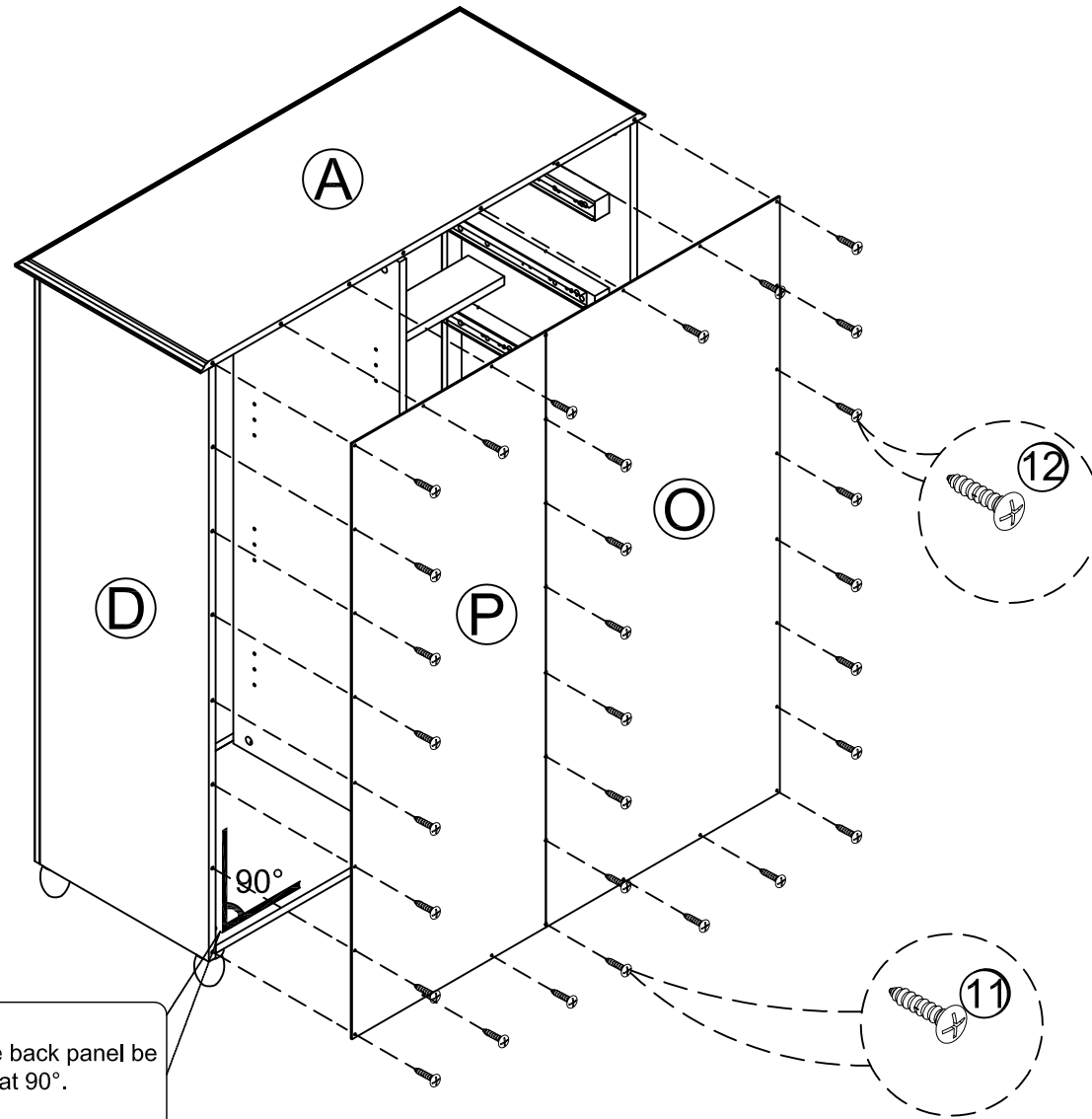

Before attaching the back panel be sure that the unit is at 90°.

8

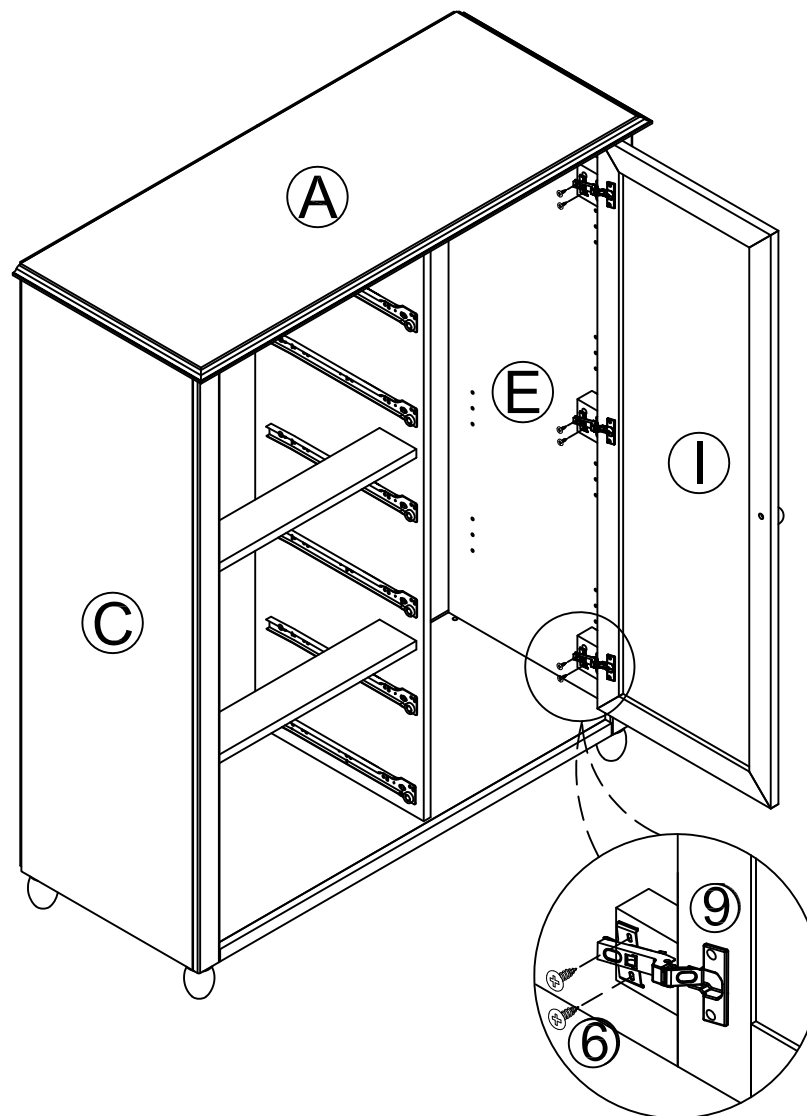
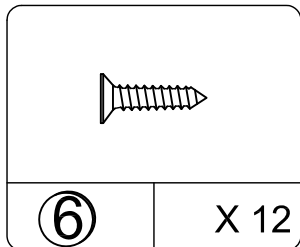
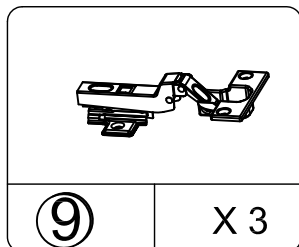
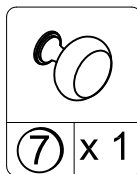
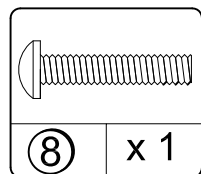
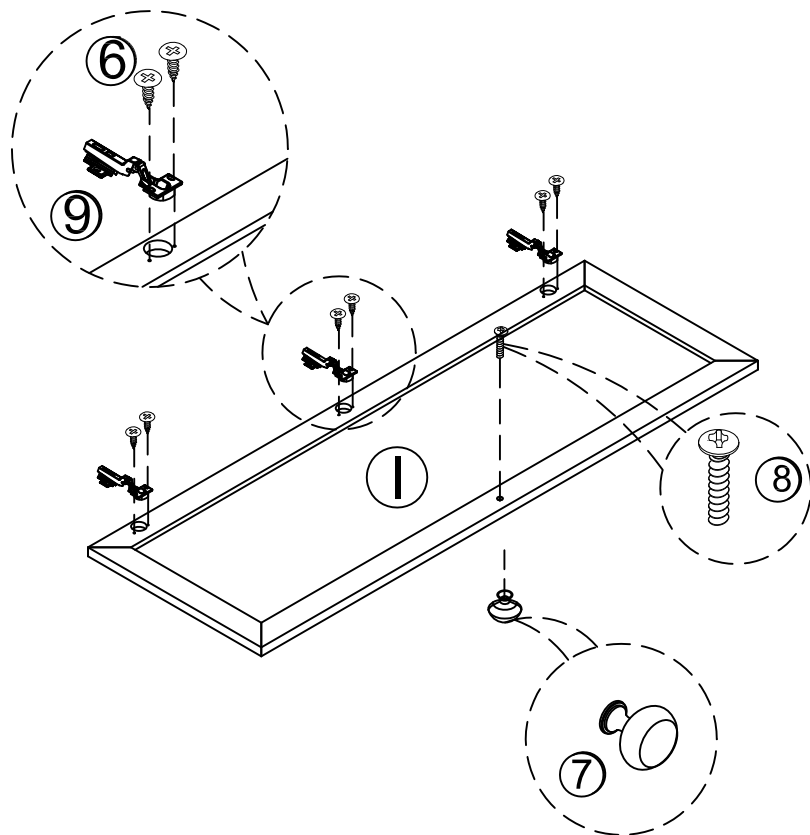

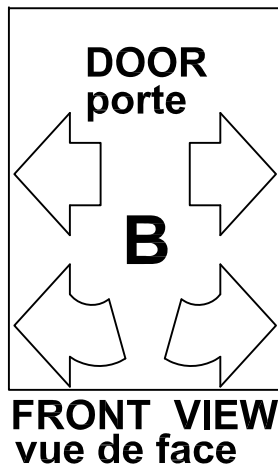
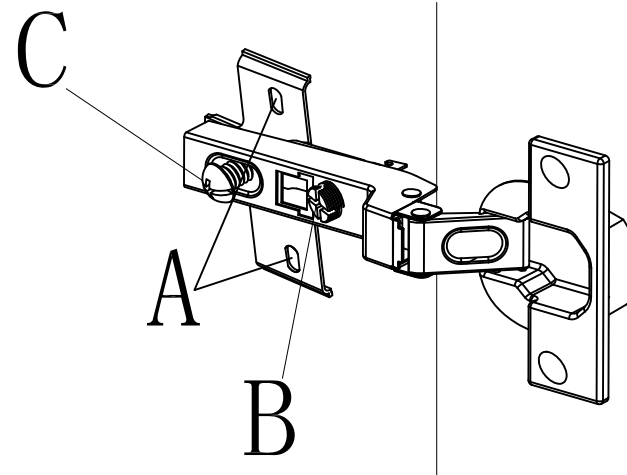
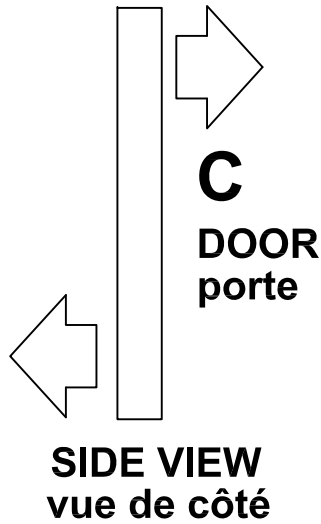
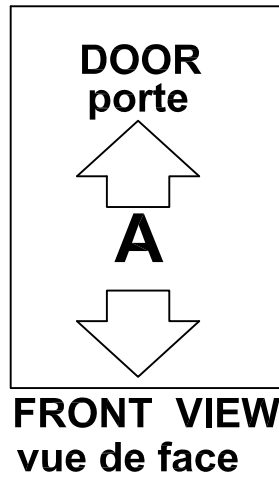

To adjust doors:"A"
Loosen "A" screws.
Adjust door.
Tighten "A" screws.

Pour ajuster les portes: "A"
Desserrez les vis "A".
Ajustez la porte.
Serrez les vis "A".

To adjust doors:"B"
Loosen "C" screw.
Turn "B" to move door.
Tighten "C" screws.

Pour ajuster les portes: "B"
Desserrez la vis "C".
Tournez la vis "B" pour déplacer
la porte
Serrez la vis "C".

To adjust doors:"C"
Loosen "C" screws.
Adjust door.
Tighten "C" screws.

Pour ajuster les portes: "C"
Desserrez la vis "C".
Ajustez la porte.
Serrez la vis "C".

9x6

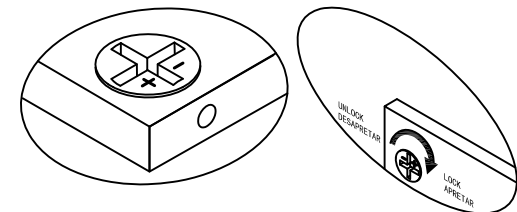
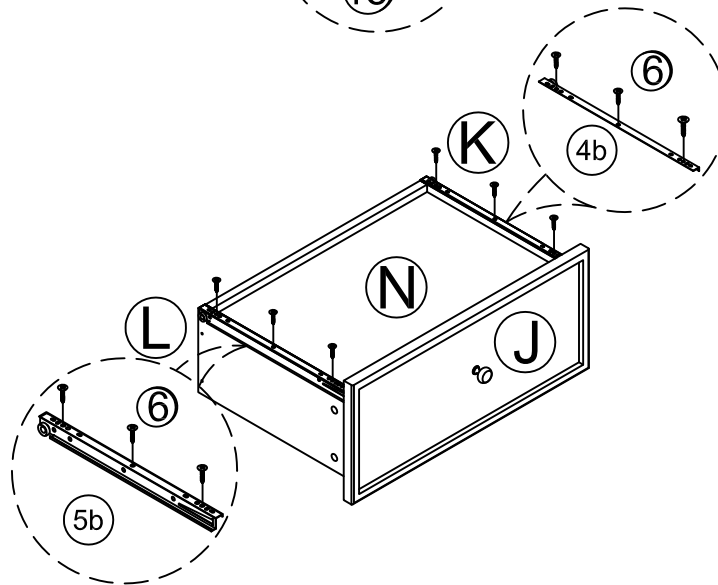
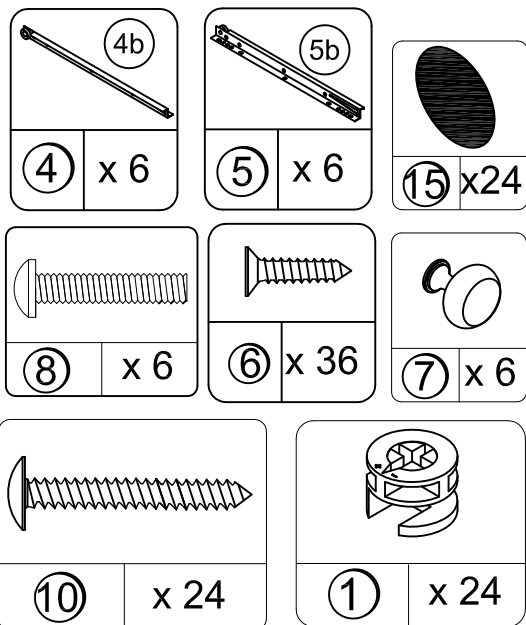
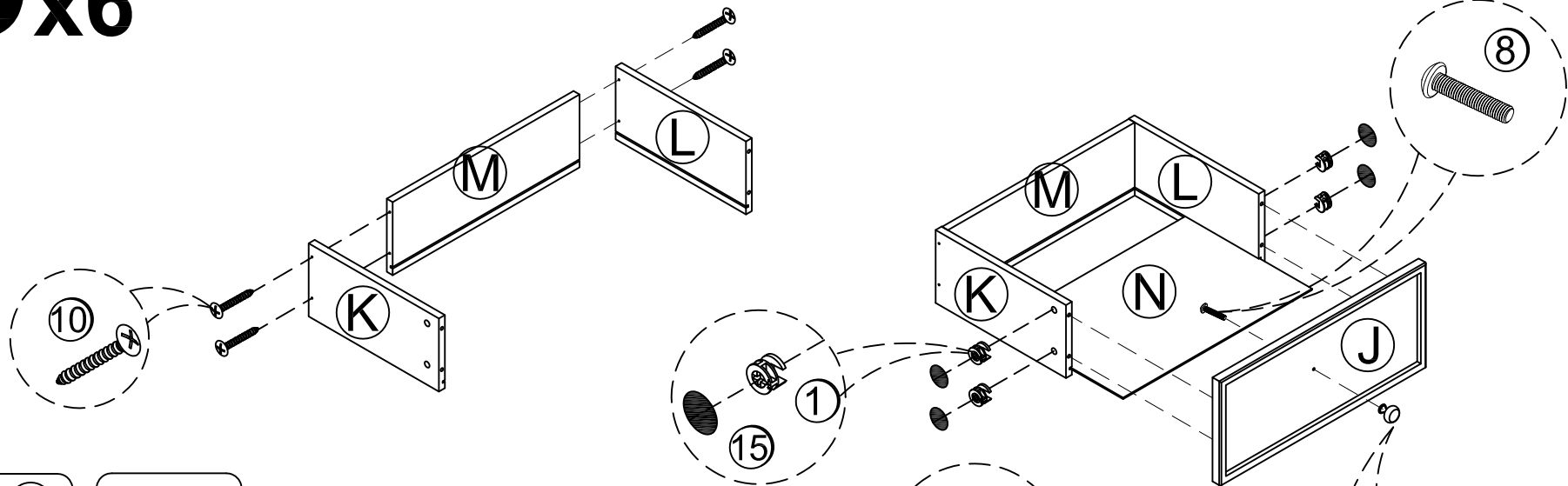

Proper orientation of CAM LOCK
Bonne orientation de la SERRURE DE CAME

10

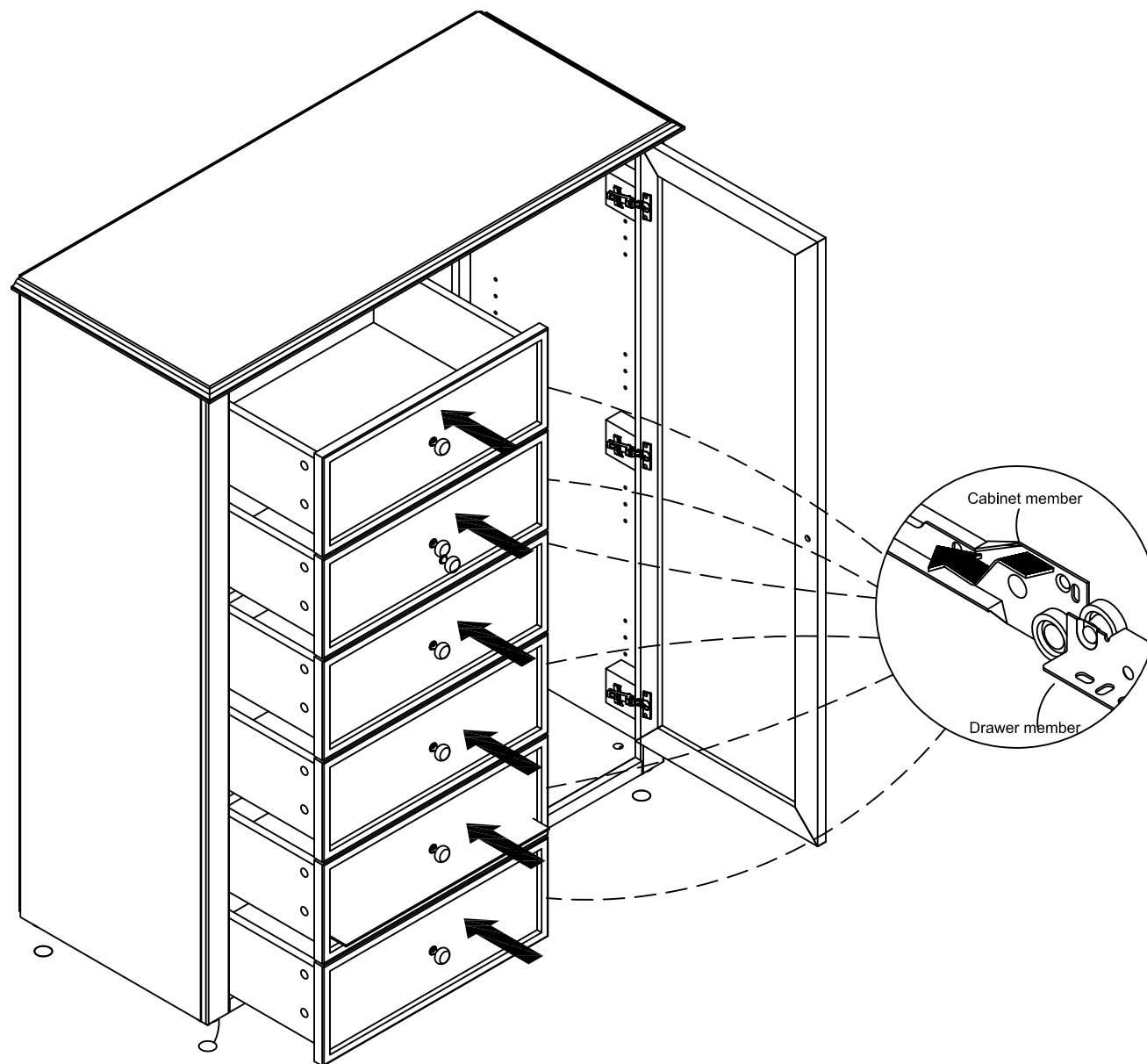

11

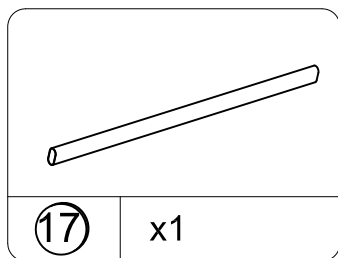
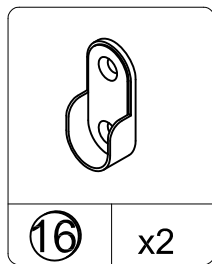
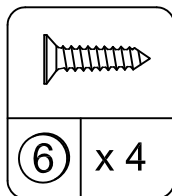
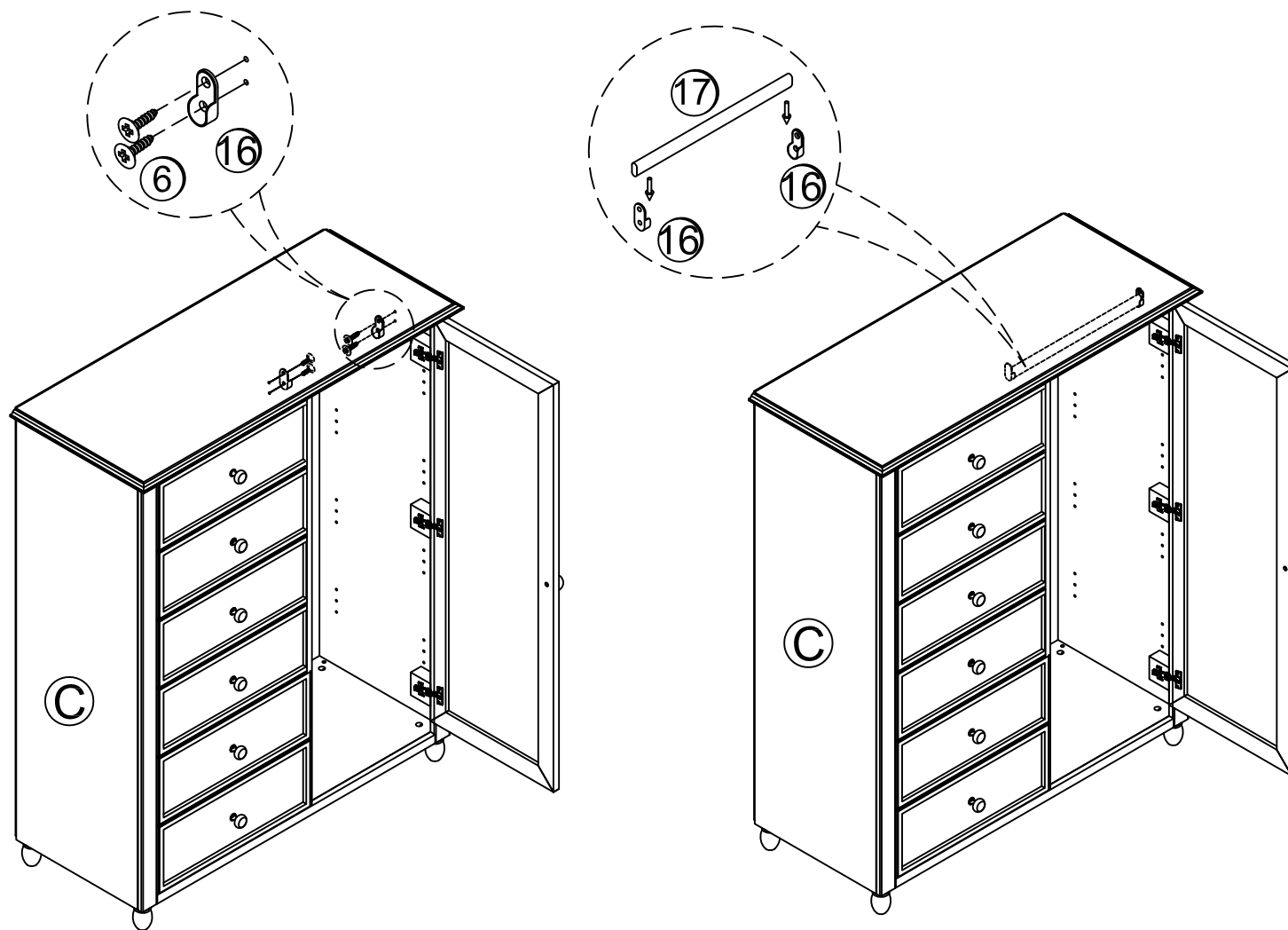

12

Reminder: Right Side Cabinet can accommodate the installation of adjustable shelves or hanging clothes rod. If adjustable shelves option is chosen, please make sure that the hanging clothes rod is disassembled from the unit, otherwise the upper most adjustable shelf will hit the hanging clothes rod and could cause damage. If the hanging clothes rod and adjustable shelves should be used together, the upper most shelf will not be able to fit. So, there will be one extra shelf not used in this situation.

Aviso: El gabinete lateral derecho permite la instalación de estantes ajustables o de barras colgadoras. Si elige la opción de estantes ajustables, por favor asegúrese de que las barras colgadoras estén desmontadas de la unidad, de lo contrario el estante superior podría golpear una de las barras colgadoras y causar daños. Si la barra colgadora es usada al mismo tiempo que los estantes, el estante superior no puede ser usado. Así que deberá prescindir de su uso y almacenarlo como recambio.

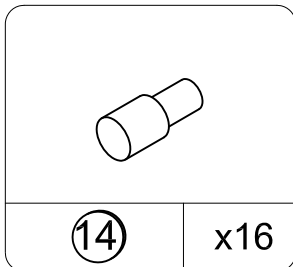
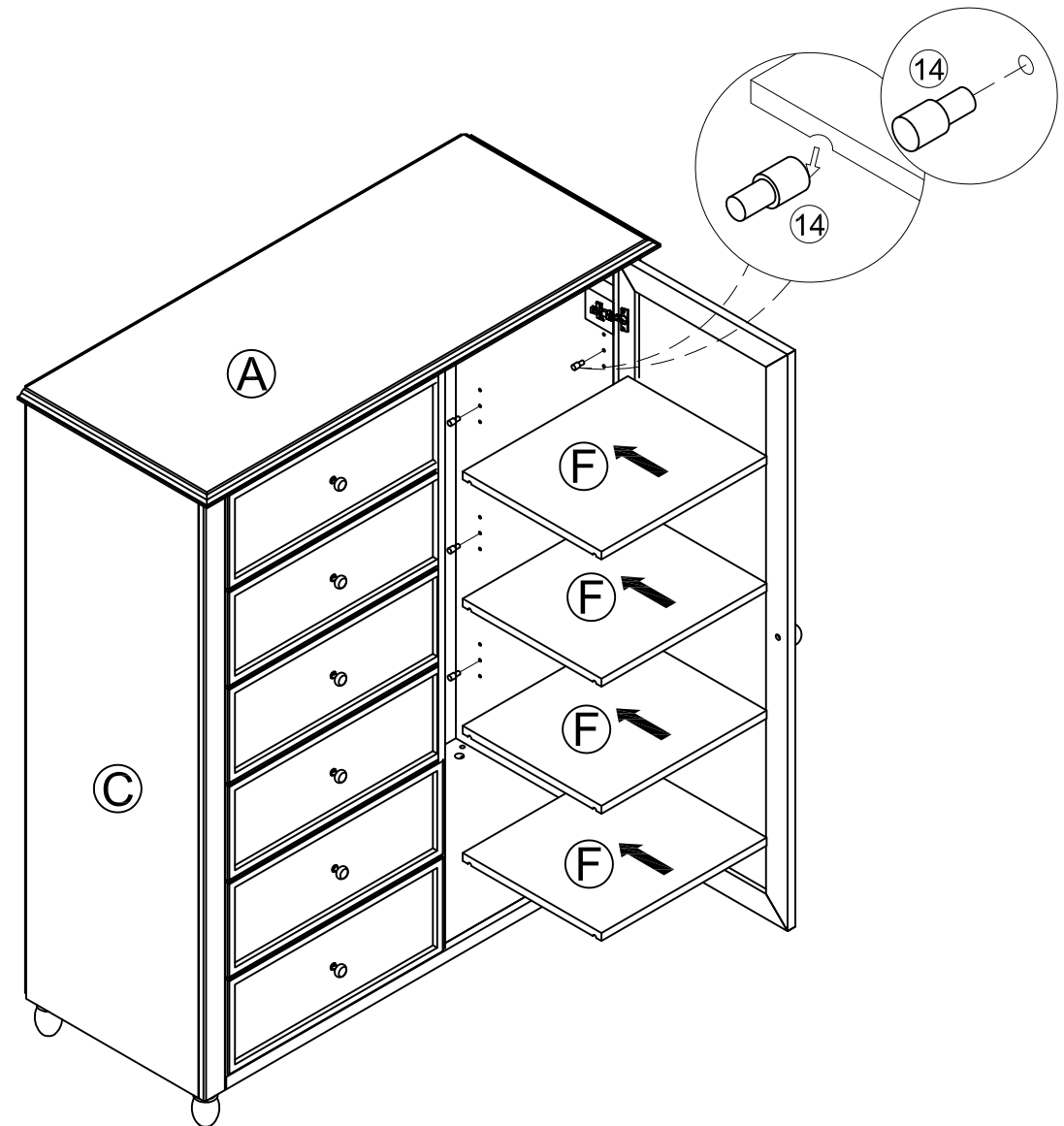

13

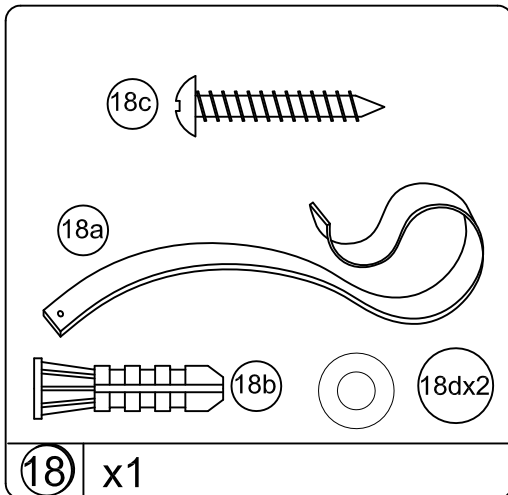
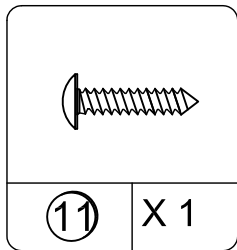
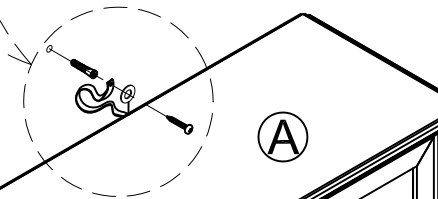
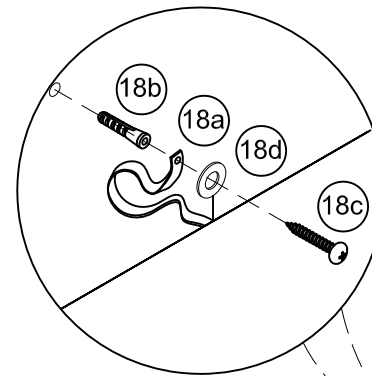
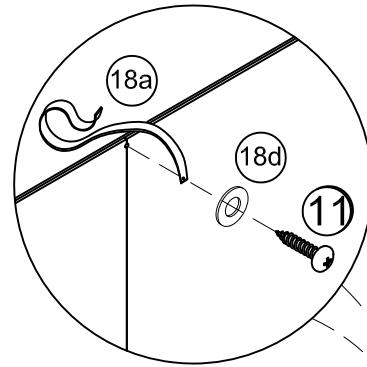
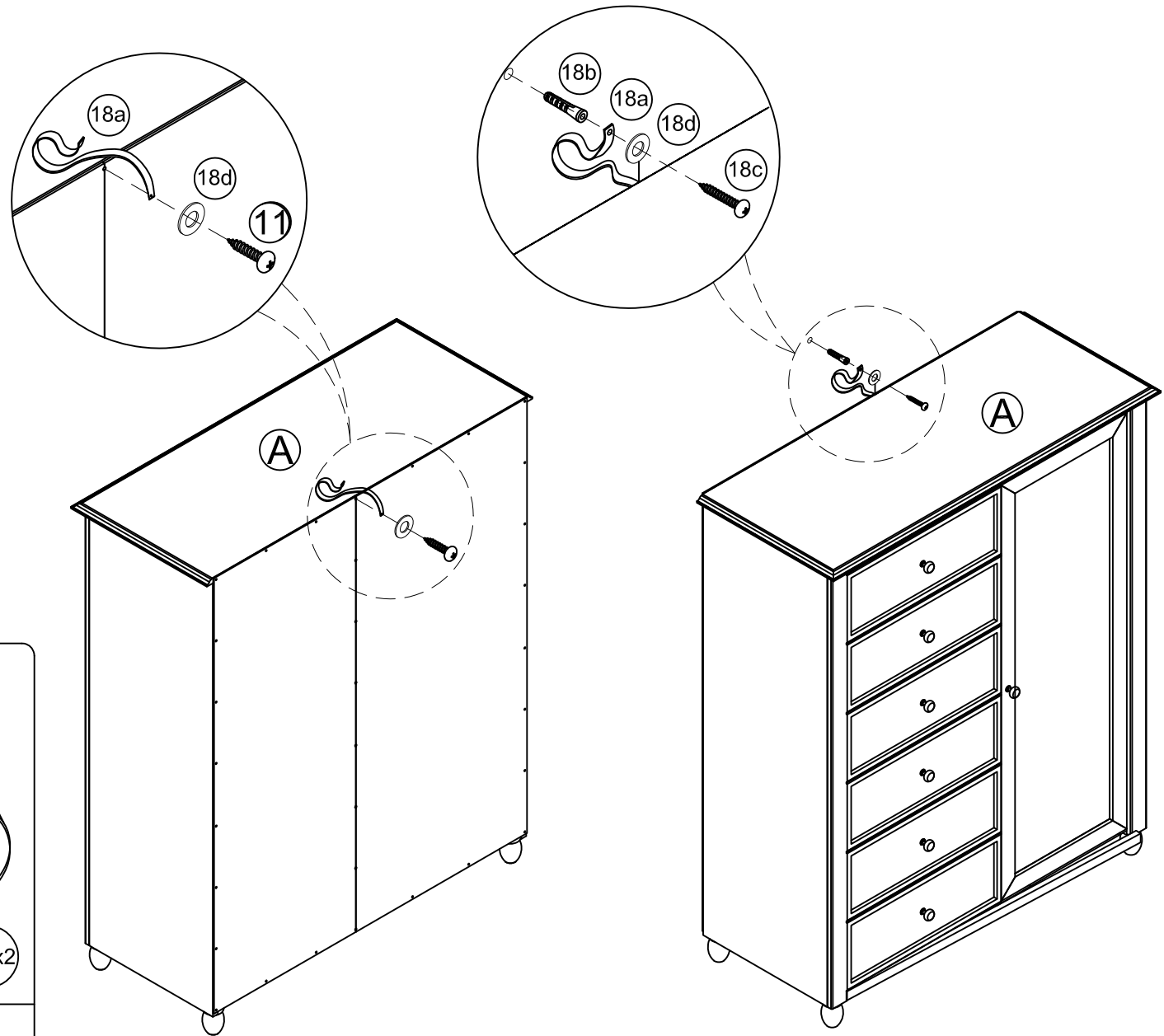

WEIGHT LIMITS:
LÍMITES DE PESO:

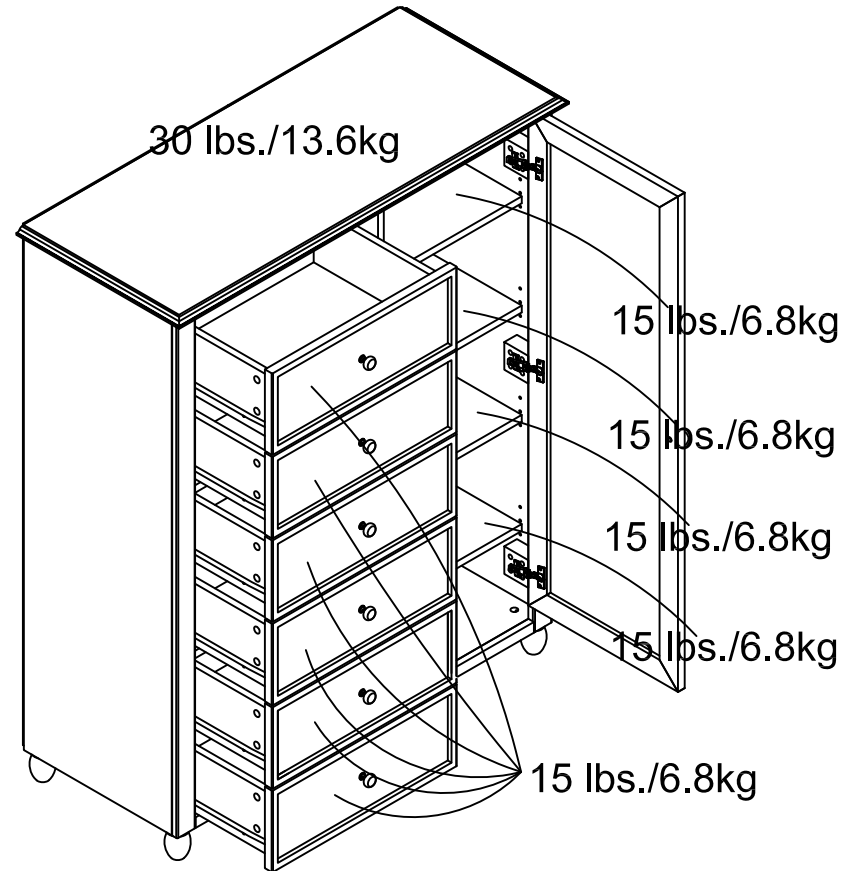
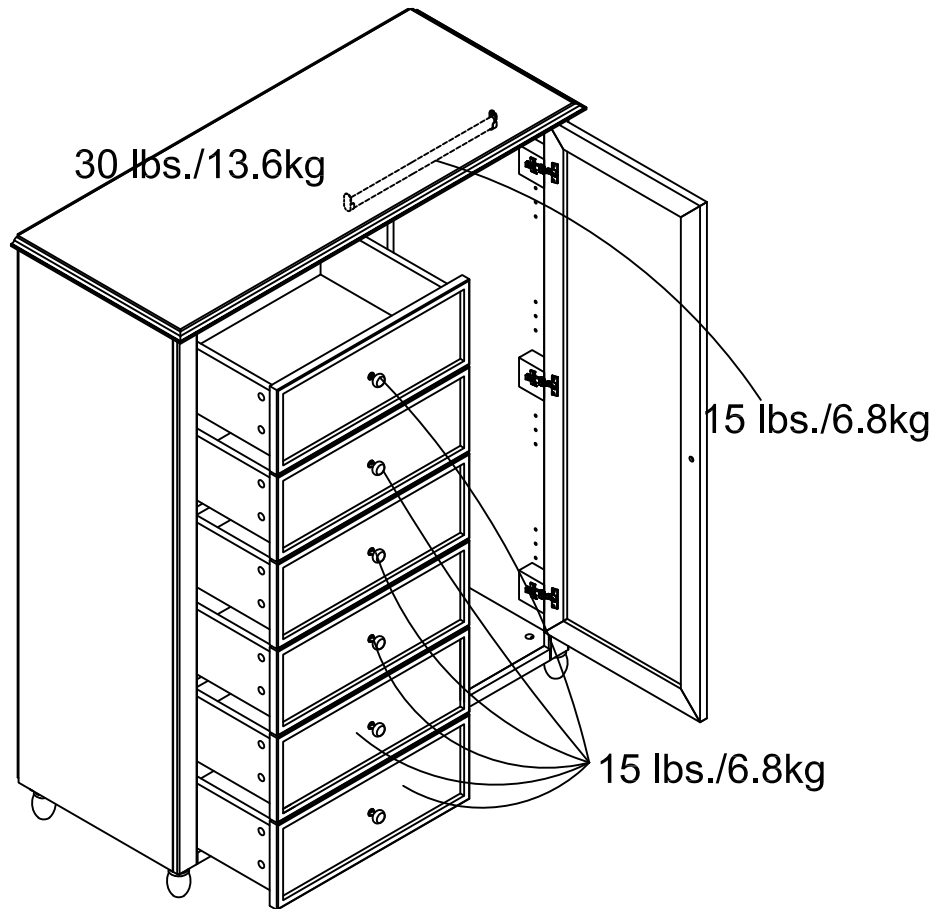

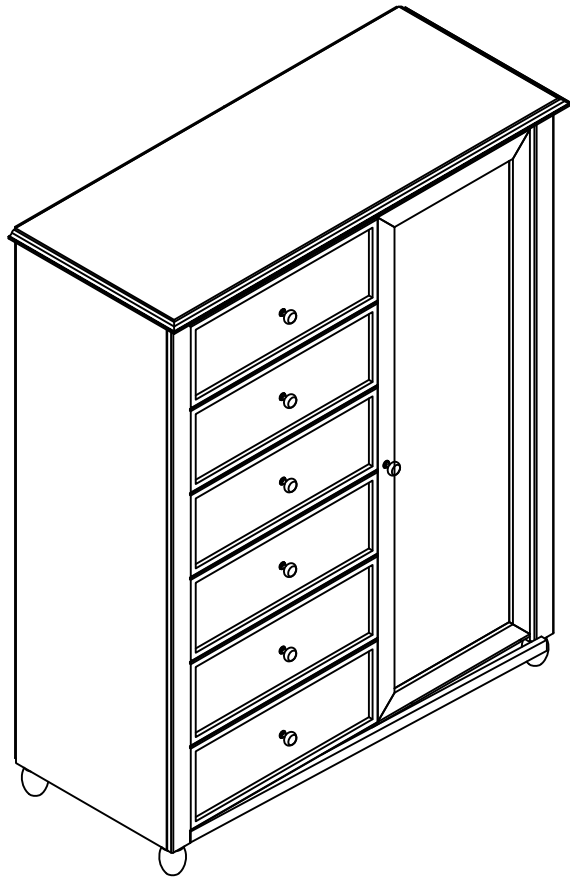

Enjoy Your Furniture
DISFRUTE DE SU MUEBLE

This unit has been designed to support the maximum loads shown.

Exceeding these load limits could cause sagging, instability, product collapse, and/or serious injury.

Esta unidad se ha diseñado para apoyar las cargas máximas mostradas.

Exceder estos límites de carga podría causar ceder, inestabilidad, derrumbamiento del producto, y/o lesión seria.

▲ WARNING

Please make sure that all objects are removed before moving the assembled unit.

The unit must be team lifted, not dragged or pushed. Failure to do so could cause instability, product collapse, and/or serious injury.

▲ ADVERTENCIA

Por favor mueva el mueble cuidadosamente con la ayuda de otra persona. Levante y mueva el mueble a su lugar. No lo arrastre o empuje, de lo contrario puede haber inestabilidad en el mueble y este puede colapsar u ocasionar graves lesiones.