

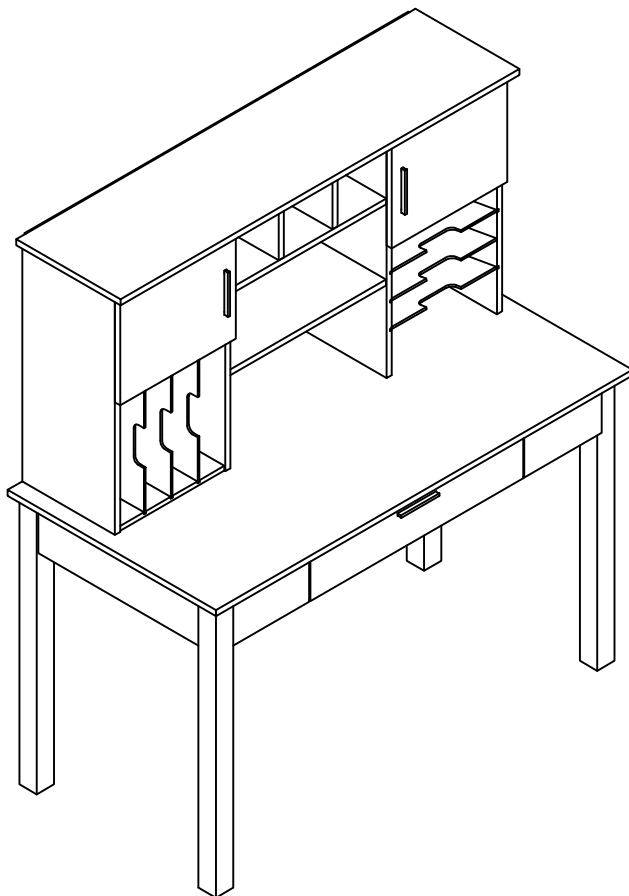

9345096



THIS INSTRUCTION BOOKLET CONTAINS **IMPORTANT** SAFETY INFORMATION. PLEASE READ AND KEEP FOR FUTURE REFERENCE.
ESTE FOLLETO DE INSTRUCCION CONTIENE INFORMACION **IMPORTANTE** DE SEGURIDAD. POR FAVOR LEA Y GUARDE PARA REFERENCIA FUTURA.

 **DO NOT RETURN PRODUCT TO THE STORE**
Individual stores do not stock parts.
NO DEVUELVA ESTE PRODUCTO A LA TIENDA
Las tiendas no almacenan partes.

Lot Number / Número de Lote: _____
Date Of Purchase / Fecha de Compra: ___/___/___

If a part is missing or damaged, call our toll-free customer service line. We will gladly ship your replacement parts FREE of charge.
Si faltan partes o piezas, o éstas están dañadas, llame gratis al teléfono de servicio al cliente. Con gusto le enviaremos las partes sin cargo alguno.

Need Parts or Assistance?
Necesitas partes o asistencia?

1-800-489-3351
or access our website
o visite nuestra página de internet

For prompt, reliable service please have your assembly manual ready.
Para obtener servicio rapido y confiable, por favor tenga esta manual a la mano.

Recommended # of people needed for assembly: 2
El número recomendado de personas necesarias para el montaje: 2

Thank you for purchasing from Altra Furniture.
Visit www.altrafurniture.com to view the limited warranty valid in the U.S. and Canada.

ALTRA FURNITURE CUSTOMER SERVICE

Before starting - Antes de empezar.

- Read each step carefully before starting. It is very important that each step of instruction is performed in the correct order. If these steps are not followed in sequence, assembly difficulties will occur.
Leer con cuidado cada paso antes de empezar. Es muy importante de ejecutar cada paso en el orden correcto. Si los pasos no están ejecutados en secuencia, ocurrirá dificultades en el montaje.
- Make sure all parts are included. Most board parts are labeled or stamped on the raw edge.
Asegurar que todas las piezas son incluidas. La mayoría de las tablas tienen las etiquetas o los sellos en el lado sin acabado.
- Work in spacious area, preferably on a carpet, near the place the unit will be used.
Trabajar en una área espaciosa, preferible sobre alfombra, cercas del lugar donde se va a usar el mueble.
- Have the following tools close at hand.
Tener las herramientas siguientes cerca de la mano.
- Do not use power tools to assemble your furniture. Power tools may strip or damage the parts.
No use herramienta eléctrica para montar su unidad. Las herramientas eléctricas pueden dañar las piezas.

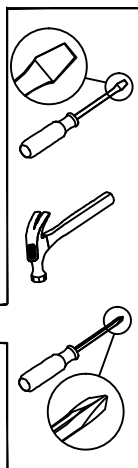

Gracias por haber comprado de Altra Furniture.
Visitar www.altrafurniture.com para mirar la garantía limitada válida solamente en U.S.A y Canada.

SERVICIO A LA CLIENTE DE ALTRA FURNITURE



Call us at:
Llamar a:

1-800-489-3351
(in U.S.A. only)
(Solo en U.S.A)



Fax:
Fax:

1-636-745-1005

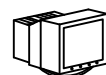

Visit our Website:

Visitar nuestro website: www.altrafurniture.com



Write to:
Escribir a:

ALTRA FURNITURE
410 East 1st Street South Wright City, MO 63390 USA
Attn: Service Dept.

9:00am - 5:00pm

Monday - Friday	8:00am - 8:00pm	Saturday	9:00am - 5:00pm
Central Time		Central Time	
Lunes - Viernes	8:00am - 8:00pm	Sábado	9:00am - 5:00pm
Tiempo Central		Tiempo Central	

HELPFUL HINTS

- Visit our website for assembly video clips.
- Identify, sort and count the parts before attempting assembly.
- Call our toll free number if you need assistance identifying parts.
- Compression dowels are tapped in with a hammer.
- Slides have lips only on the right side.
- Cam locks that are properly fastened on a horizontal board will face toward the center of the unit, on a vertical board the point on the lock will face the bottom.
- Back panels provide stability and support. Use all the nails provided.
- When tapping nails into a board, be sure there are equal margins on all sides to square the unit.
- Units without the back panel installed may collapse.
- Clean the product with your favorite furniture polish and a soft cloth. **DO NOT USE** harsh chemicals or abrasive cleaners.
- Move your new furniture carefully, with two people lift and carry the unit to its new location.
- Never push, drag or scoot your furniture (especially on carpet).
- Your furniture can be disassembled and reassembled to move.
- Additional parts are available for a nominal fee.

NOTES UTILES

- Visitar nuestro website para mirar los videos cortos del montaje.
- Identificar, clasificar y contar las piezas antes de intentar el montaje.
- Llamar gratis a nuestro número de servicio si necesite ayuda con identificar las piezas.
- Las clavijas de compresión se taladran con un martillo.
- Las correderas sólo tienen las protrusiones en el lado derecho.
- Las cerraduras de leva que se atan propiamente en una tabla horizontal se puntan al centro de la unidad, y las en una tabla vertical se puntan al fondo.
- Los paneles traseros se mantienen la estabilidad. Usar todos los tornillos proporcionados.
- A taladrar los tornillos en una tabla, asegurarse que hay márgenes iguales en todos los lados para cuadrar la unidad.
- Las unidades sin panel trasero pueden derrumbarse.
- Limpiar la unidad con su pulimento favorito de mueble y una tela suave. **NO UTILIZAR** productos con químicos duros o abrasivos.
- Mover su mueble nuevo cuidadosamente, con dos personas levantar la unidad a su nuevo lugar.
- Nunca empujar o arrastrar su mueble (especialmente en alfombra).
- Poderse desmontar y volver a montar su mueble de para mover.
- Piezas adicionales están disponibles para una cuota nominal.

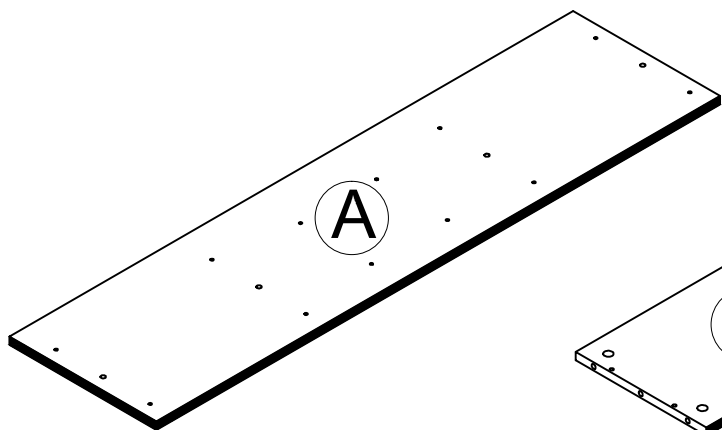

Top
Dessus
T9345096010

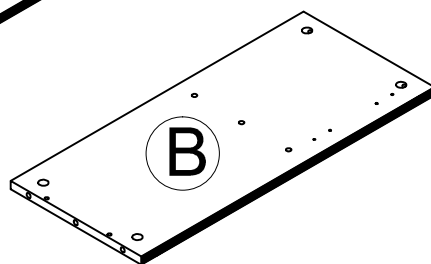

Left side panel
Panneau gauche
T9345096020

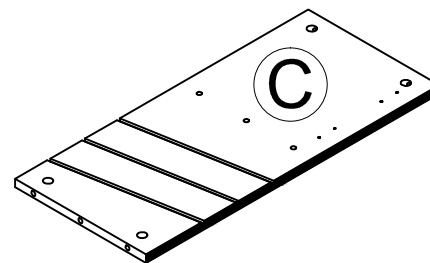

Right side panel
Panneau droit
T9345096030

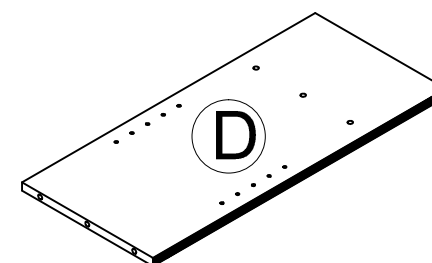

Left partition panel
Cloison gauche
T9345096040

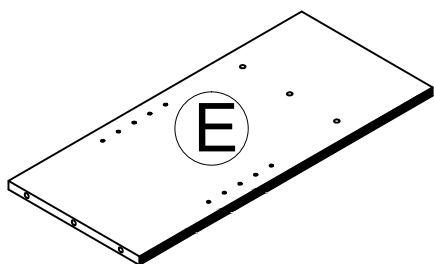

Right partition panel
Cloison droit
T9345096050

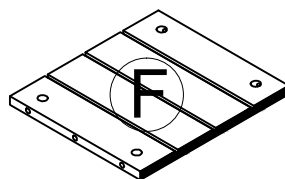

Left fixed shelf
Tablette stationnaire gauche
T9345096060

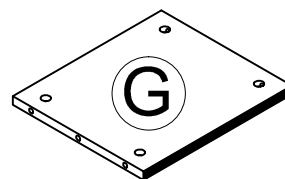

Right fixed shelf
Tablette stationnaire droit
T9345096070

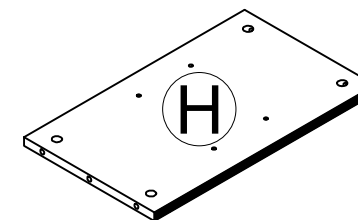

Fixed shelf
Tablette stationnaire
T9345096080

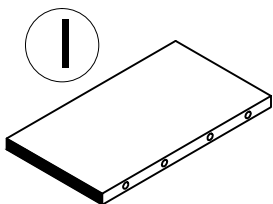

Middle partition (2)
Partición izquierda (2)
T9345096090

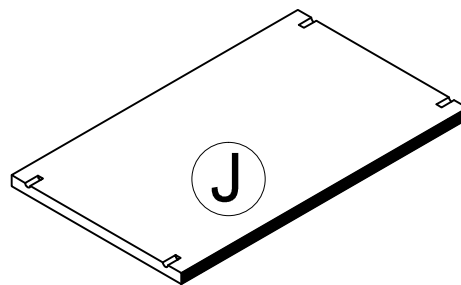

Adjustable shelf
Repisa ajustable
T9345096100

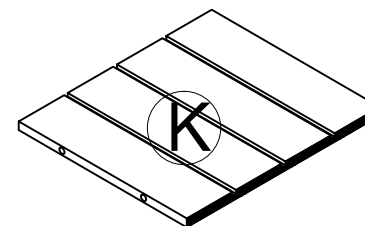

Bottom panel
Panel base
T9345096110

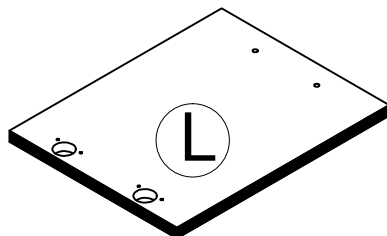

Door (2)
Porte gauche (2)
T9345096120

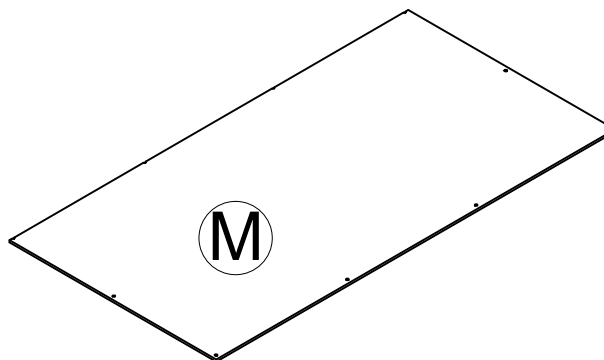

Side back panel (2)
Panel trasero (2)
T9345096130

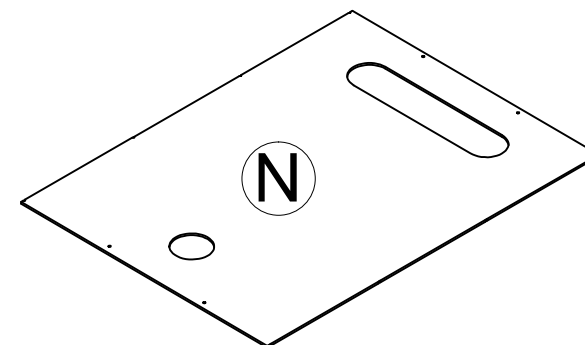

Back panel
Panel trasero
T9345096140

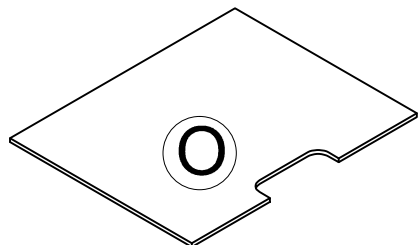

Left extension board (3)
 Tablette gauche réglable (3)
T9345096150

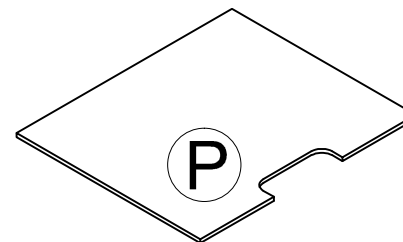

Right adjustable board (3)
 Tablette droite réglable (3)
T9345096160

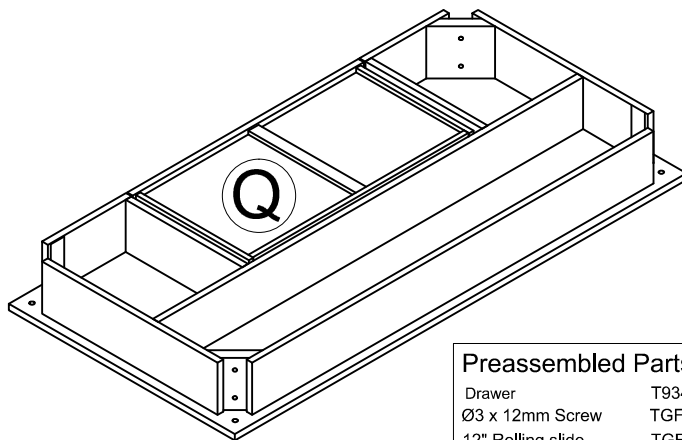

Frame
 Panneau supérieur
T9345096170

Preassembled Parts	
Drawer	T9345096171
Ø3 x 12mm Screw	TGF0030
12" Rolling slide	TGF0169

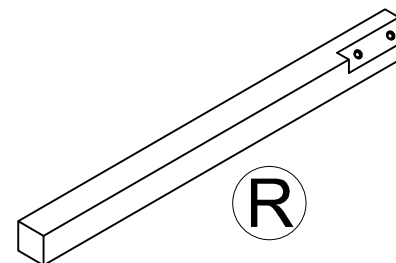

Leg(4)
 Pied(4)
T9345096180

PARTS -PIECES

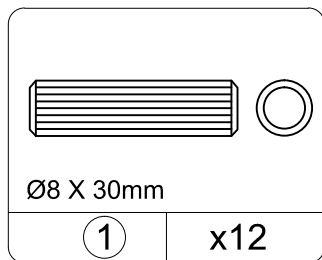

Wood dowel
Clavija de madera
TGF0003

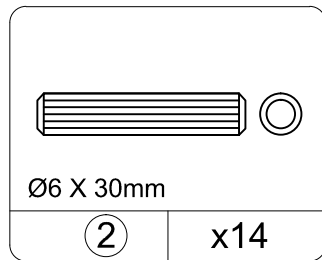

Wood dowel
Clavija de madera
TGF0100

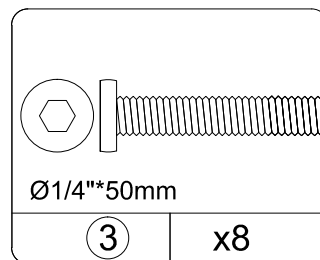

Bolt
Boulon
TGF0170

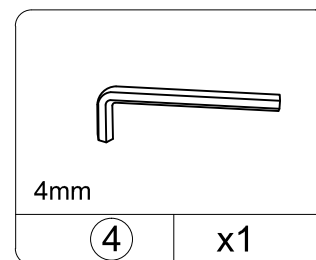

Hex key
Clef hexadécimale
TGF0021

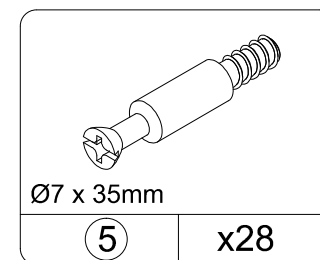

Cam bolt
Tornillo de rosca
TGF0001

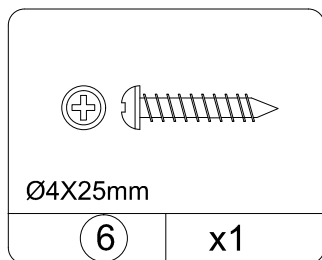

Screw
Tornillo
TGF0059

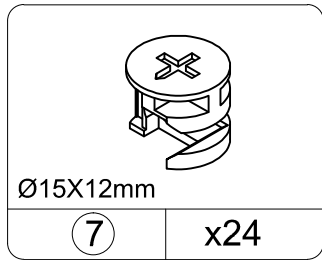

Cam lock
Tornillo de rosca
TGF0002

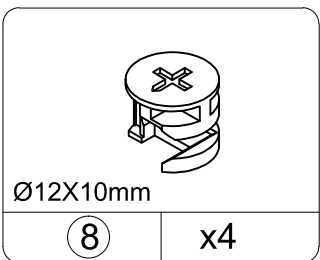

Cam lock
Tornillo de rosca
TGF0034

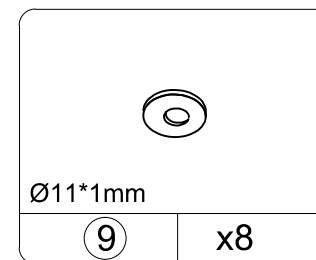

Washer
Rondelle
TGF0118

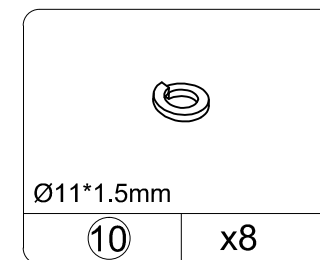

Spring washer
Rondelle
TGF0119

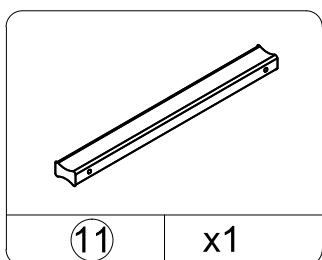

Handle
Tirador
TGF0165

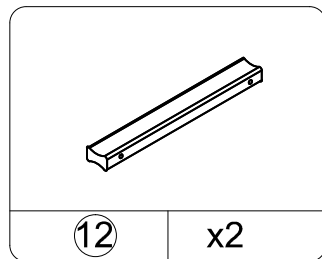

Handle
Tirador
TGF0167

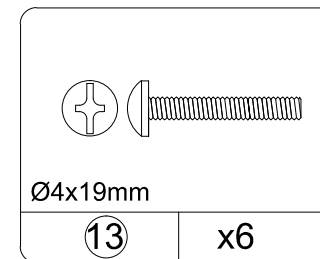

Bolt
Tornillo
TGF0166

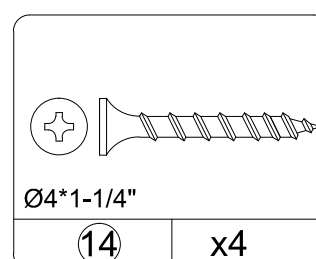

Screw
Tornillo
TGF0032

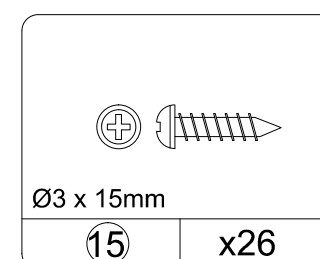

Screw
Tornillo
TGF0060

PARTS -PIECES

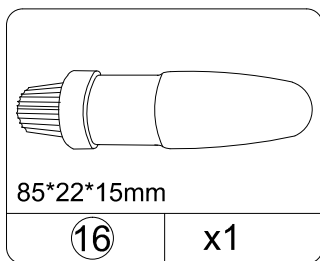

Glue
La cola
TGF0023

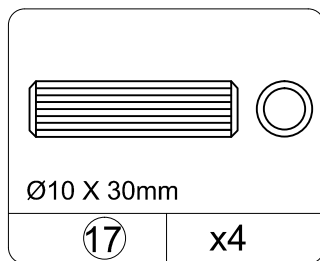

Wood dowel
Clavija de madera
TGF0168

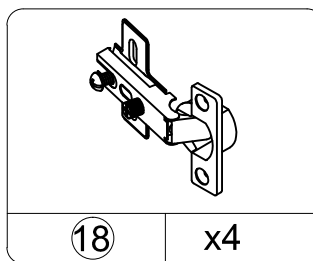

Euro hinge
Charnière euro
TGF0092

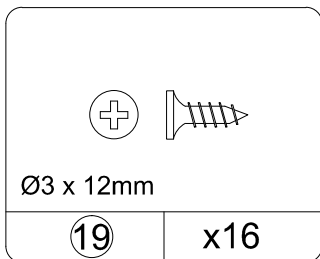

SCREW
Vis
TGF0030

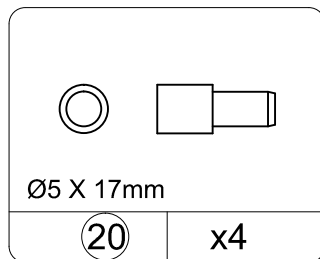

Shelf pin
Support pour tablette
TGF0035

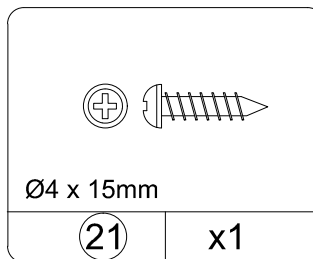

Screw
Tornillo
TGF0060

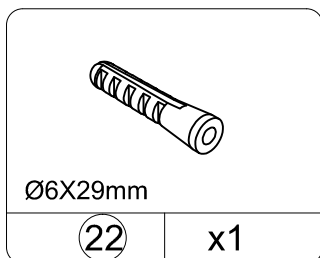

Wall anchor
Ancla de pared
TGF0041

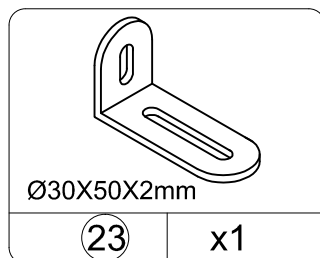

Wall bracket
Soporte para la
TGF0042

This illustration shows how the CAM fastening system works.
Esta ilustración muestra el sistema de fijación de leva y como funciona.

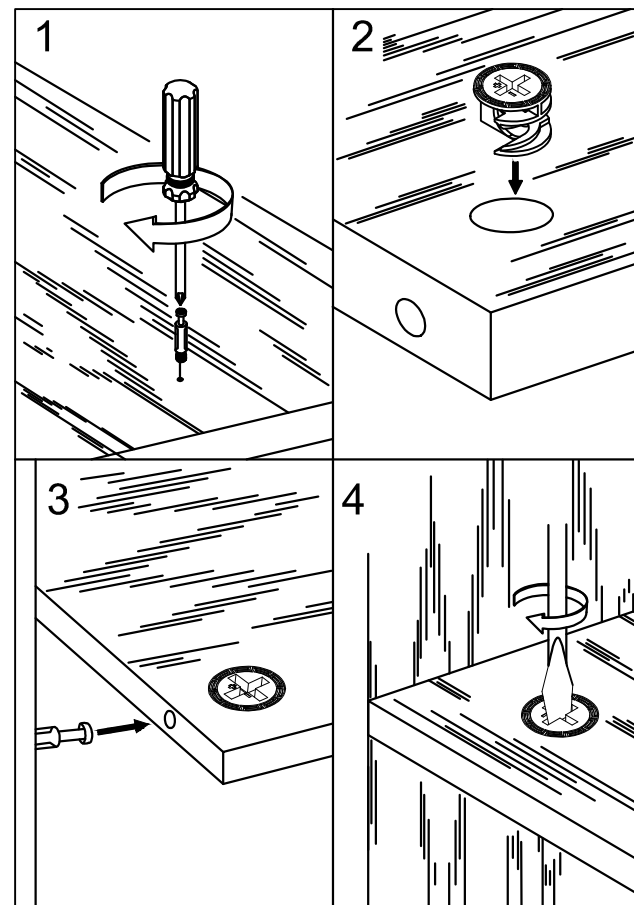

To view a video on how the CAM fastening system works, download a free QR-reader on your smartphone, then scan the code.

Para ver un video de como funciona el sistema de sujeción CAM, descargue una aplicación gratis que podra ver en su teléfono movil, entonces escnee el código.

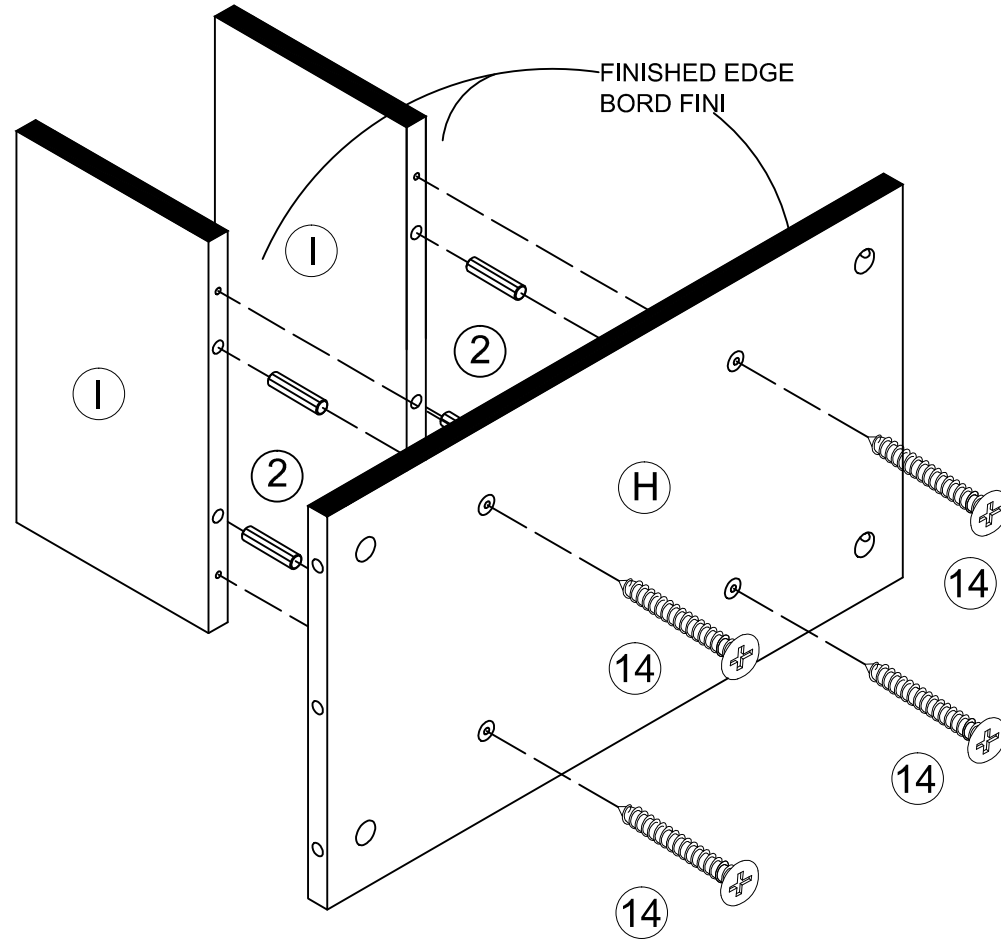
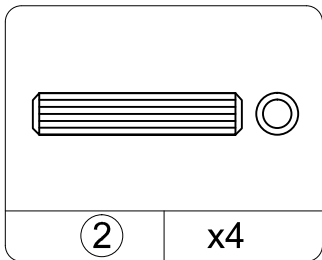
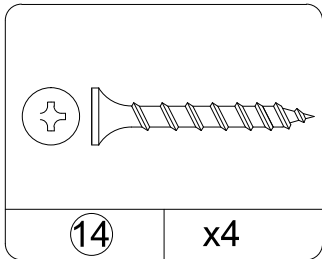
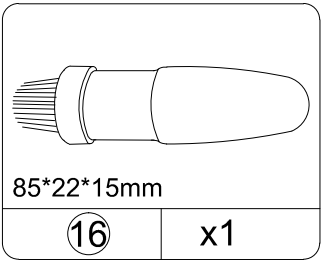

2

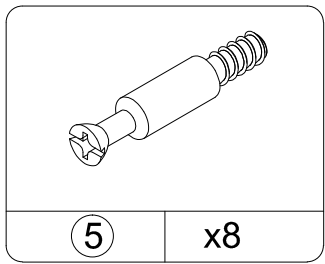
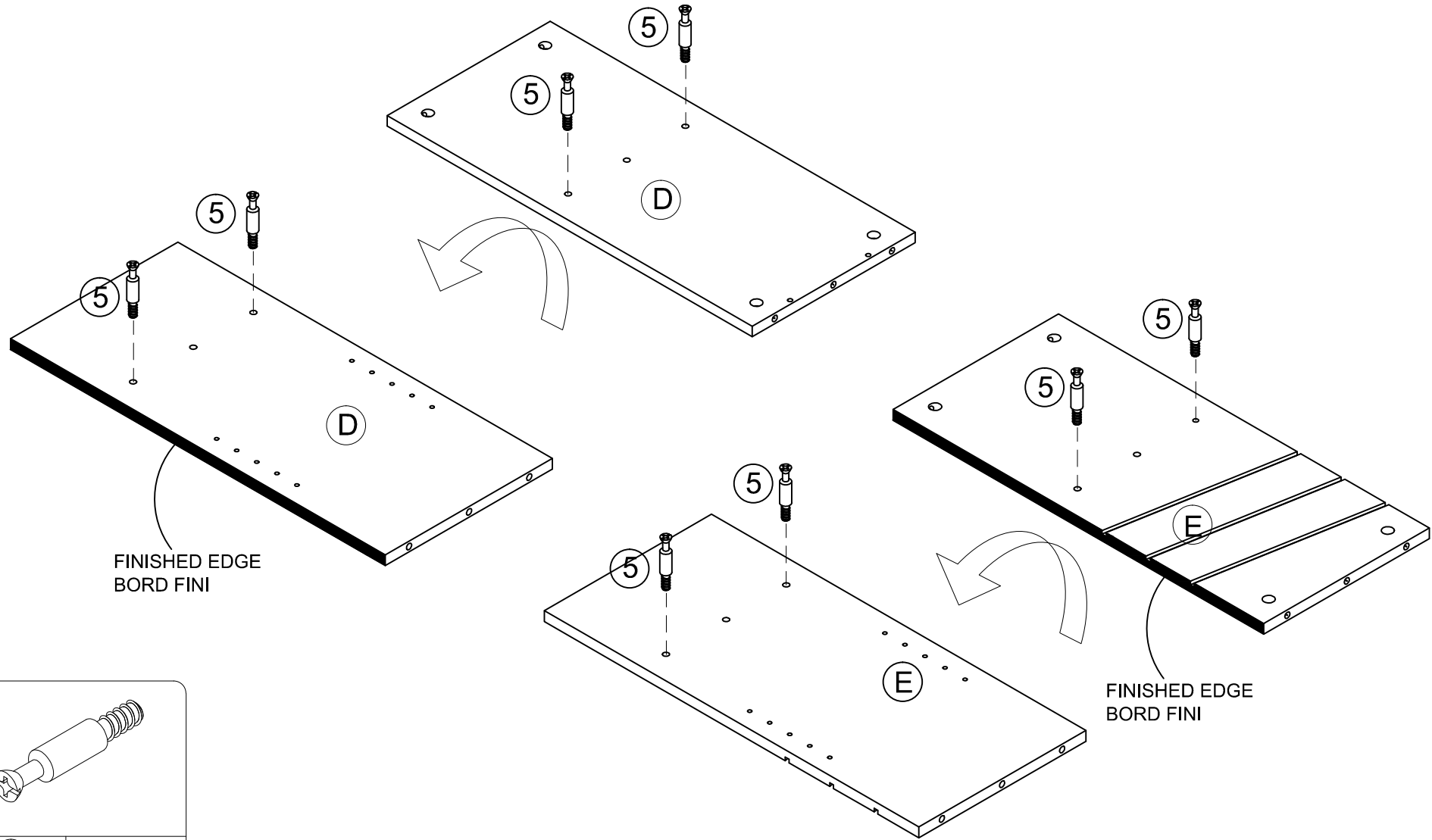

3

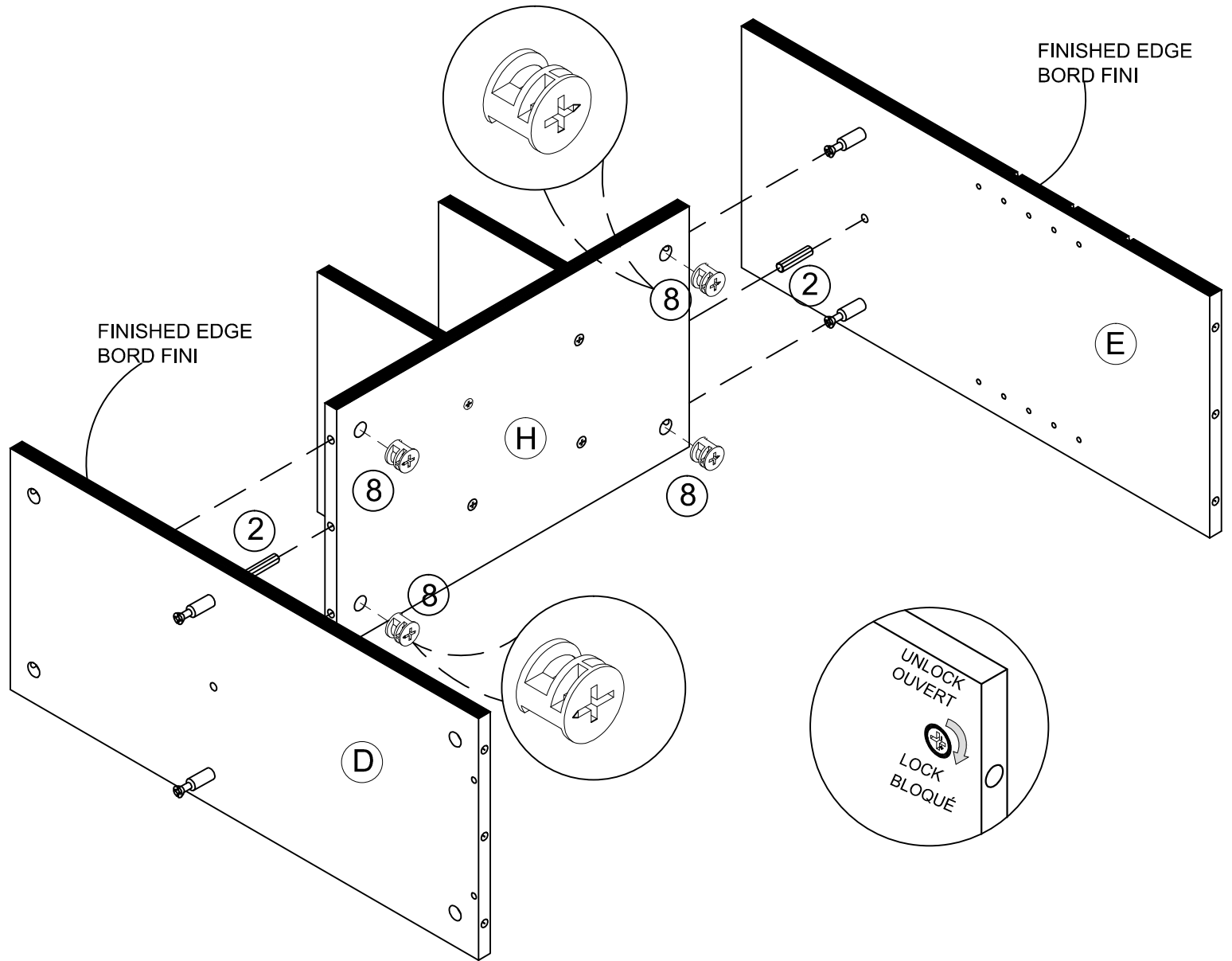
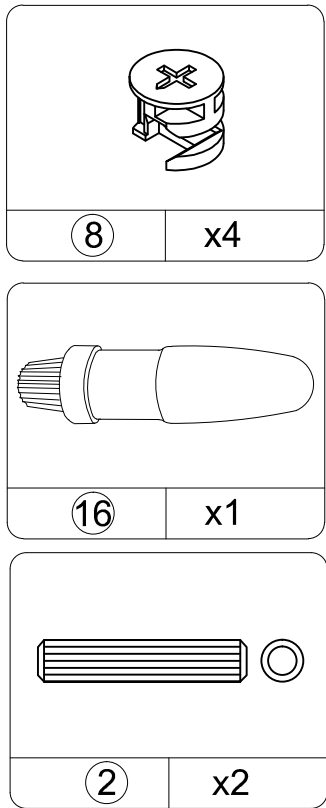

4

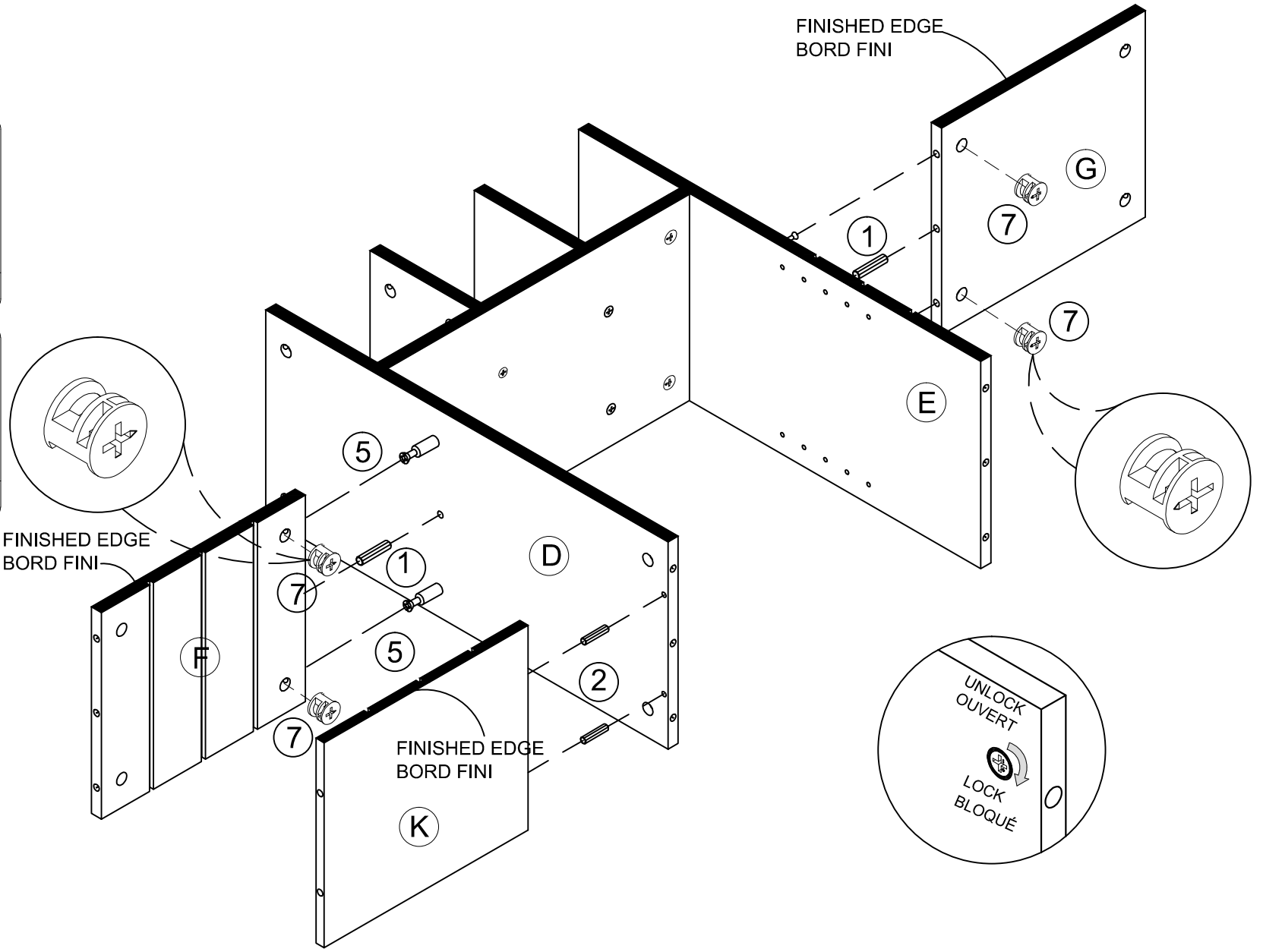
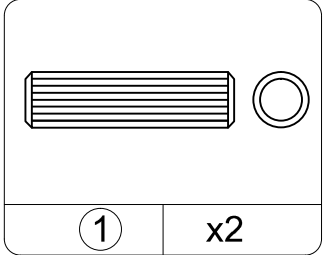
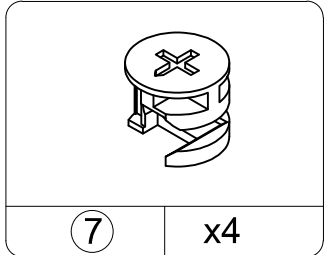
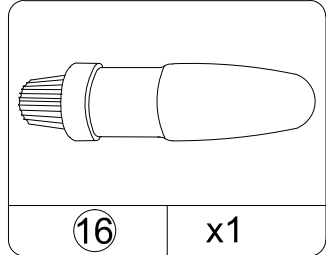
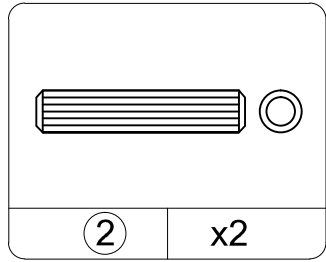

5

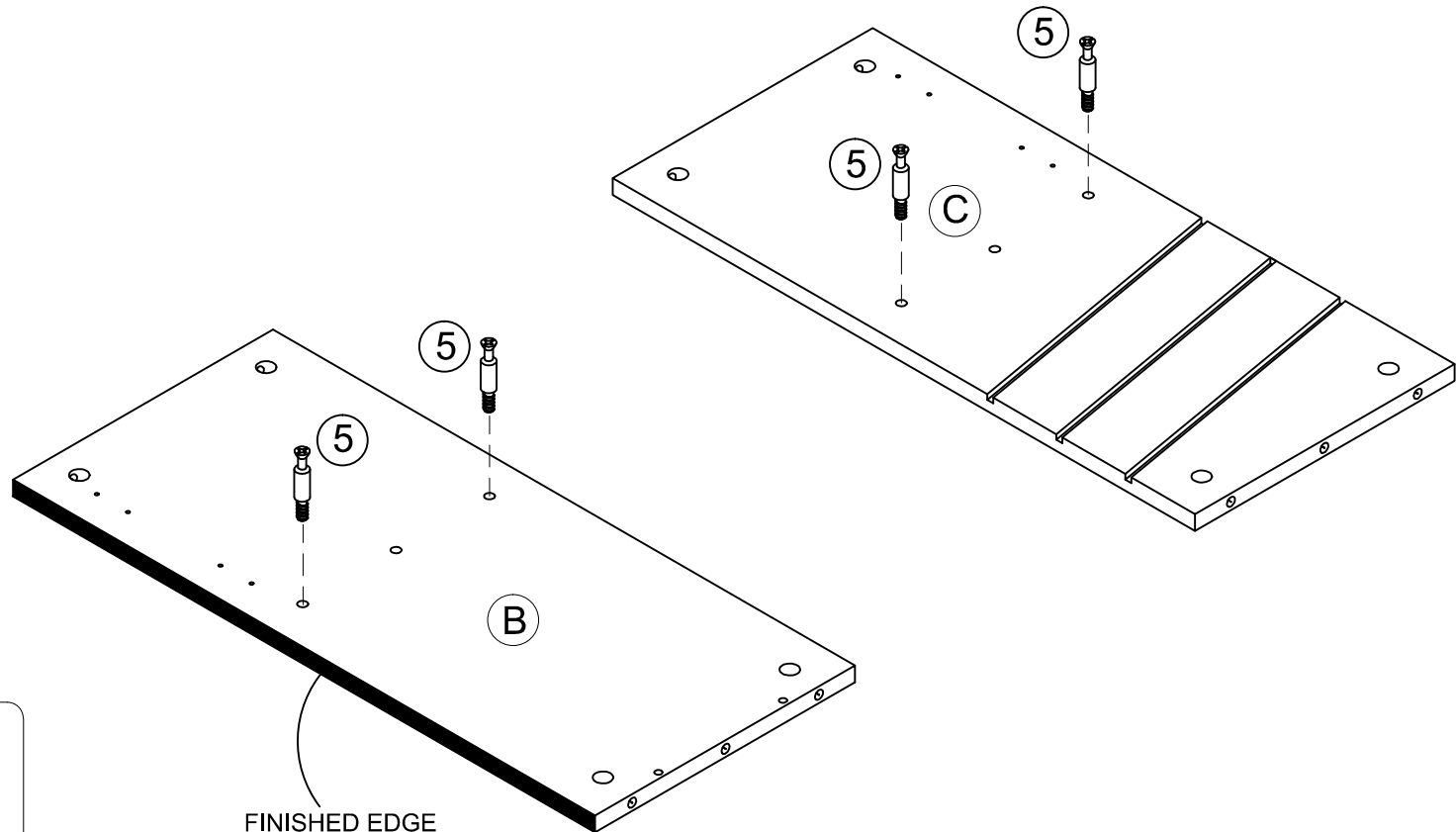

FINISHED EDGE
BORD FINI

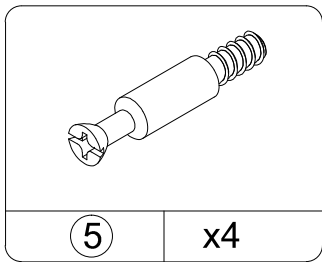

6

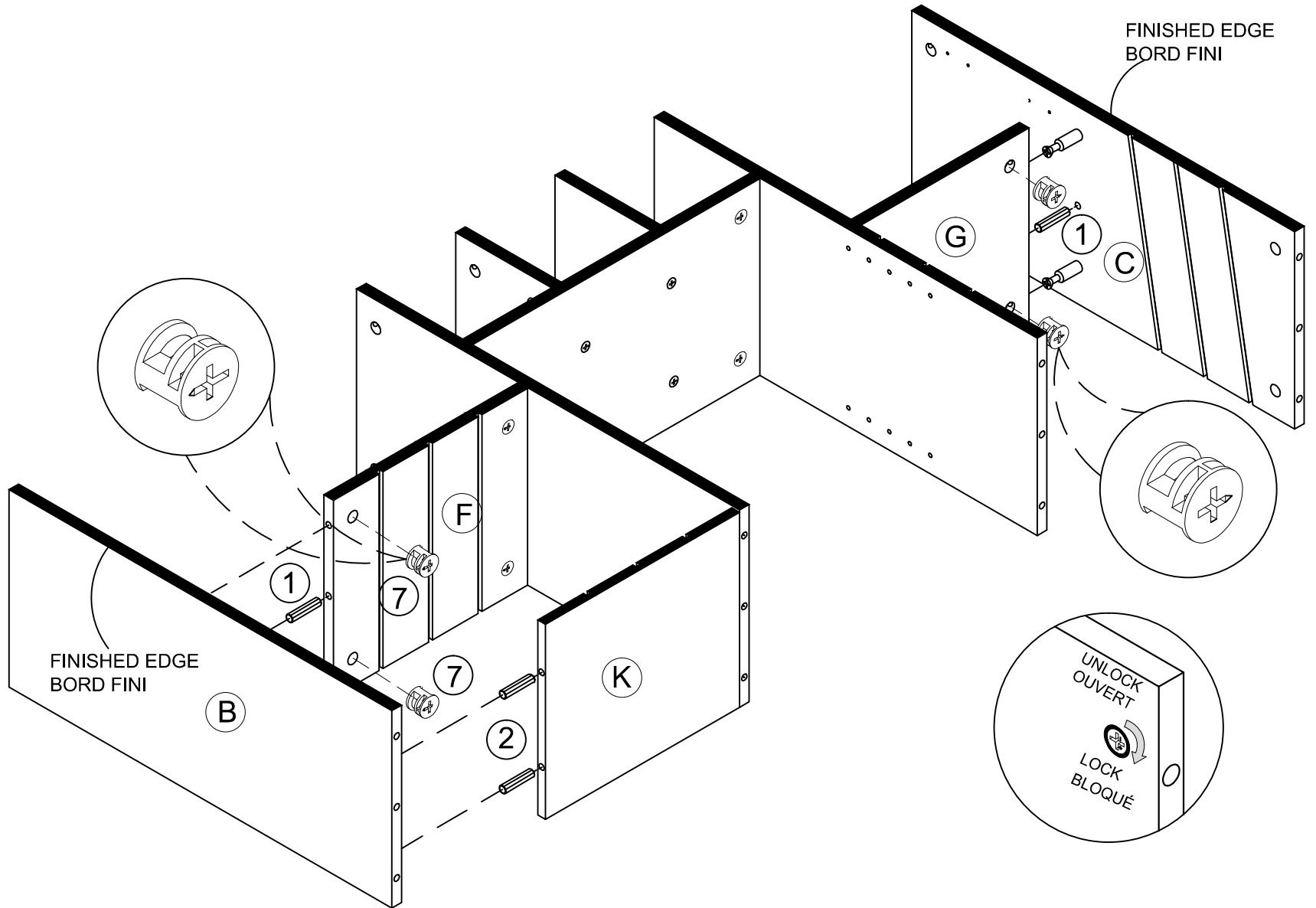
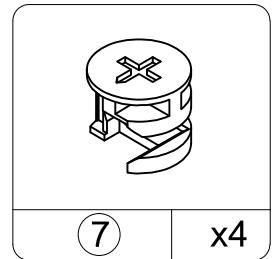
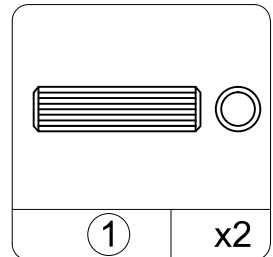
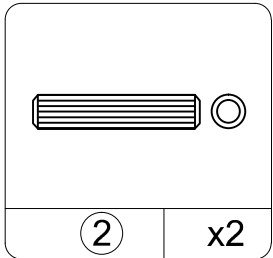
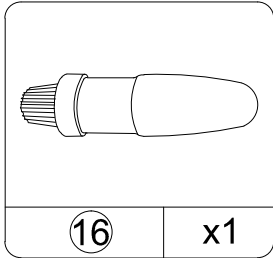

7

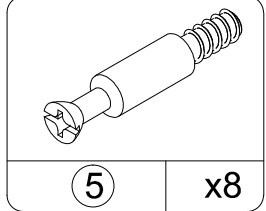
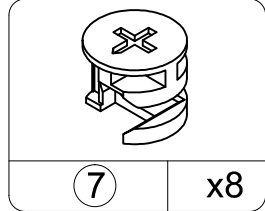
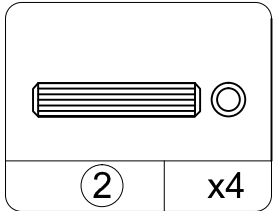
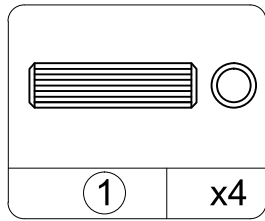
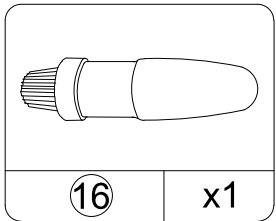
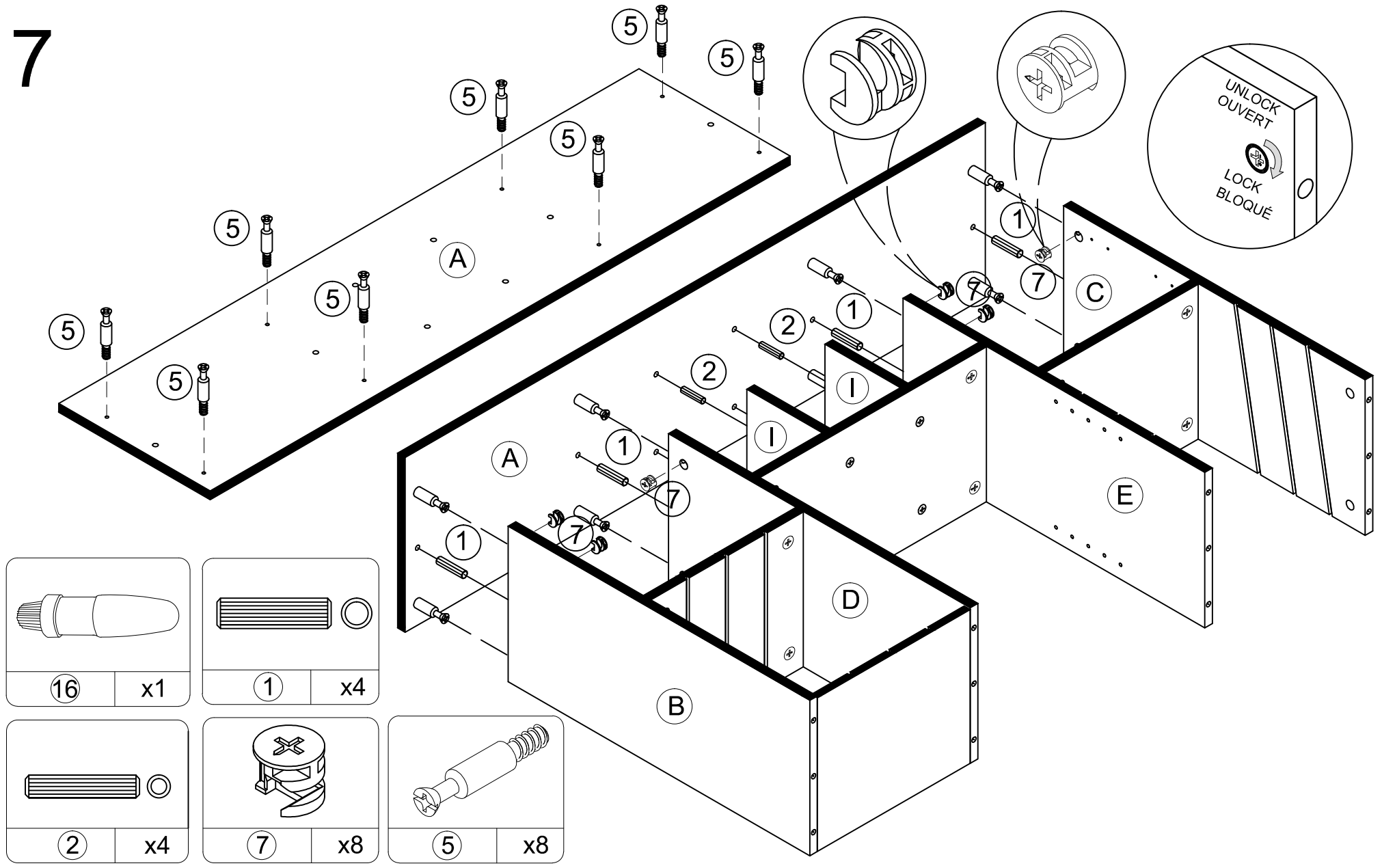

8

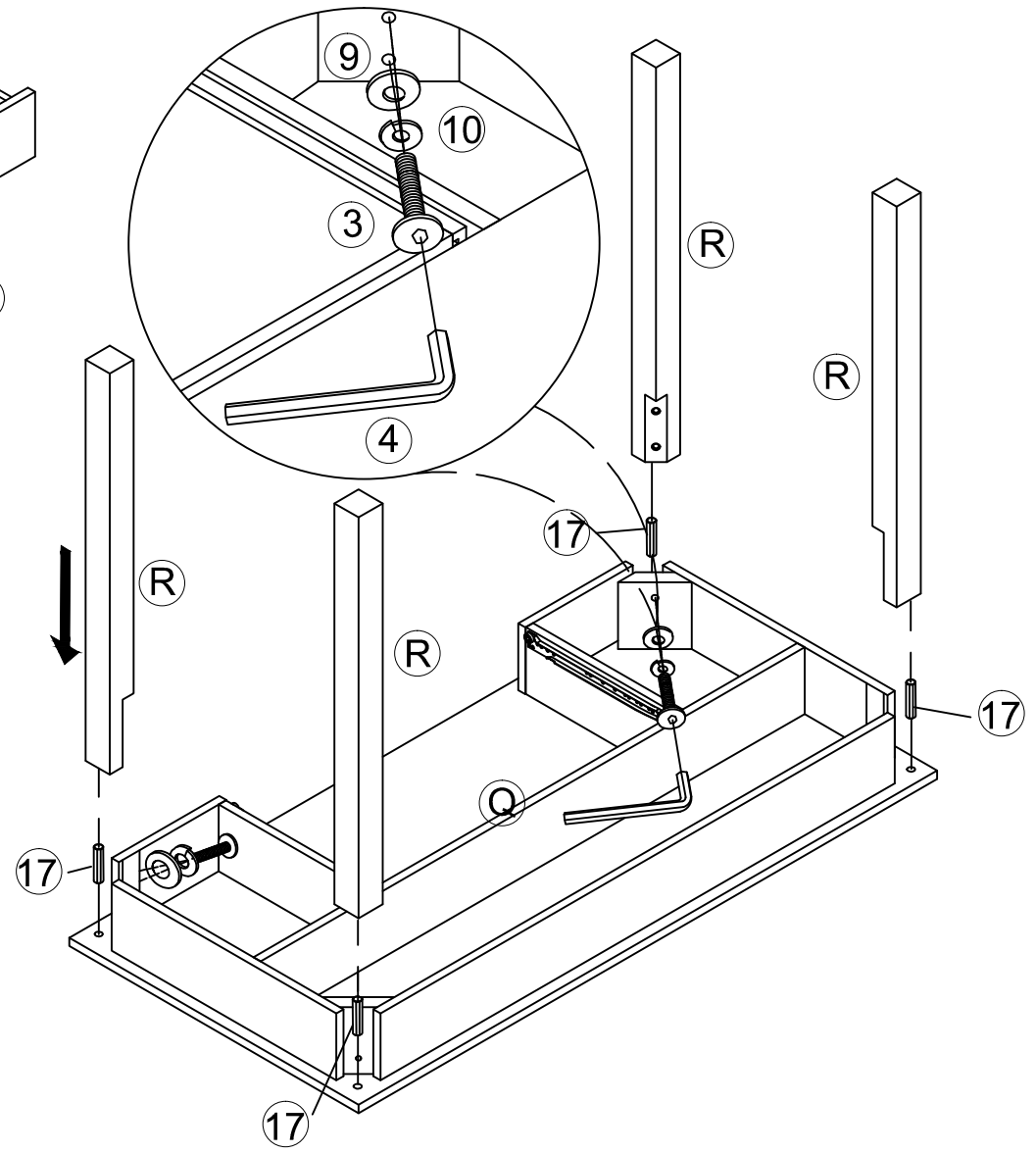
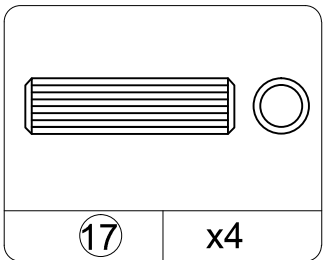
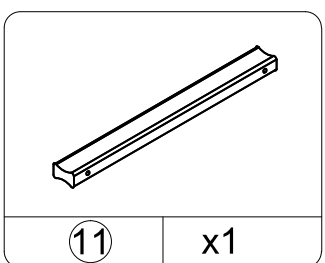
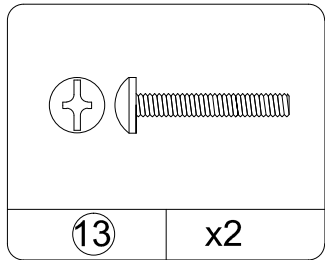
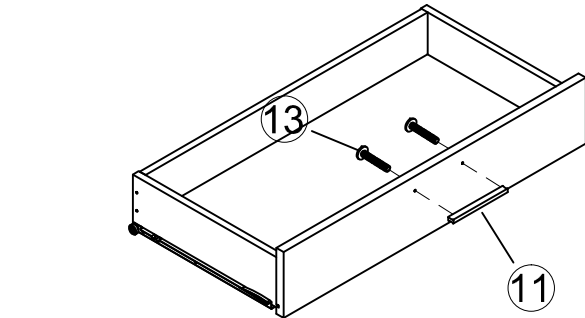
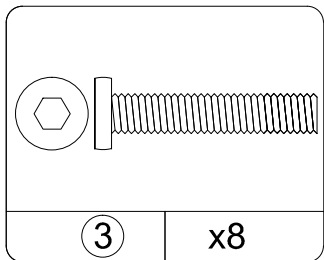
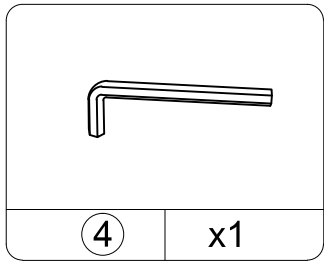
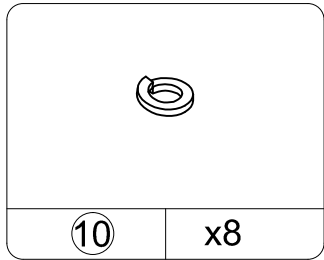
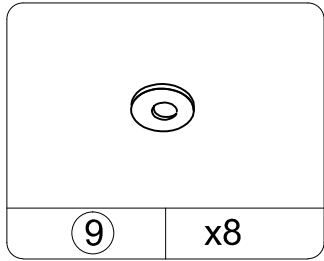

9

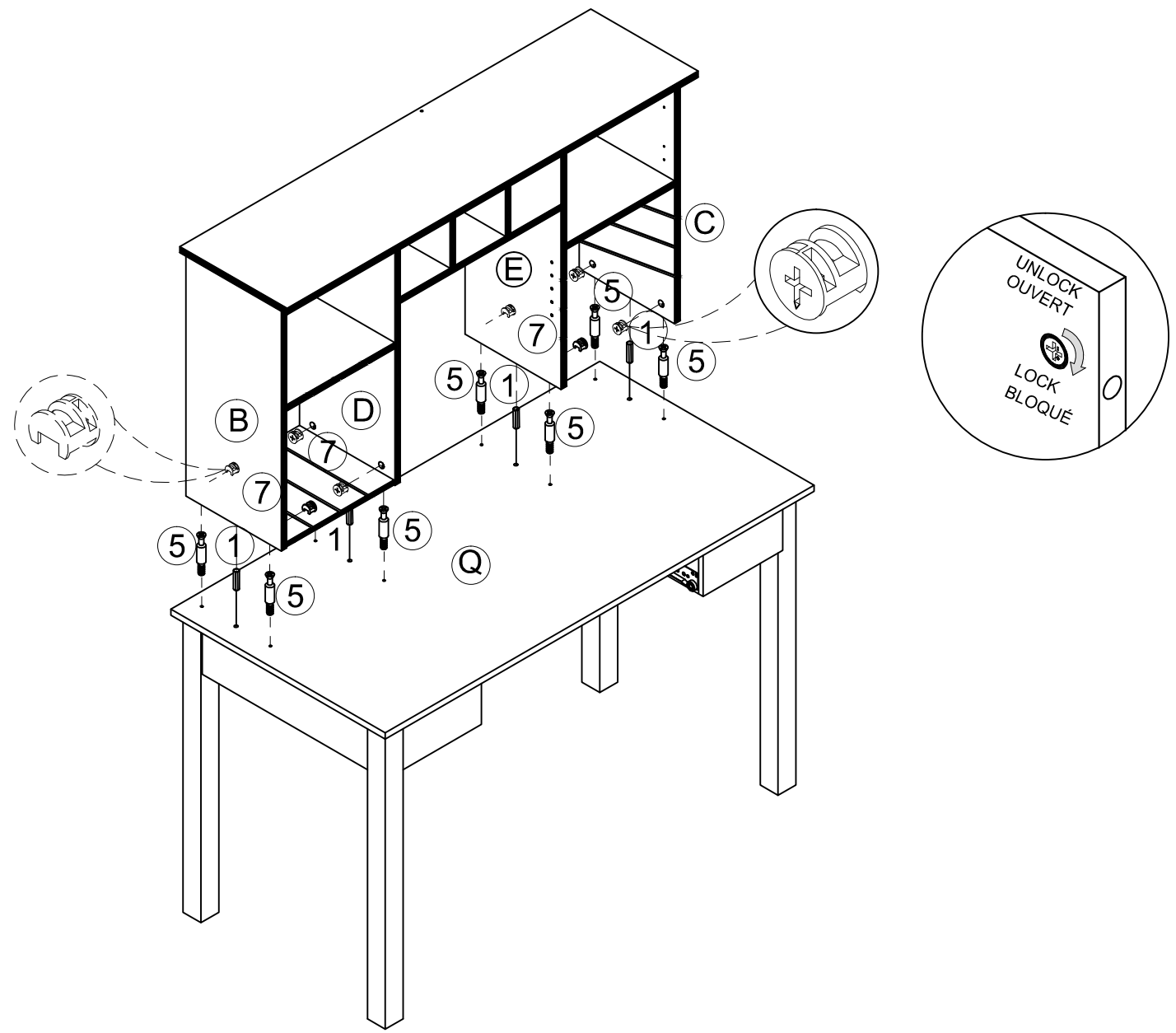
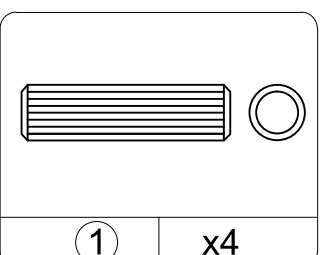
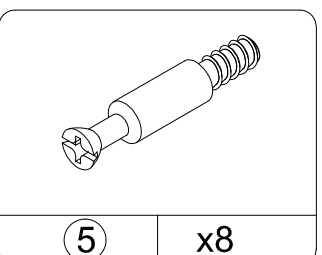
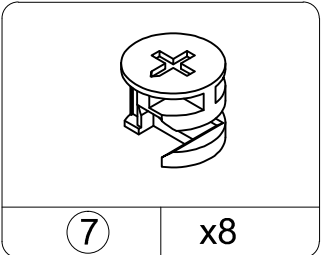
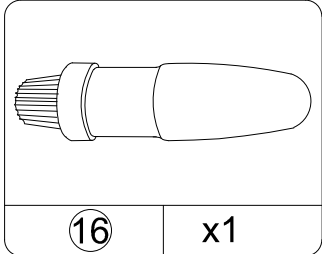

10

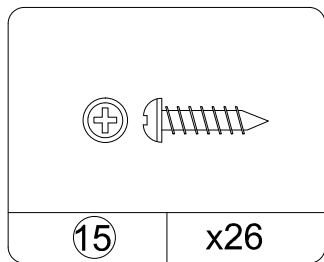
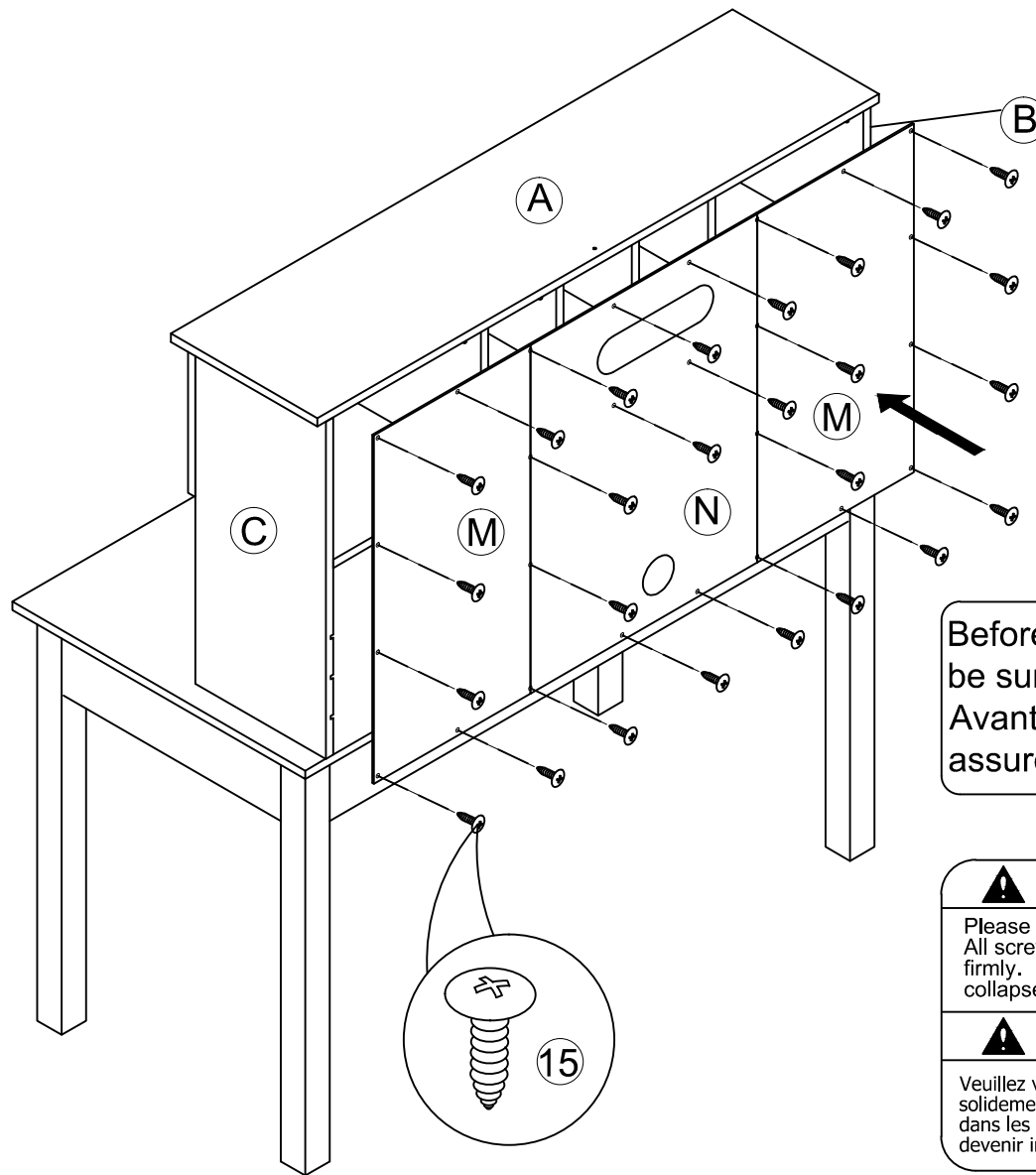

Before attaching the back panel be sure that the unit is at 90°.
Avant de fixer le panneau arrière, assurez-vous que l'unité est à 90°.

⚠ WARNING
Please make sure that the backs are attached securely. All screws must be driven into the parts straight and tightened firmly. Failure to do so could cause instability, product collapse, and/or serious injury.

⚠ AVERTISSEMENT:
Veuillez vous assurer que les panneaux arrière sont fixés solidement. Toutes les vis doivent être insérées perpendiculairement dans les pièces et serrées fermement. Sinon, le meuble peut devenir instable, s'effondrer et/ou causer des blessures graves.

11

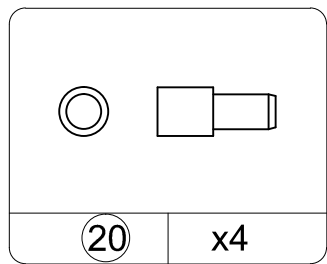
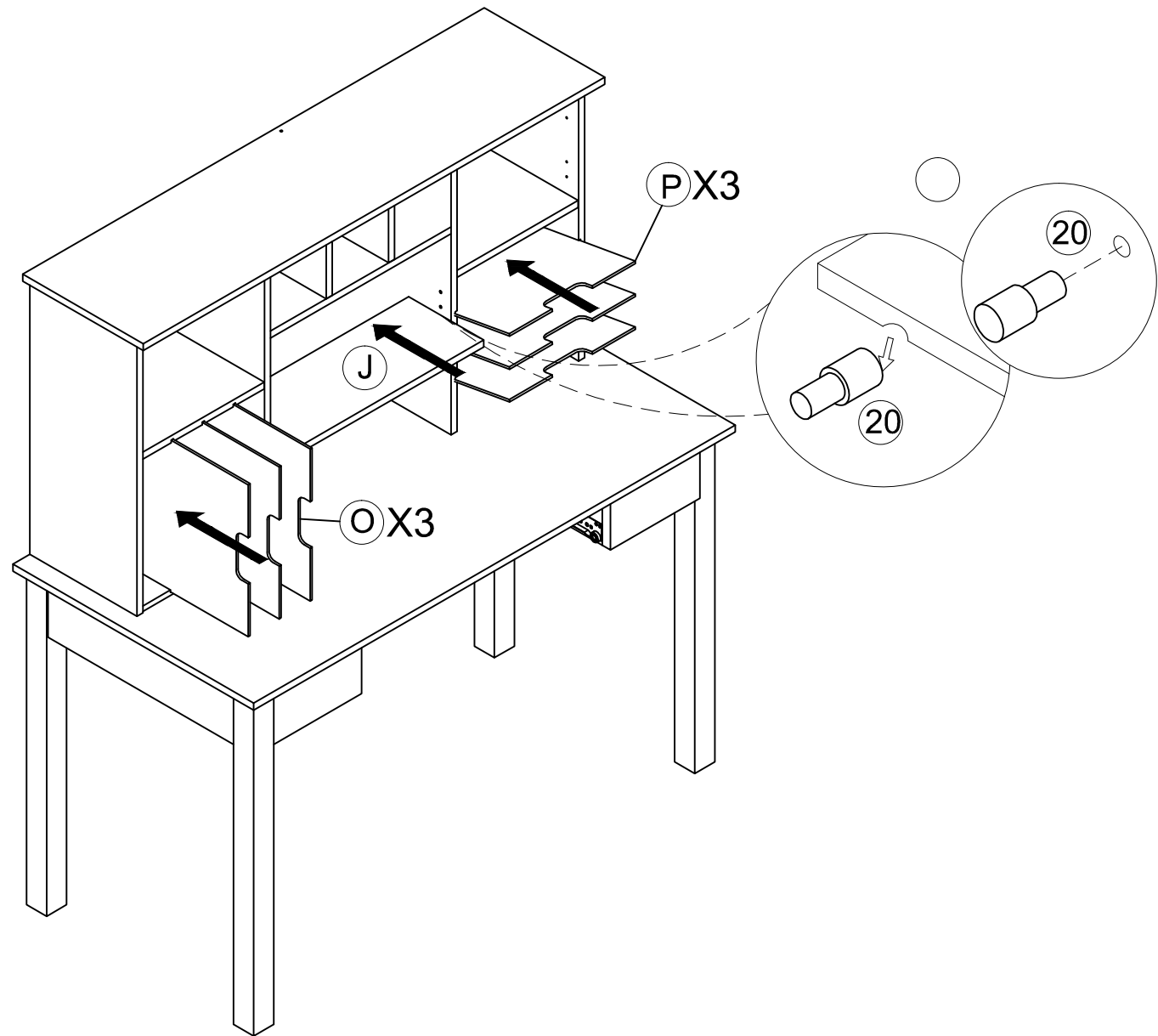

12

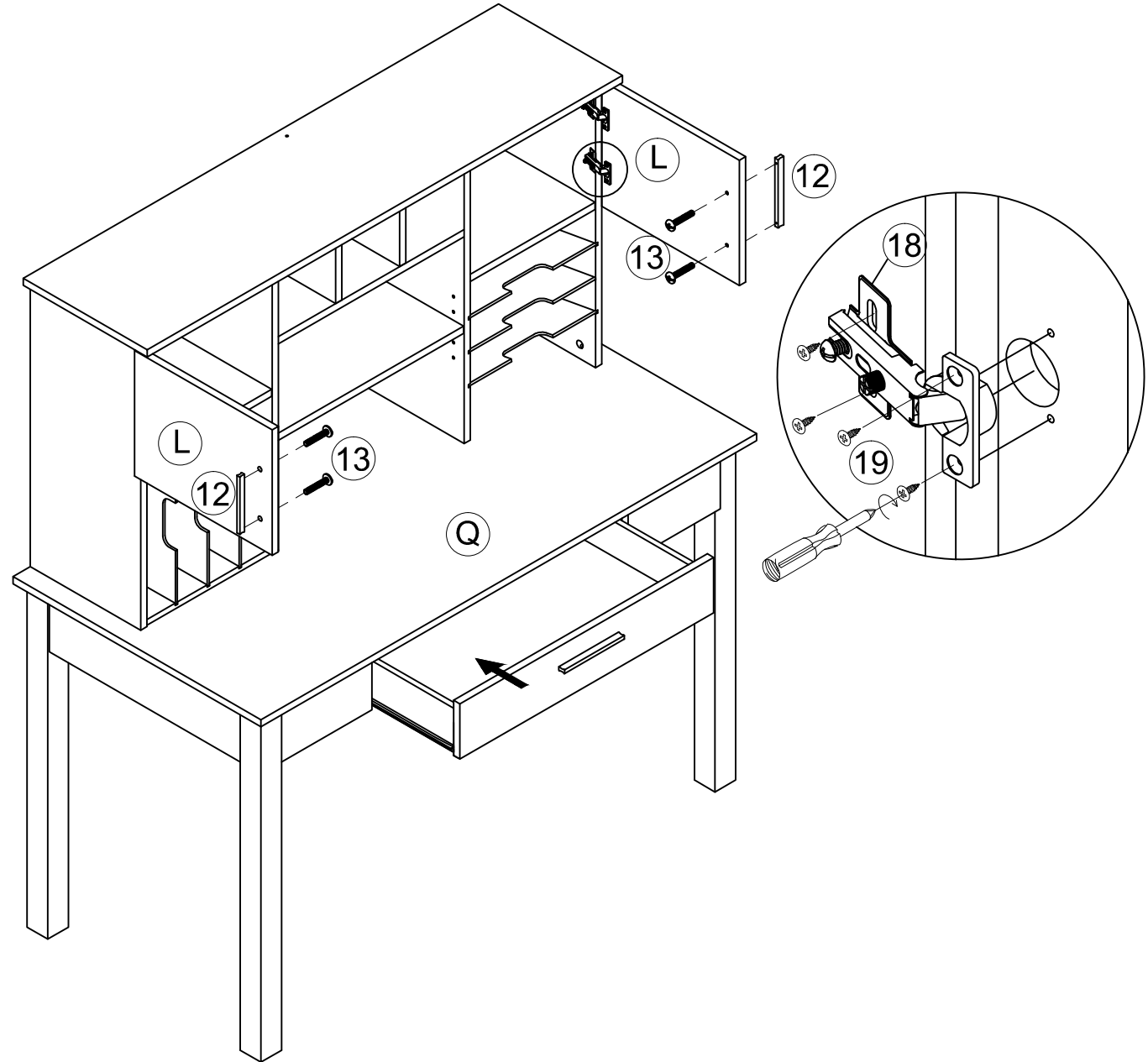
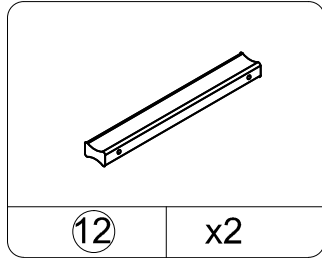
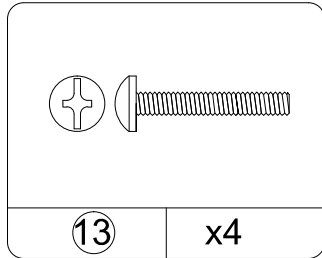
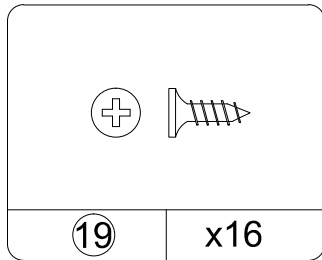
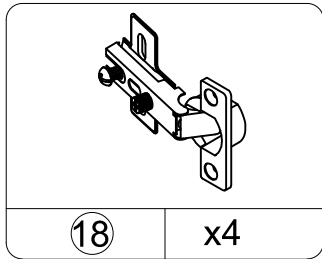

13

Adjust if doors are not aligned.
Ajustez si les portes ne sont pas alignées.

Adjust if there is a gap between doors.
Ajustez s'il y a un espace entre les portes.

Adjust if doors are too far from/close to the frame.
Ajustez si les portes sont trop éloignées ou trop près du cadre.

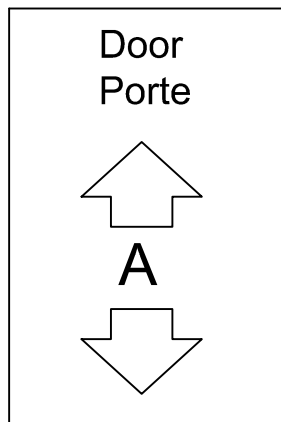

Front view
Vue de face

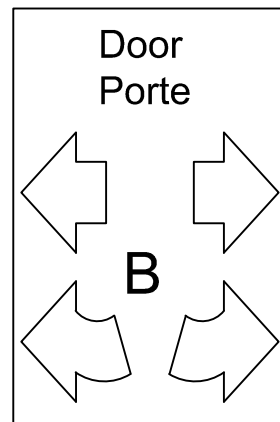

Front view
Vue de face

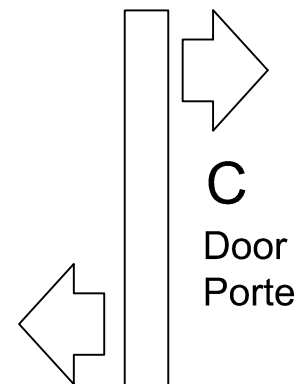

Side view
Vue latérale

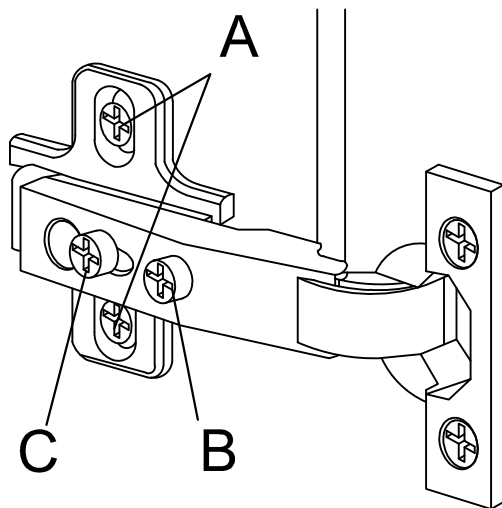

To adjust doors : "A"
Loosen "A" screws.
Adjust door.
Tighten "A" screws.

Pour ajuster les portes : "A"
Desserrez les vis "A".
Ajustez la porte.
Serrez les vis "A".

To adjust doors : "B"
Loosen "C" screw.
Turn "B" to move door.
Tighten "C" screws.

Pour ajuster les portes : "B"
Desserrez les vis "C".
Tournez "B" pour déplacer
la porte.
Serrez la vis "C".

To adjust doors : "C"
Loosen "C" screws.
Adjust door.
Tighten "C" screws.

Pour ajuster les portes : "C"
Desserrez les vis "C".
Ajustez la porte.
Serrez la vis "C".

14

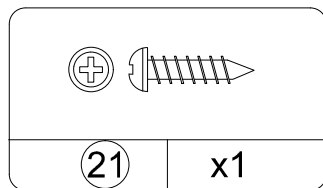
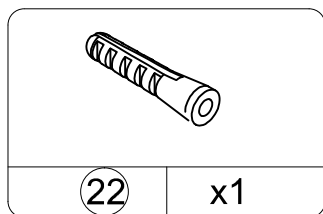
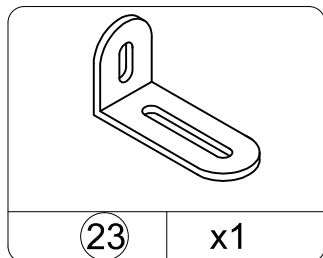
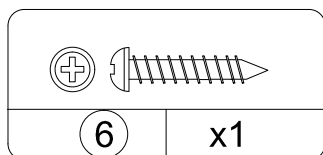
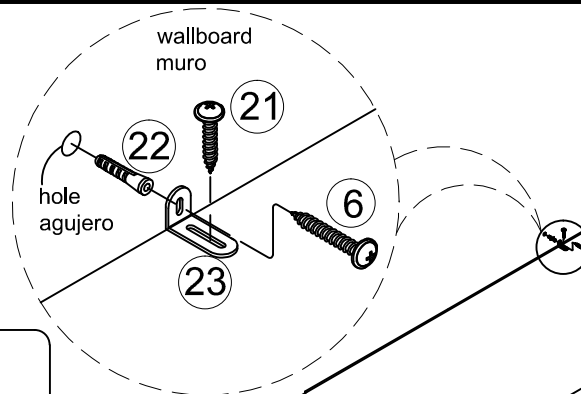

Drill a 5mm diameter hole (3/16") in the wallboard. Tap the wall anchor(13b) into the hole until it is flush.

Taradre un agujero de 5mm de diámetro (3/16") en la pared. Introduzca el soporte de pared (13b) hasta que el agujero quede plano.

▲ Warning
This unit must be anchored to a stud or wall, as shown. Failure to do so could cause severe injury.

▲ Atención
Esta unidad debe ser anclada contra un soporte o pared. No hacerlo, puede generar lesiones en los usuarios o daños en el mueble.

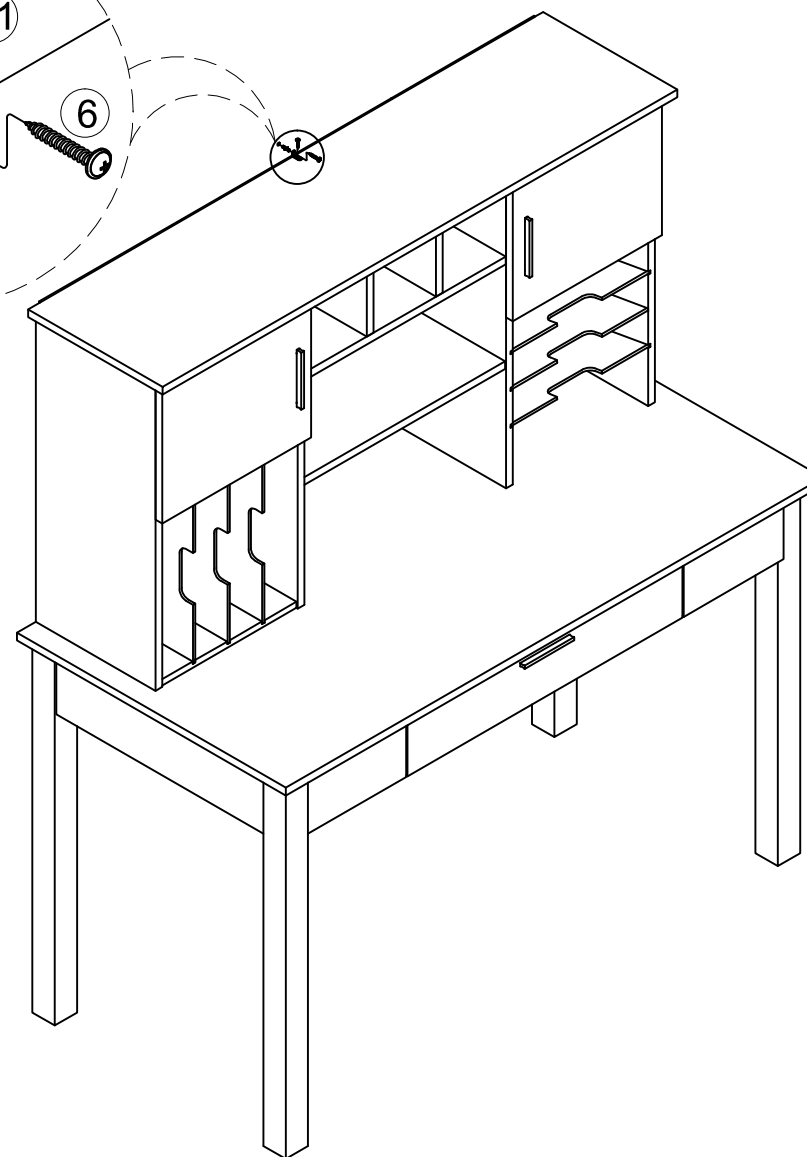

WEIGHT LIMITS:
LÍMITES DE PESO:

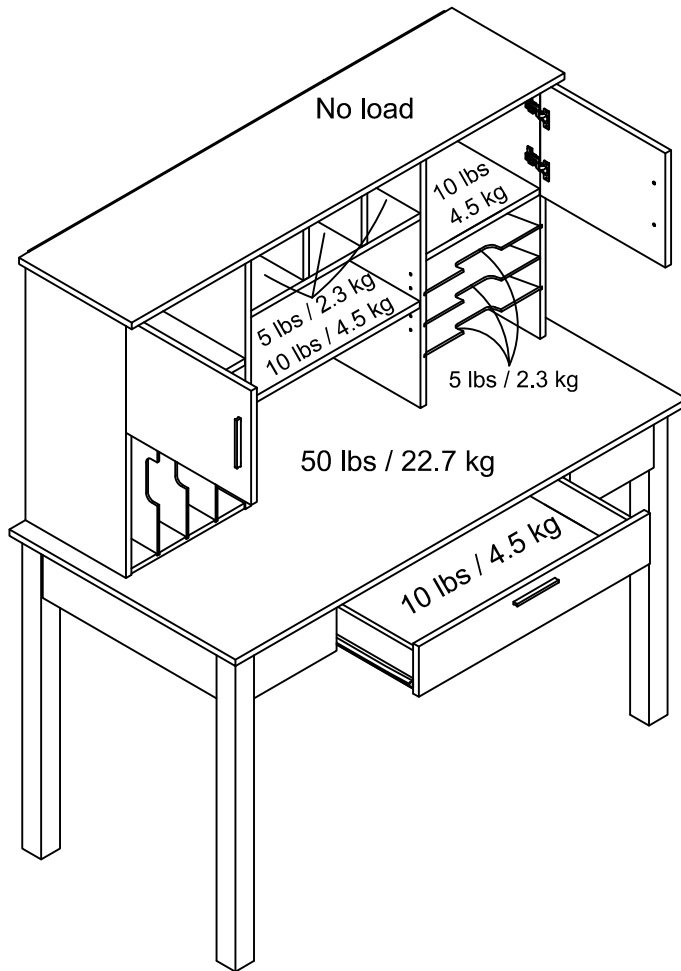

Enjoy Your Furniture
DISFRUTE DE SU MUEBLE

This unit has been designed to support the maximum loads shown.

Exceeding these load limits could cause sagging, instability, product collapse, and/or serious injury.

Esta unidad se ha diseñado para apoyar las cargas máximas mostradas.

Exceder estos límites de carga podría causar ceder, inestabilidad, derrumbamiento del producto, y/o lesión seria.

▲ WARNING

Please make sure that all objects are removed before moving the assembled unit.

The unit must be team lifted, not dragged or pushed. Failure to do so could cause instability, product collapse, and/or serious injury.

▲ ADVERTENCIA

Por favor mueva el mueble cuidadosamente con la ayuda de otra persona. Levante y mueva el mueble a su lugar. No lo arrastre o empuje, de lo contrario puede haber inestabilidad en el mueble y este puede colapsar u ocasionar graves lesiones.