

LEUCOS®

INSTRUCTIONS FOR INSTALLATION - LEUCOS USA

VITTORIA P2

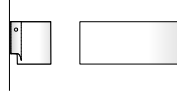

A1 Enclosed



One installer



Save instructions

Revised
26 / 07 / 2005

WARNING:

- DISCONNECT POWER BEFORE INSTALLATION.
- FIXTURE TO BE INSTALLED BY A CERTIFIED ELECTRICIAN.
- INSTALL IN ACCORDANCE WITH THE NATIONAL AND LOCAL ELECTRICAL CODES.
- TAKE GREAT CARE TO AVOID SCRATCHING OR CHIPPING THE GLASS WHEN, CARRYING OUT THE OPERATIONS BELOW

Fig.1 - Remove reflector "A" as shown and install structure "B" to the wall (Junction Octagonal Box - only for USA market) by the slots provided. Take care to install correctly as shown with the two holes "F" upward. **Fig.1**. Make the electrical connection to supply wire (guide excess wire inside J.Box.- for USA) **WARNING** : Cover the wire cables with the protections sheaths in equipment .Then replace reflector "A" .



Fig.2 - Inert bulb inside double ended socket, then place the two half safety glass pyrex tubes "Y" in order to be coupled inside the opposite collars of rings "X" as shown. Clamp the two parts by pushing the two release springs "Z" as shown in **Fig.2**.

Fig.3 - Install bracket "C" on the diffuser "D" by the two side threaded pins "E" provided as shown. Take care to tighten moderately only by fingers, do not use tools.

Fig.4 - Instal bracket "C", just assembled to the diffuser, to structure "B", by the two top holes and screws provided. Restore power.

WARNING : IF THE GLASS PROTECTIVE SLEEVE PYREX "Y" BREAKS , IT SHOULD BE REPLACED BEFORE USING THE LAMP AGAIN.

FOR USA MARKET ONLY:

VITTORIA P2 - max 1x150W 120V T3 RSC (SHORT) 
 max 2x9W 120V G23 Twin Tube 

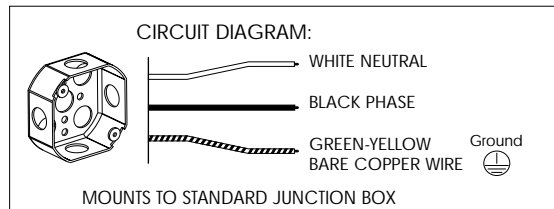

For additional information please contact your local dealer or **LEUCOS U.S.A.** At: Tel. (732) 225-0010 Fax. (732) 225-0250

Fig.1

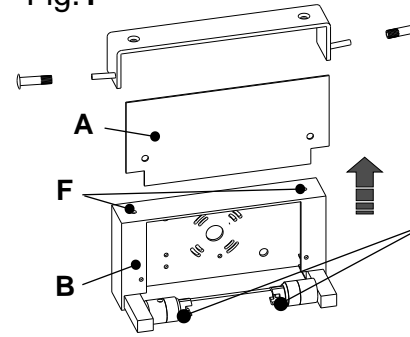

Fig.2

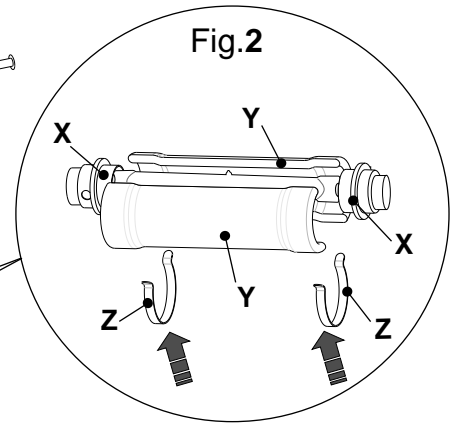

Fig.3

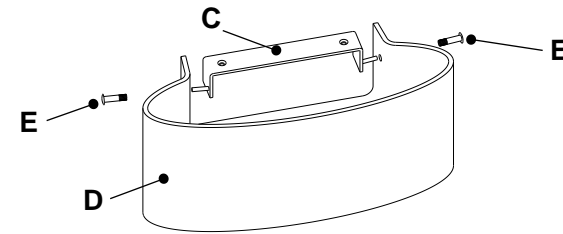
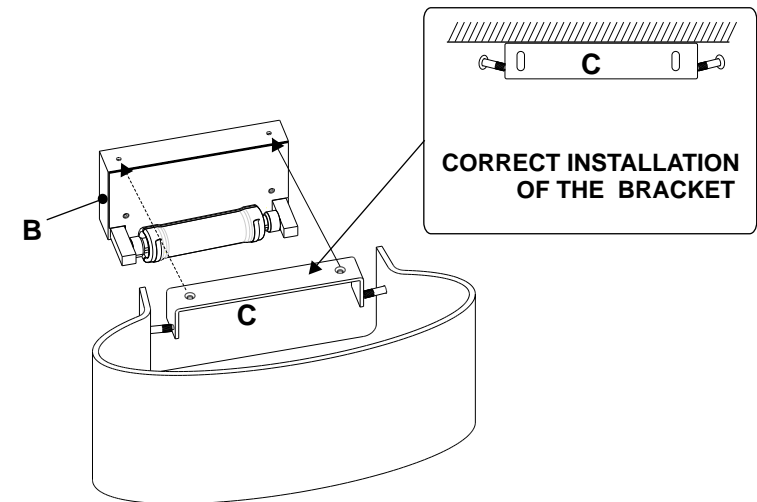

Fig.4



LEUCOS®

ASSEMBLING INSTRUCTIONS FOR LAMP CONTAINMENT BARRIER ON THE FIXTURES PROVIDEING R7s DOUBLE CONTACT HALOGEN LAMPS ANDFOR ANTI-GLARE SCREEN ON MODELS VITTORIA

A1

Enclosed



One installer



Save instructions

Revised
15 -05 - 2003

1. Insert bulb inside double ended socket, then place the two half safety glass pyrex tubes "Y" in order to be coupled inside the opposite collars of rings "X" as shown. Clamp the two parts by pushing the two release springs "Z" as shown in **Fig.1**.
2. Push down the Anti-glare screen "K", by the two side springs, on the outside collars of the two side rings "X" **Fig.2**.

WARNING: IF THE GLASS PROTECTIVE SLEEVE PYREX "Y" BREAKS, IT SHOULD BE REPLACED BEFORE USING THE LAMP AGAIN.

Fig. 1

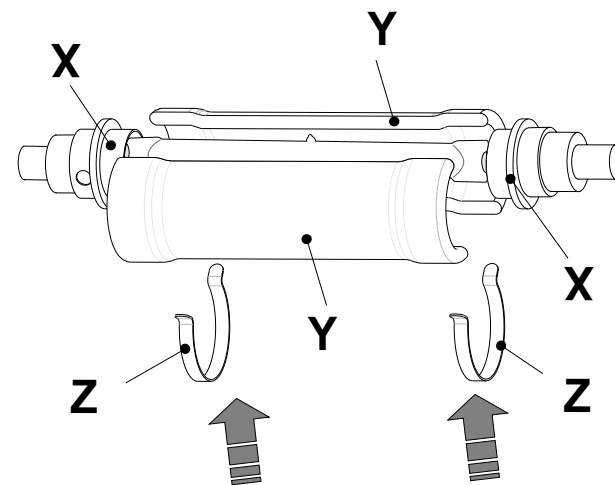

Fig. 2

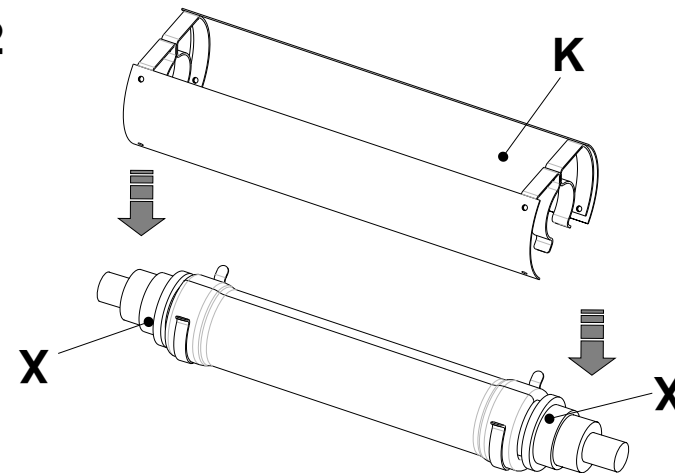

Fig. 3

