



ASSEMBLY INSTRUCTIONS

Read this instruction carefully. See hardware and furniture part list for guidance. Be sure all part is complete, before you assemble. Place all wooden furniture part on a clean and flat soft surface to prevent from being scratched. Follow the figure to start assembling.

CAUTIONS :

1. Do not FULLY-TIGHTEN the nut or nut bolt until all nut or bolt is ready assembled.
2. Do not OVER-TIGHTEN the nut or nut bolt to avoid causing damages to the thread.
3. Keep all hardware part out of reach of children.

HARDWARE LIST

ITEM	DESCRIPTION	QTY
1	JCBC M6 x 60mm 	8 PCS
2	JCBC M6 x 35mm 	30 PCS
3	Barrer Nut M6 x 15mm 	8 PCS
4	Flat Washer M6 	38 PCS

HARDWARE LIST

ITEM	DESCRIPTION	QTY
5	Wood Dowel M8 x 25mm 	12 PCS
6	Wood Dowel M10 x 30mm 	4 PCS
7	CSK Screw M4 x 32mm 	20 PCS
8	M4 L Key 	1 PC

Step 1:

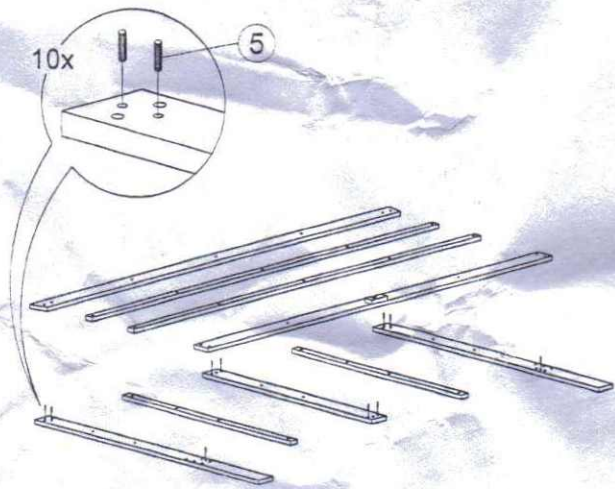

Step 2:

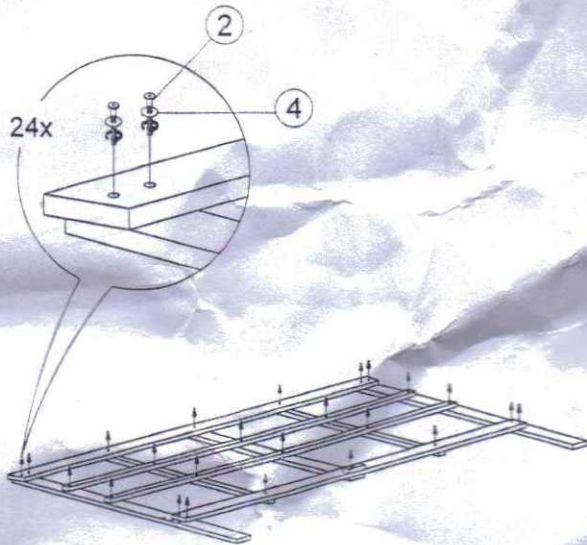

Step 3:

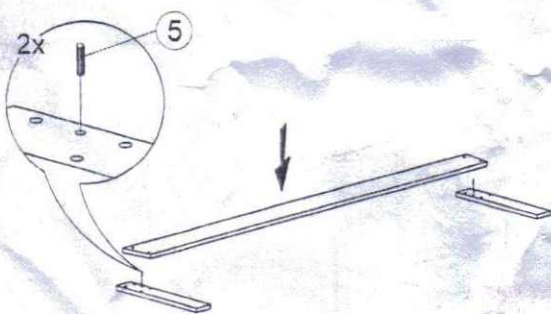

Step 4:

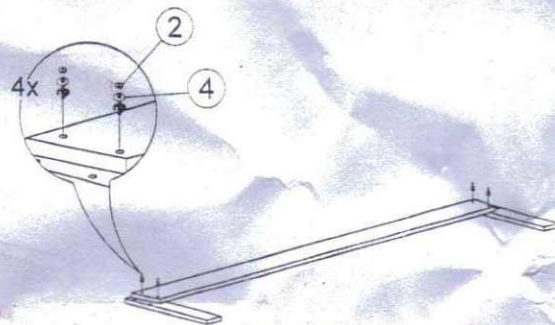

Step 5:

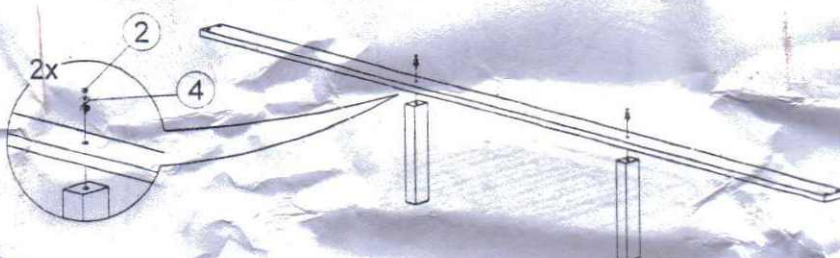

ASSEMBLY INSTRUCTIONS

Read this instruction carefully. See hardware and furniture part list for guidance. Be sure all part is complete, before you assemble. Place all wooden furniture part on a clean and flat soft surface to prevent from being scratched. Follow the figure to start assembling.

CAUTIONS :

1. Do not FULLY-TIGHTEN the nut or nut bolt until all nut or bolt is ready assembled.
2. Do not OVER-TIGHTEN the nut or nut bolt to avoid causing damages to the thread.
3. Keep all hardware part out of reach of children.

HARDWARE LIST		
ITEM	DESCRIPTION	QTY
1	JCBC M6 x 60mm 	8 PCS
2	JCBC M6 x 35mm 	30 PCS
3	Barrel Nut M6 x 15mm 	8 PCS
4	Flat Washer M6 	38 PCS

HARDWARE LIST		
ITEM	DESCRIPTION	QTY
5	Wood Dowel M8 x 25mm 	12 PCS
6	Wood Dowel M10 x 30mm 	4 PCS
7	CSK Screw M4 x 32mm 	20 PCS
8	M4 L Key 	1 PC

Step 6:

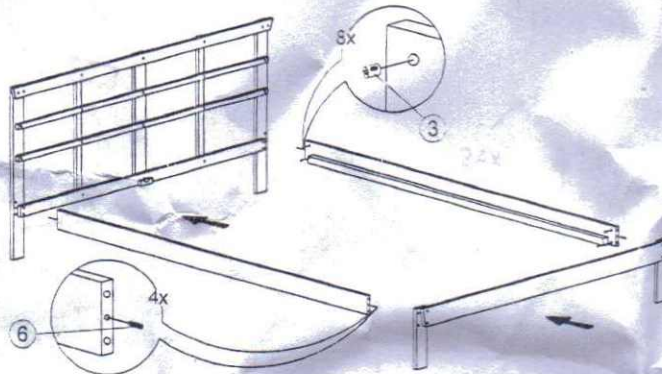

Step 7:

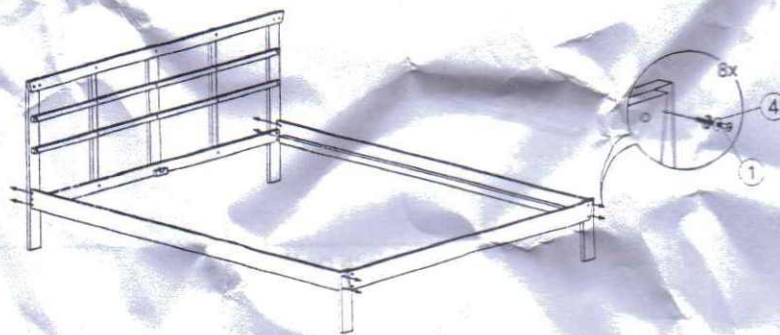

Step 8:

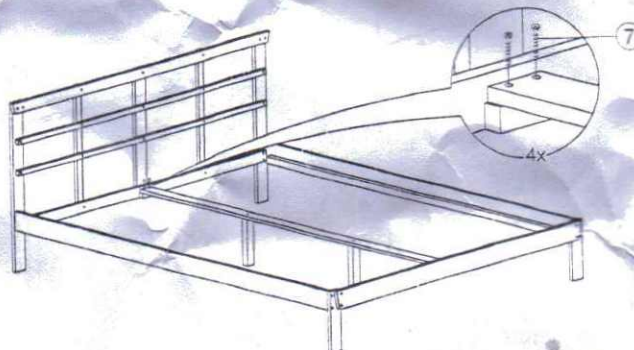

Step 8:

