

# Model 195 Ergonomic Management Chair

## Parts Listing

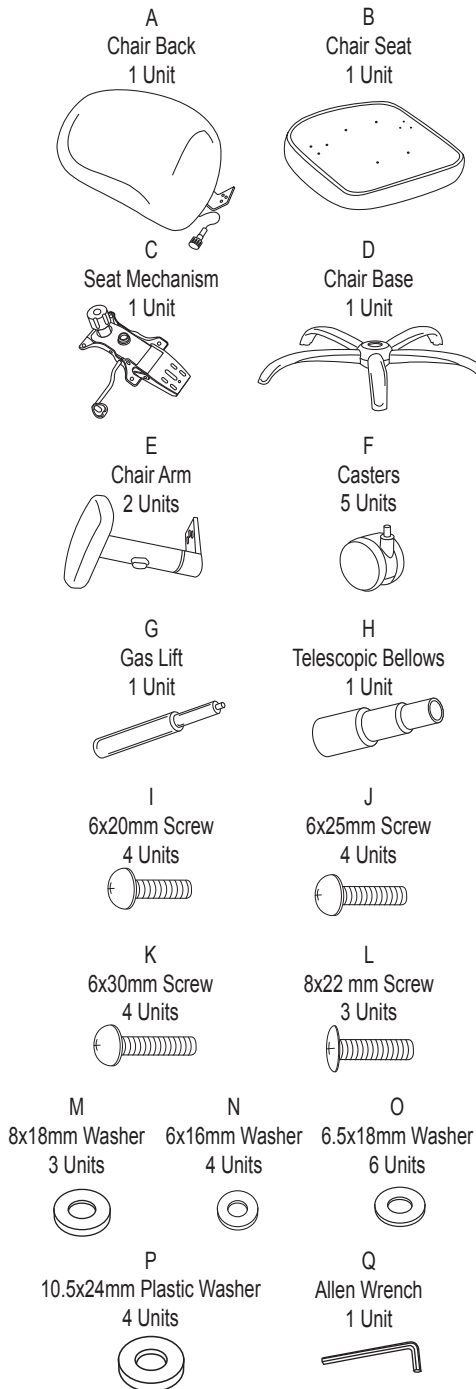

## Assembly Instructions

**Tools Needed: Phillips Head Screwdriver**  
*Please read all instructions before assembly.*

- Step 1:** Insert Casters (F) into 5-star Chair Base (D).
- Step 2:** Insert Gas Lift (G) into Chair Base (D), and cover with Telescopic Bellows (H).
- Step 3:** Attach Seat Mechanism (C) to bottom of Chair Seat (B) using 6x20mm Screw (I) and 6x16mm Washer (N). Tighten using Allen Wrench (Q).
- Step 4:** Attach Chair Back (A) to Chair Seat (B) using 8x22mm Screws (L) and 8x18mm Washer (M). Tighten using Allen Wrench (Q). Attach lumbar knob on Chair Back (A) to bottom of Chair Seat (B) using 6x25mm Screw (J).
- Step 5:** Attach Chair Arms (E) to bottom of Chair Seat (B) by placing 10.5x24mm Plastic Washer (P) between the Chair Seat and the Chair Arms (Two on each side under the holes closest to the side of the chair). Then insert 6x30mm Screws (K) through 6.5x18mm Washers (O) and into the holes on the Chair Arm (E). Tighten using Allen Wrench (Q).
- Step 6:** Place Chair Seat (B) onto top of Gas Lift (G) and press down firmly on chair to secure.

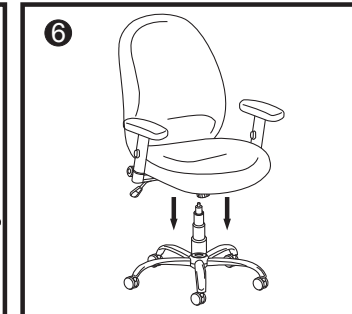
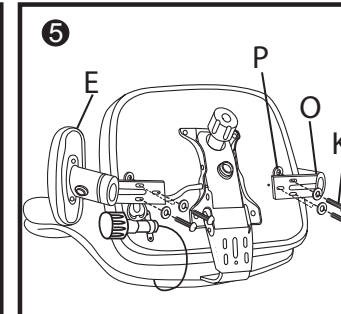
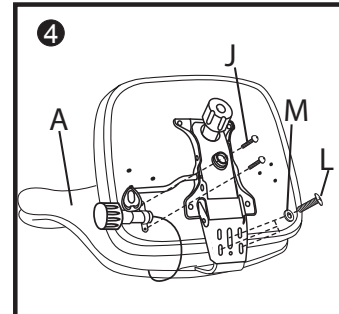
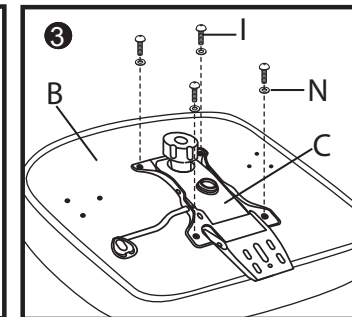
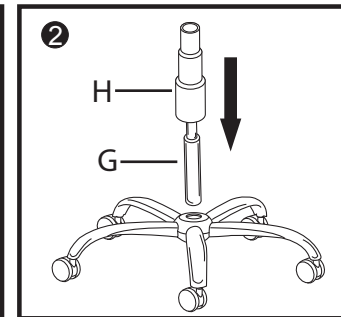
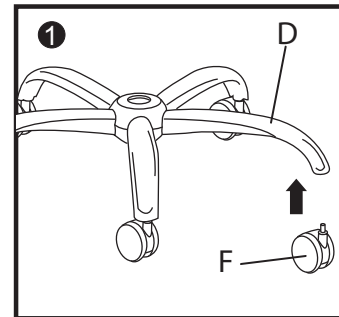

**WEIGHT CAPACITY: 250 lbs.**

### Assembly Notes:

During assembly, hand tighten screw only when all screws are in place, you may then tighten all screws completely.

### CAUTION:

1. Do not use this chair as a step ladder.
2. Check for loose screws and tighten them every 6 months.

**ofm**  
Furniture For The Real Office™

161 Tradition Trail Holly Springs, NC, 27540  
800-520-7471 (voice) 919-362-4765 (fax)  
919- 303-6389 (voice) www.ofmnc.com  
support@ofmnc.com