

Model 2016 Profile Lamp Table

Parts Listing

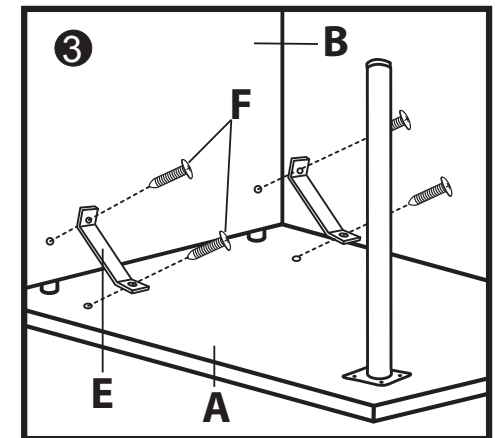
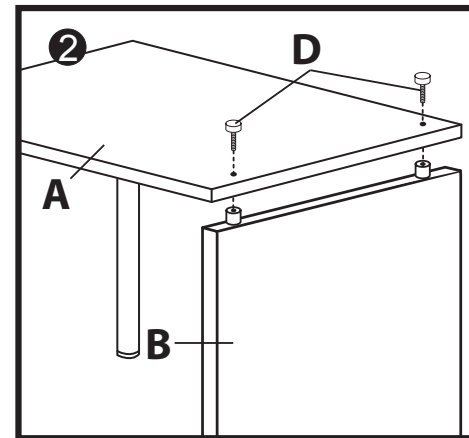
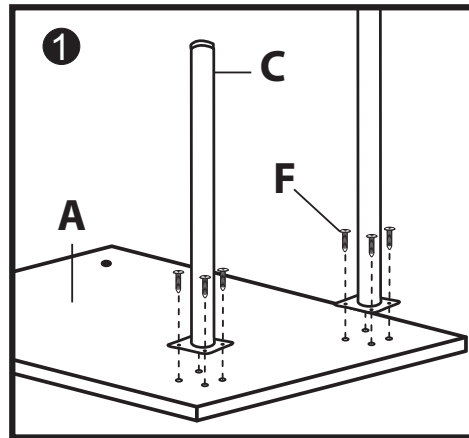
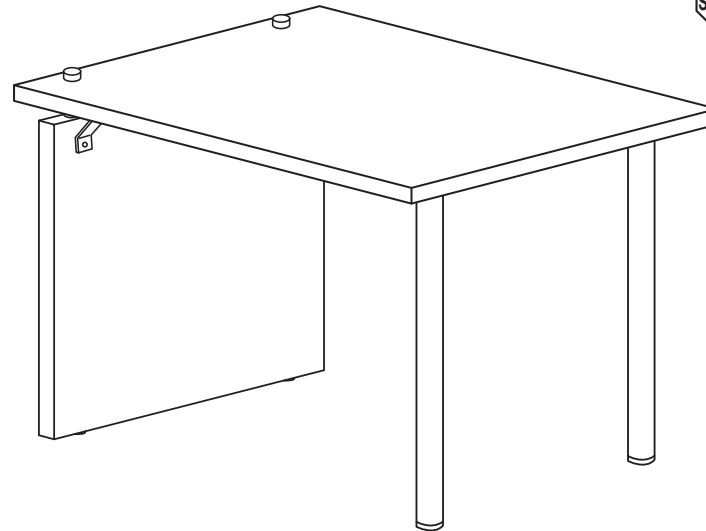
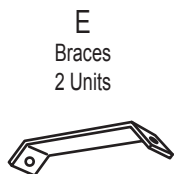
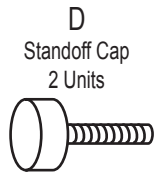
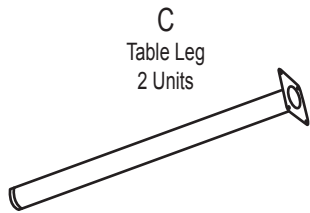
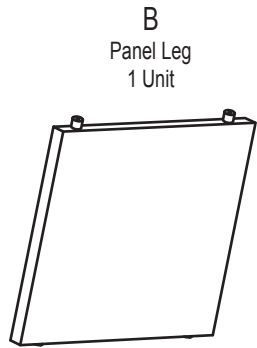
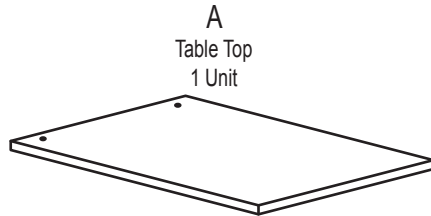

WEIGHT CAPACITY: 40 lbs.

Assembly Notes:

During assembly, hand tighten screws only. When all screws are in place, you may then tighten all screws completely.

CAUTION:

1. Do not use this table as a step ladder.
2. Check for loose screws and tighten them every 6 months.

Assembly Instructions



Tools Needed: Phillips Head Screwdriver
Please read all instructions before assembly.

Step 1: Place the Table Top (A) upside down on a clean, flat surface. Attach Table Legs (C) to Table Top (A) by inserting Screws (F) through holes in baseplate and into the holes at the front of the Table Top (A). Tighten with screwdriver.

Step 2: Turn Table Top (A) over so that the pattern is facing up. Attach Panel Leg (B) to Table Top (A) by aligning holes in the Table Top (A) with holes in the metal spacers on the top of the Panel Leg (B). Insert Standoff Caps (D) through Table Top (A) and into holes in Panel Leg (B). Tighten by placing small allen wrench in the exterior hole on the side of the Standoff Caps (D). Turn the allen wrench so that the Standoff Cap (D) is rotated clockwise.

Step 3: Turn table over and place on a clean, flat surface. Secure the Panel Leg (B) to the Table Top (A) by attaching the Brace (E) with Screws (F). Tighten with screwdriver.

ofm
Furniture For The Real Office™

161 Tradition Trail Holly Springs, NC, 27540
800-520-7471 (voice) 919-362-4765 (fax)
919-303-6389 (voice) www.ofminc.com
support@ofminc.com