

Model 408-C Café Height Chair

Parts Listing

A
6x45mm Screws
4 Units



B
6x20mm Screws
4 Units



C
Frame Screws
2 Units

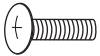

D
Washer
8 Units



E
Plastic Screw Cap
2 Units



F
Allen Wrench
1 Unit



G
Chair Back
1 Unit

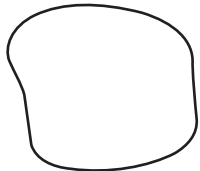

H
Chair Seat
1 Unit

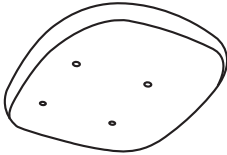

I
Chair Frame Sides
2 Units

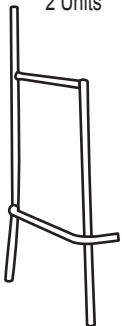

J
Chair Seat Crossbars
2 Units



K
Chair Frame Crossbar
1 Unit

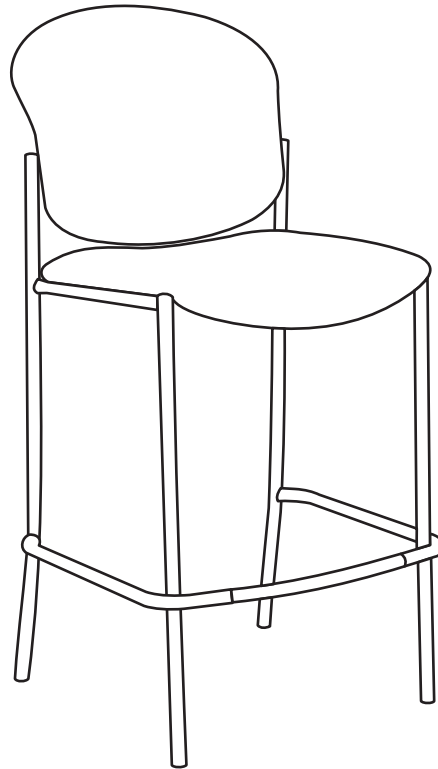

Assembly Instructions



Tools Needed: Phillips Head Screwdriver
Please read all instructions before assembly.

- Step 1:** Attach Seat Crossbars (J) to Left and Right Sides (I), making sure that the pre-drilled holes in braces align with the holes in frame.
- Step 2:** Connect Frame Crossbar (K) to Chair Frame (I) with Frame Screws (C) using a screwdriver.
- Step 3:** Attach Chair Seat (H) to the Chair Frame (I) by placing four Washers (D) onto four 6x45mm Screws (A), and inserting them through the Seat Crossbars (J) and into the Chair Seat (H).
- Step 4:** Attach Chair Back (G) to the Chair Frame (I) by placing four Washers (D) onto four 6x20mm Screws (B), and inserting them through metal plates on the Chair Frame (I) and into the Chair Back (G).
- Step 5:** Tighten all screws on Chair Seat (H) and Chair Back (G) with screwdriver.
- Step 6:** Place Plastic Screw Cap (E) over the 6x20mm Screws (B) by sliding cover over the plate on the Chair Frame (I) and snap into place.

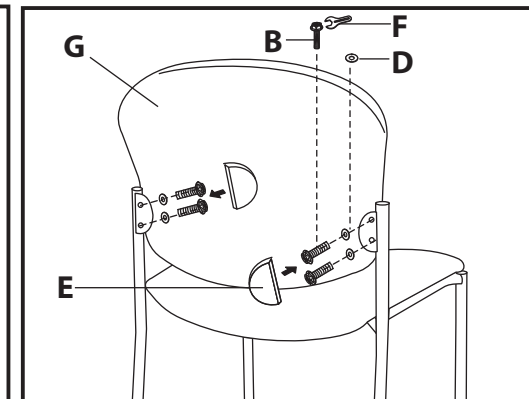
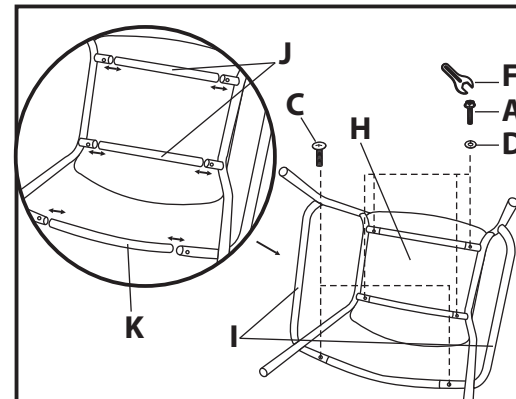

WEIGHT CAPACITY: 250 lbs.

Assembly Notes:

During assembly, hand tighten screw only when all screws are in place, you may then tighten all screws completely.

CAUTION:

1. Do not use this chair as a step ladder.
2. Check for loose screws and tighten them every 6 months.

ofm
Furniture For The Real Office™

161 Tradition Trail Holly Springs, NC, 27540
800-520-7471 (voice) 919-362-4765 (fax)
919-303-6389 (voice) www.ofminc.com
support@ofminc.com