

Model 66510 Mesa Series Training Table

Parts Listing

A
Table Top
1 Unit

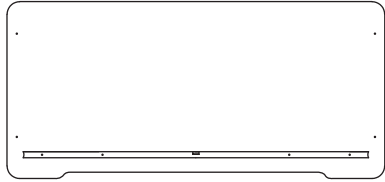

B
Side Panel Legs
2 Units

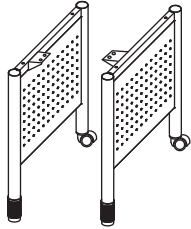

C
Privacy Panel
1 Unit

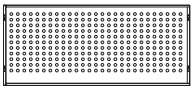

D
Corner Leg Bracket
2 Units

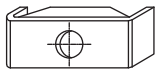

E
10x35mm Screw
2 Units



F
6x16mm Screw
4 Units



G
5x10mm Screw
4 Units



H
Allen Wrench
1 Unit



I
Phillips Head Screw Bit
1 Unit

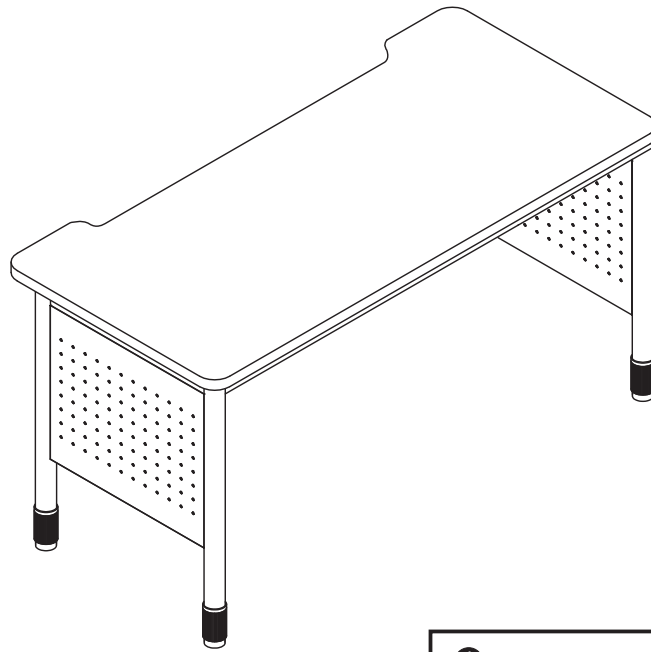
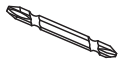

Assembly Instructions



Tools Needed: Phillips Head Screwdriver
Please read all instructions before assembly.
Assembly will require 2 people.

Step 1: Align Side Panel Legs (B) with the support rail on the underside of the Table Top (A). Place Corner Leg Bracket (D) in holes on support rail, and insert 10x35mm Screw (E) through bracket and into legs. Tighten using Allen Wrench (H). Align holes on Side Panel Leg bracket with holes on the underside of the Table Top (A). Insert 6x16mm Screws (F) through bracket and into top, and secure using Phillips Head Screw Bit (I).

Step 2: Attach Privacy Panel (C) to Side Panel Legs (B) by inserting 5x10mm Screws (G) through sides of Privacy Panel (C) and into side of Side Panel Legs (B).

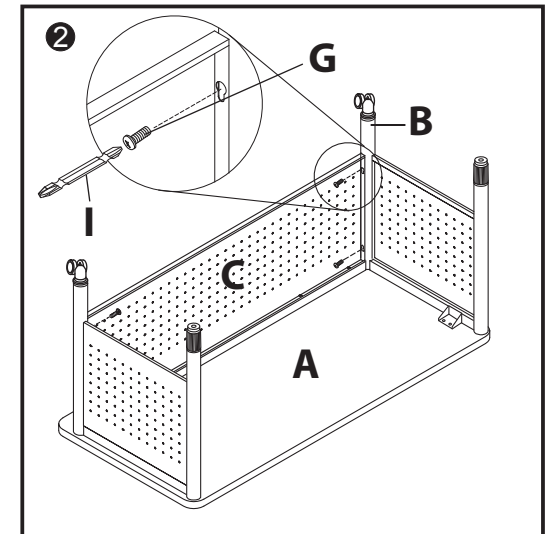
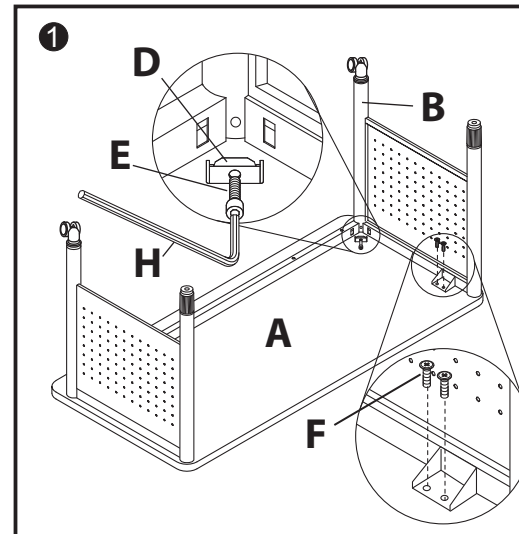

Assembly Notes:

During assembly, hand tighten screws only. When all screws are in place, you may then tighten all screws completely.

CAUTION:

1. Do not use this table as a step ladder.
2. Check for loose screws and tighten them every 6 months.

ofm
Furniture For The Real Office™

161 Tradition Trail Holly Springs, NC, 27540
800-520-7471 (voice) 919-362-4765 (fax)
919-303-6389 (voice) www.ofminc.com
support@ofminc.com