

Model 654 Vision Executive Chair

Parts Listing

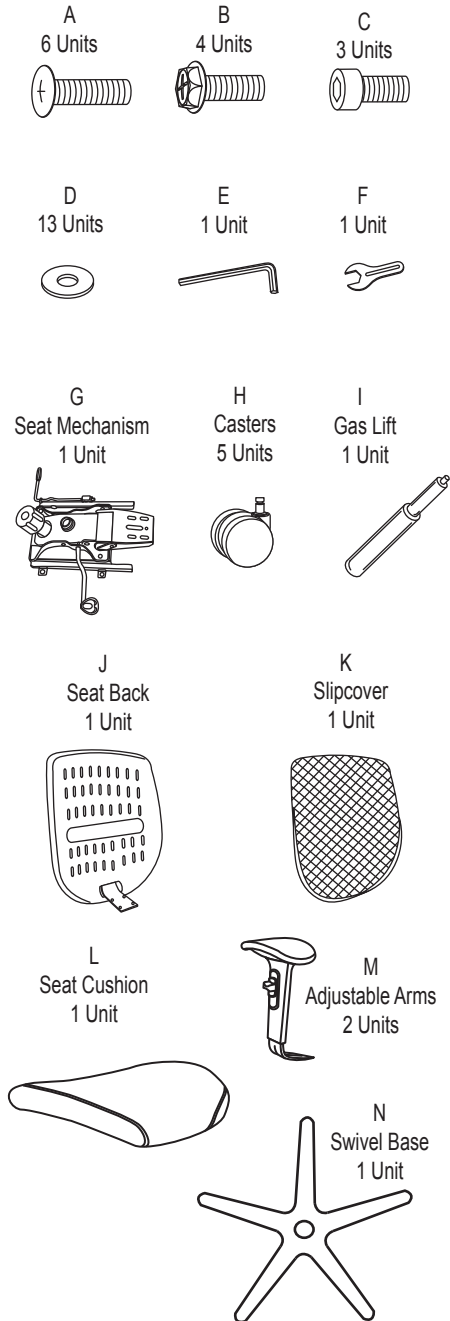

Assembly Instructions

Tools Needed: Phillips Head Screwdriver
 Please read all instructions before assembly.

- Step 1:** Insert Casters (H) into Swivel Base. Insert Gas Lift (I) into Swivel Base (N).
- Step 2:** Attach Adjustable Arms (M) to Seat Cushion (L) using screws (A) and washers (D). Tighten screws with phillips head screwdriver.
- Step 3:** Cover plastic Seat Back (J) with replaceable Slipcover (K), and place mount plate through slipcover before securely zipping.
- Step 4:** Attach Seat Mechanism (G) to the Seat Cushion (L) with 4 Bolts (B) and washers (D), using the Wrench (F) that is provided.
- Step 5:** Insert mounting plate on Seat Back (J) into Seat Mechanism (G) and attach with 3 Screws (C), using Allen Wrench (E) that is provided.
- Step 6:** Take entire chair frame and place Seat Mechanism (G) onto Gas Lift (I), and press down firmly to secure.

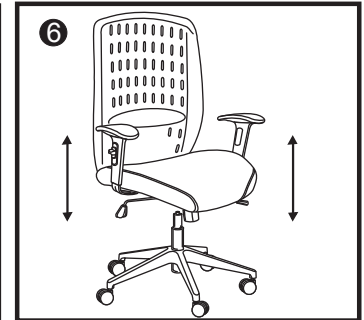
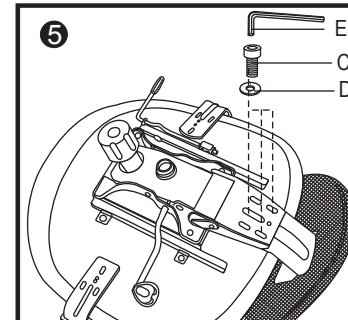
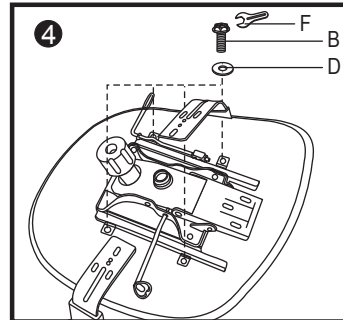
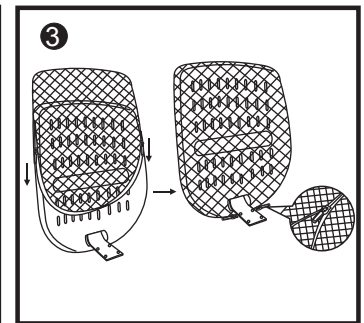
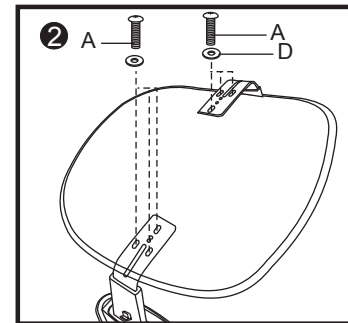
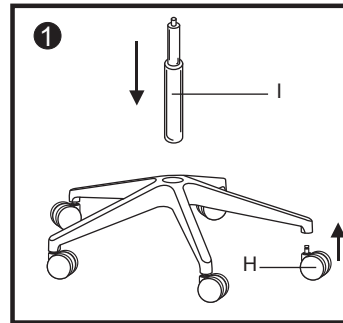

WEIGHT CAPACITY: 250 lbs.

Assembly Notes:

During assembly, hand tighten screw only when all screws are in place, you may then tighten all screws completely.

CAUTION:

1. Do not use this chair as a step ladder.
2. Check for loose screws and tighten them every 6 months.



161 Tradition Trail Holly Springs, NC, 27540
 800-520-7471 (voice) 919-362-4765 (fax)
 919-303-6389 (voice) www.ofminc.com
 support@ofminc.com