

IN00430 (rev A)

Aqua 8 Glide Quadrant and Off-set Quadrant Enclosure

AQUA 8

DESIGNED AROUND YOU

- Instruction suitable for both Quadrant & Off-set Quadrant variations.
- Instruction suitable for both Right and Left Hand fixing variations on Off-set Quadrants.

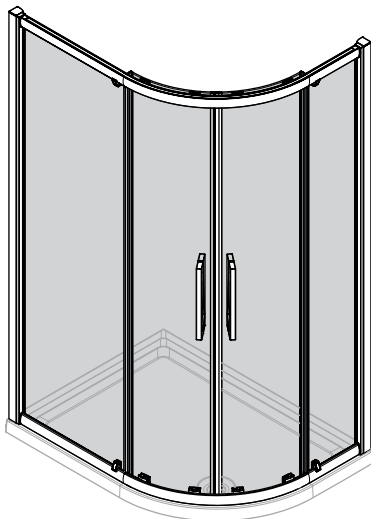
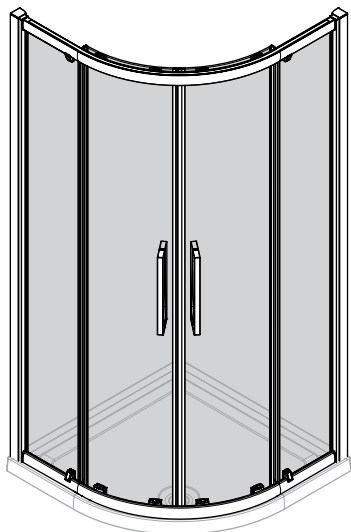

Before You Start

- Check that the tray has been installed correctly and that it is level (Fig. A), tiled down onto and sealed to the manufacturer's guidelines. **Please Note:** All product supplied without tray.
- Ensure the product is fitted to a non-porous surface ie. tiled. Check that the wall surface is flat.
- Unpack and check the product is complete and undamaged.
- Fixings are supplied for solid walls only. Ensure that the correct fixings are used for the wall type – if in doubt seek professional advice.
- Ensure the area is clean, dry and dust free.
- Read the instructions in full.
- Have the correct tools available, (as shown below, see 'Tools Required').
- It is recommended to situate the showerhead and door adjacent to each other in order to allow any water spray to be on the side panel or upstanding wall.

Fig.A.

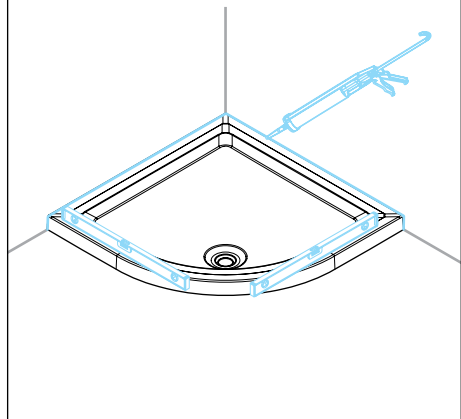

Safety

- Handle all glass with care - support on cardboard to avoid risk of breakage.
- This product is heavy and requires 2 people to carry and install it.
- When drilling walls check first for hidden pipes and cables.
- All glass is toughened – it cannot be reworked or replaced by ordinary glass.
- Use safety eyewear when drilling.
- Use safety eyewear when handling glass.
- Keep all small parts away from children.

Disclaimer

- Please notify the retailer immediately of any damage or faults. The manufacturer cannot be held responsible for any installation costs that may arise from damaged or faulty product being installed.
- Please dispose of all packaging with due regard to the environment.

Tools Required (not supplied)

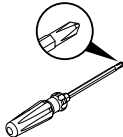
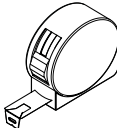
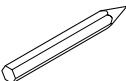
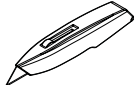
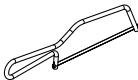
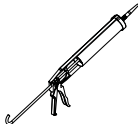
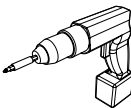
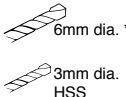
<p>Spirit Level</p> 	<p>Screwdriver</p> 	<p>Tape Measure</p> 	<p>Pencil</p> 	<p>Utility Knife</p> 
<p>Junior Hacksaw</p> 	<p>Silicone Gun & Sealant</p> 	<p>Power Drill</p> 	<p>Suitable Drill Bits</p>  <p>6mm dia. *</p> <p>3mm dia. HSS</p>	<p>* Ensure drill bit used is suitable for wall surface</p>



Help Line: 0870 241 6131

Lines open: 8.30am - 5.00pm Monday to Friday
Standard National call charge rate from BT landlines

Parts & Fittings Supplied



Please notify the retailer immediately of any damage or faults. The manufacturer cannot be held responsible for any installation costs that may arise from a damaged or faulty product being installed.



Keep small parts away from children

***Off-set Quadrant Variant:**
Glass Panel supplied one long , one short

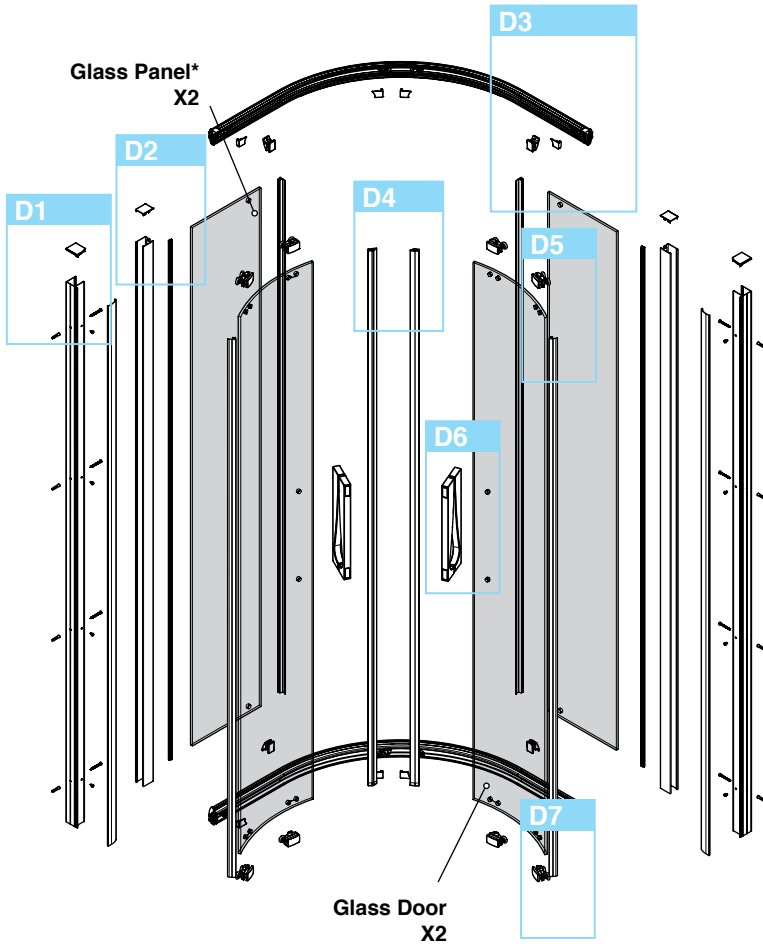

Allen Keys Supplied



3mm Allen Key

D1

*Left and right hand variants supplied

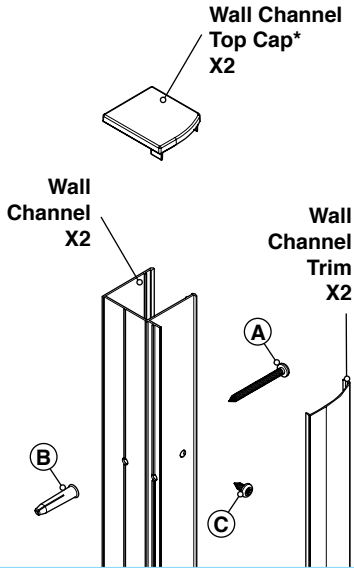

D2

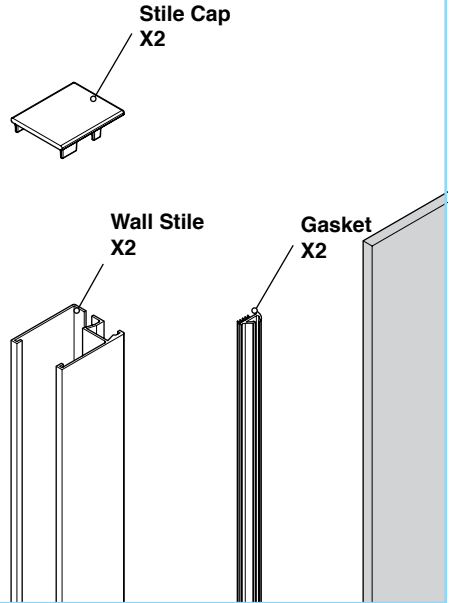

D3

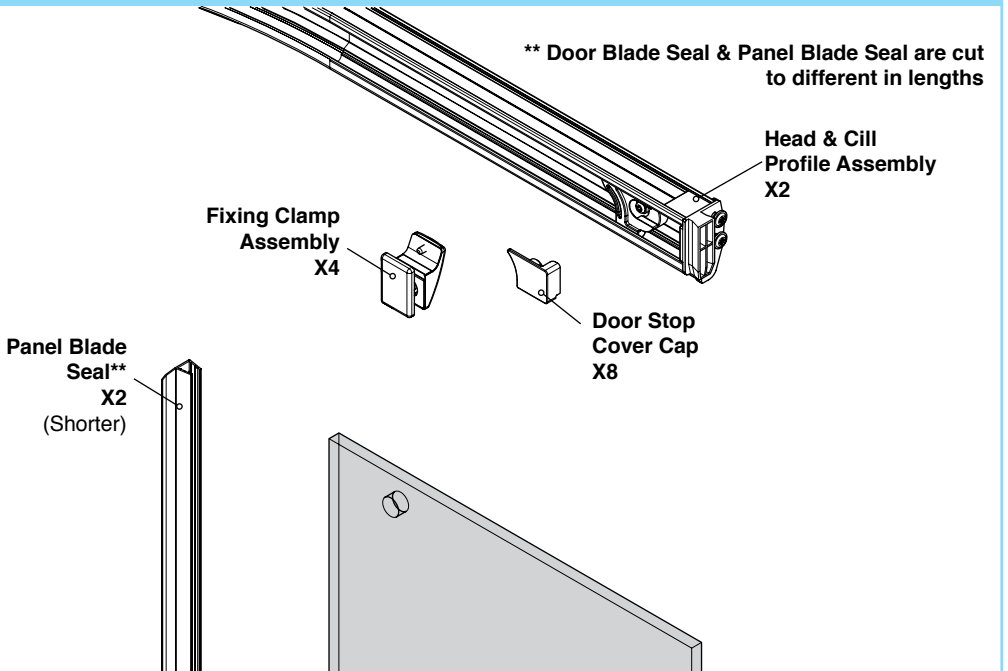

D4

Magnet Seal
X2

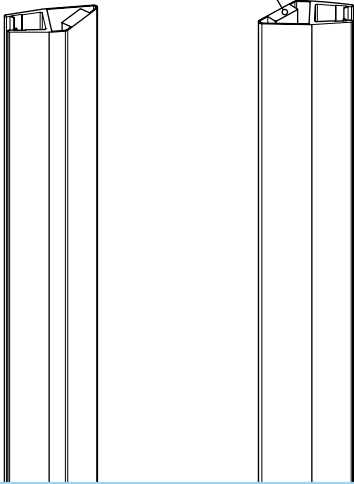

D5

** Door Blade Seal & Panel Blade Seal
are cut to different in lengths

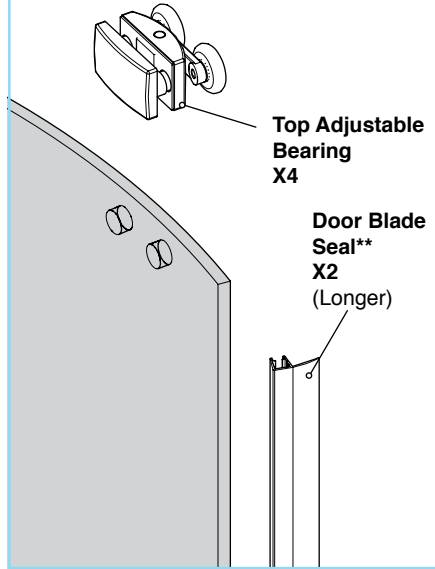

Top Adjustable
Bearing
X4

Door Blade Seal**
X2
(Longer)

D6

Door Handle
X2

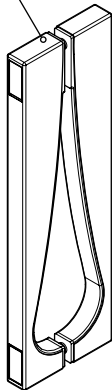

D7

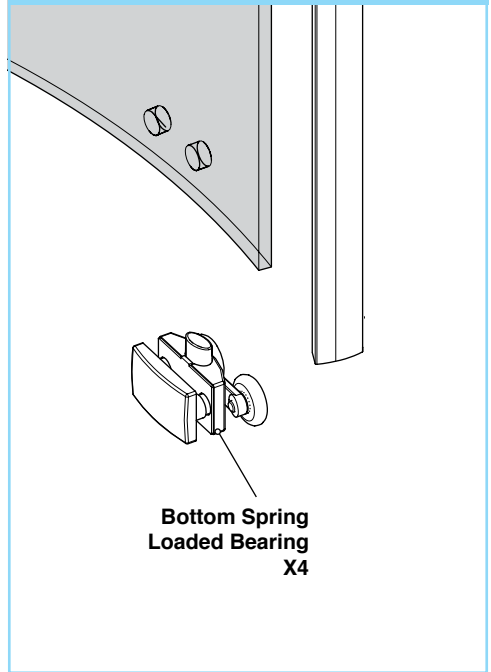

Bottom Spring
Loaded Bearing
X4

Loose Screws & Fittings Supplied

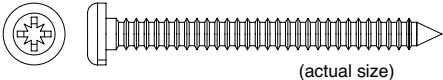
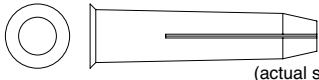
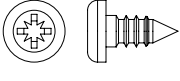
(A)	No.8 x 1 3/4" Pan Head Pozi Screws	 <p>(actual size)</p>	Qty x8
(B)	Wall Plugs	 <p>(actual size)</p>	Qty x8
(C)	No.8 x 3/8" Pan Head Pozi Screws	 <p>(actual size)</p>	Qty x8

Inside View

1

Slide Stile into position on Cill Assembly Profile as shown*

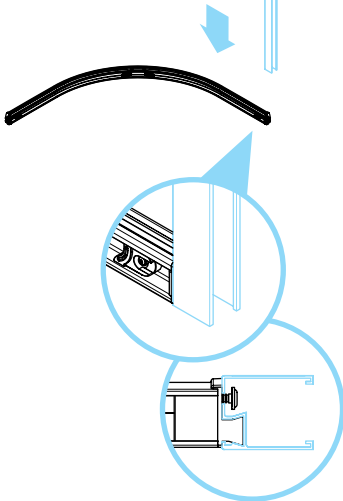
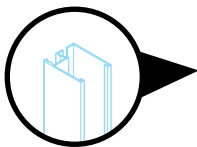

IMPORTANT NOTE:

Ensure that this assembly (1-10) is carried out on a flat / level surface.



Ensure correct Closing Stile and Cill Assembly orientation.

*Closing Stile/ Side Stile location detail Inside View:

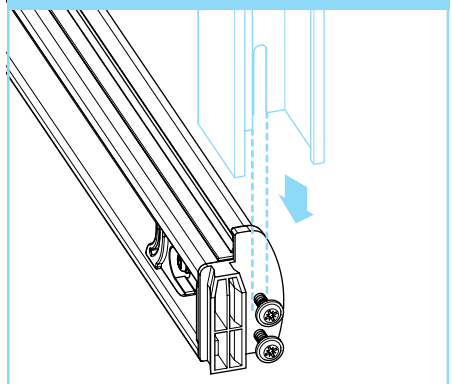

Inside View

2

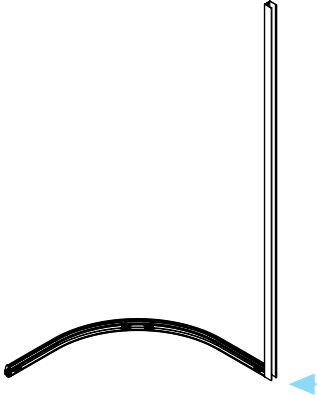

IMPORTANT NOTE:

Ensure product is assembled on a level surface/ floor and that the frame assembly is straight and level.

Inside View

i)

Pre-fitted Cill Assembly screws.

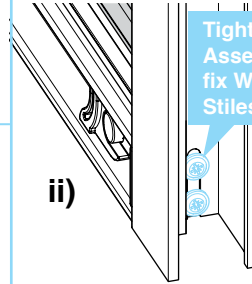

ii)

Tighten pre-fitted Cill Assembly screws to fix Wall & Closing Stiles.

Inside View

3.1

Inside View, Alternative Angle

i)

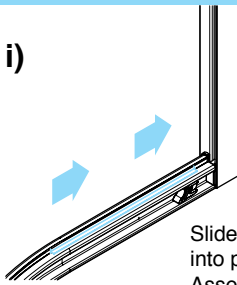

Slide pre-fitted seal into position on Cill Assembly as shown

ii)

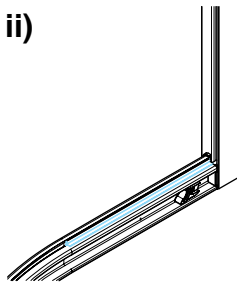

For Off-set Quadrant Installations, please fit large glass panel at this stage.

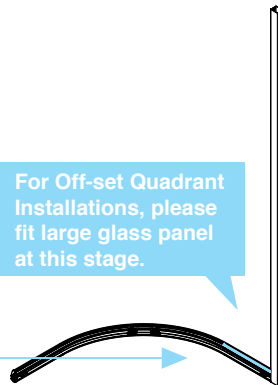

Ensure pre-fitted seal on Cill Profile Assembly is pushed up against Wall Stile.

3.2

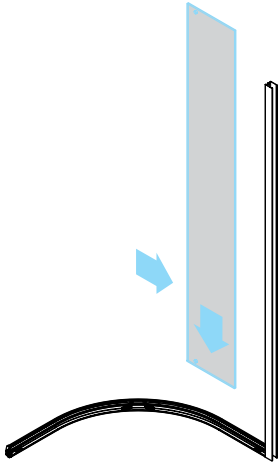

! Please take care when handling glass.

! Locate Glass Front Panel into Stile.

Inside View

4

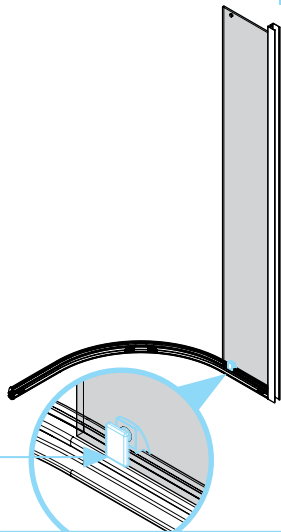
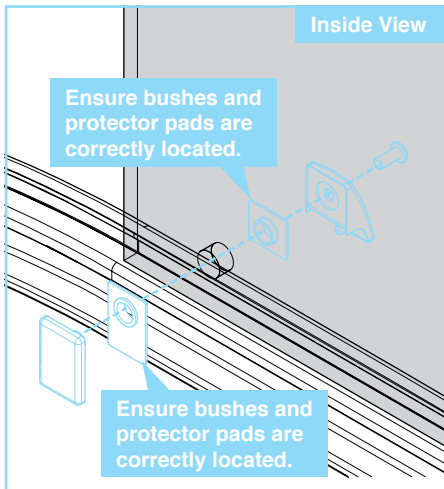

! Please Note: Fixing Brackets are supplied assembled. Using Allen key supplied, disassemble part and then re-assemble as shown. DO NOT overtighten.

! DO NOT fit cover cap at this stage. Screw heads are on OUTSIDE of the enclosure.

5

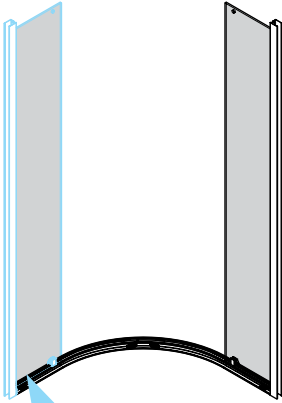

Once you have assembled one Front Glass Panel assemble opposite Front Glass Panel as detailed in steps 1-4.



IMPORTANT NOTE:

Ensure product is assembled on a level surface/ floor and that the frame assembly is straight and level.

6

Inside, Underside View

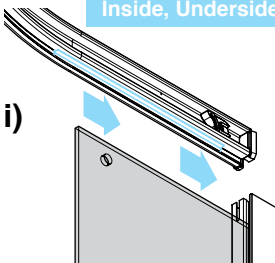

Slide pre-fitted seal into position on Head Assembly as shown

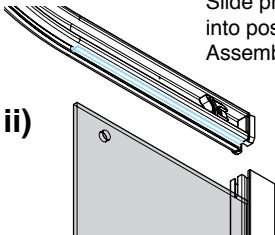

Ensure pre-fitted seal on Head Profile Assembly is pushed up against Stile prior to slotting Head Profile Assembly into position.

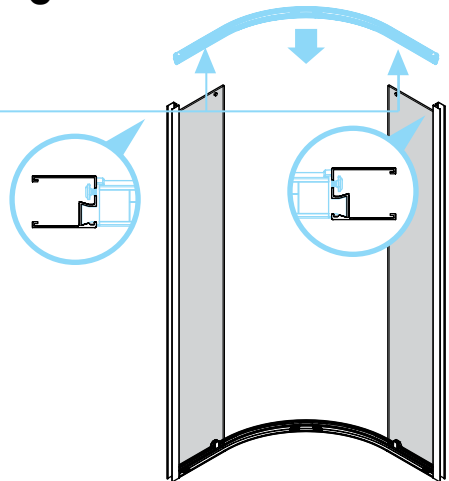

Ensure that the Head Profile Assembly is push right down on top of glass panels.

7

Inside View

Ensure bushes and protector pads are correctly located.

Ensure bushes and protector pads are correctly located.

! Please Note: Fixing Brackets are supplied assembled. Using Allen key supplied, disassemble part and then re-assemble as shown. DO NOT overtighten.

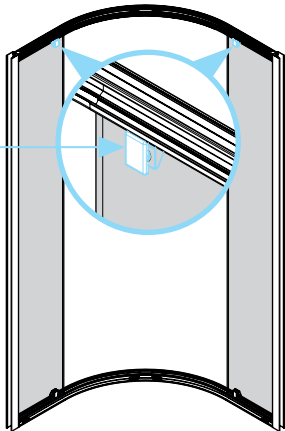

! DO NOT fit cover cap at this stage. Screw heads are on OUTSIDE of the enclosure.

Inside View

8

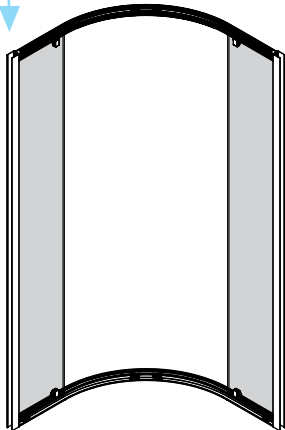

! IMPORTANT NOTE: Ensure that Head Assembly is located on top of glass prior to tightening pre-fitted screws.

Inside View

Pre-fitted Cill Assembly screws.

i)

Tighten pre-fitted Cill Assembly screws to fix Wall & Closing Stiles.

ii)

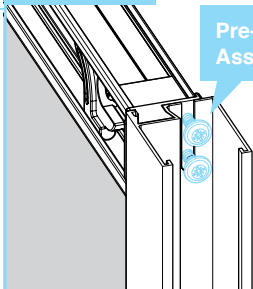

Inside View

9

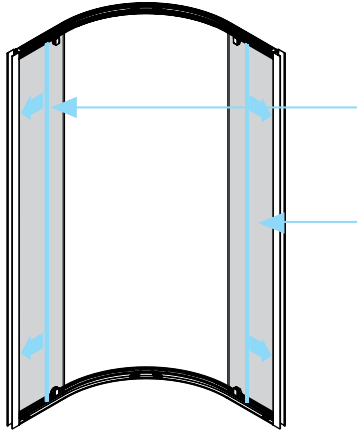

Inside View, Alternative Angle

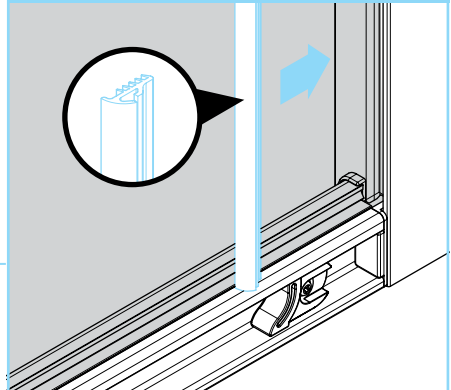

Please Note:
Gasket is supplied oversized,
please trim Gasket to suit.



IMPORTANT NOTE: Ensure Gasket is down tight against bottom Cill Profile for a watertight seal.



Tip:
Push fit Gasket, start at the bottom and work up.

Inside View

10

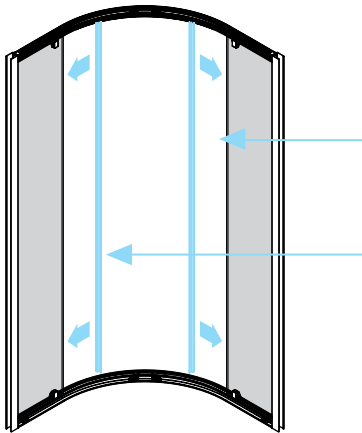

Inside View

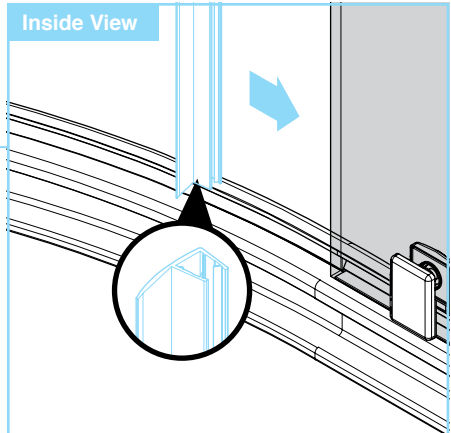

Tip:
To push fit Panel Blade Seal, start at the bottom and work up.



IMPORTANT NOTE: Ensure Panel Blade Seal is down tight against bottom Cill Profile.

11.1

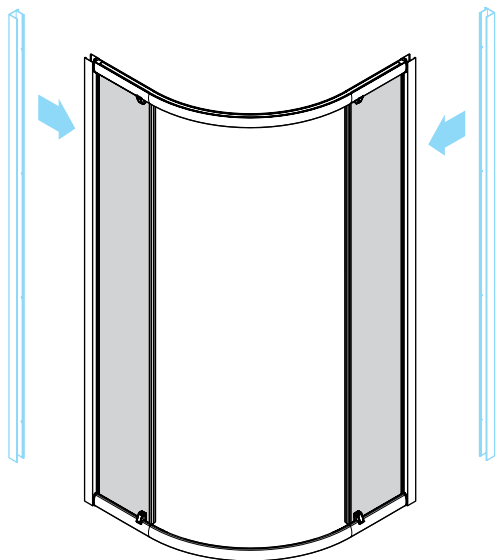

11.2

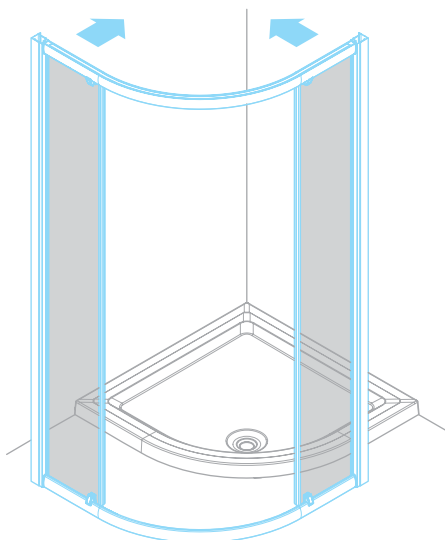

11.3

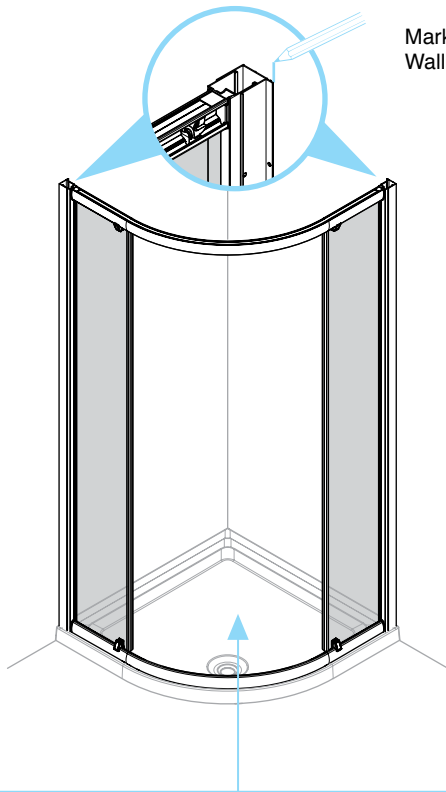

Mark position of Wall Channels

Plan View

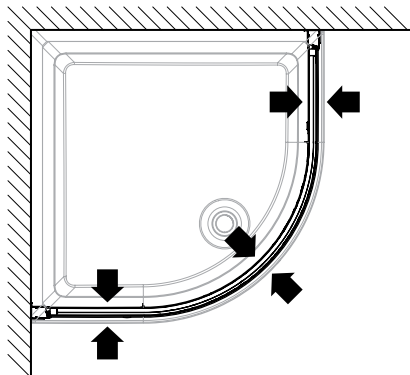

IMPORTANT NOTE

Ensure radius of enclosure matches tray.
DO NOT push frame fully into Wall Channel, allow a suitable gap to ensure adjustment and fixing.



Wall plugs supplied are for solid walls only. Ensure correct wall plug for wall type is used. If in doubt seek professional advice.



Position Wall Channel on wall as shown, ensure Wall Channel is fixed level.

12

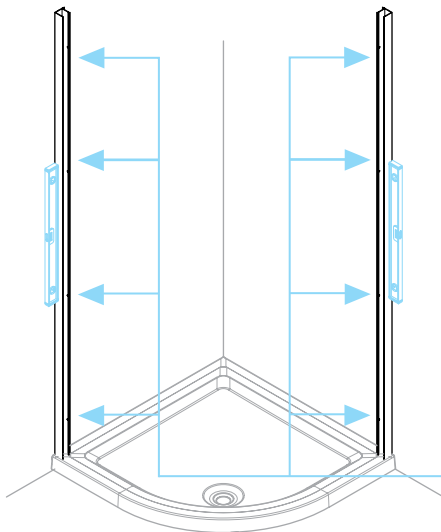

Inside View

12.1

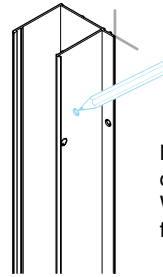

Mark position of pre-drilled Wall Channel fixing hole

12.2

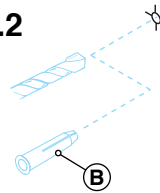

6mm dia. holes with drill bit suitable for wall surface

12.3

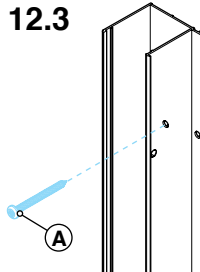

Fix through pre-drilled Wall Channel fixing hole



Tip: When drilling tiles apply masking tape to surface to stop drill bit slipping.

13

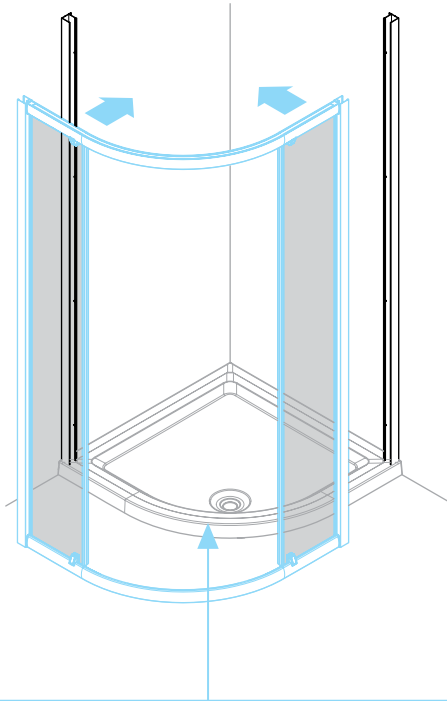

Plan View

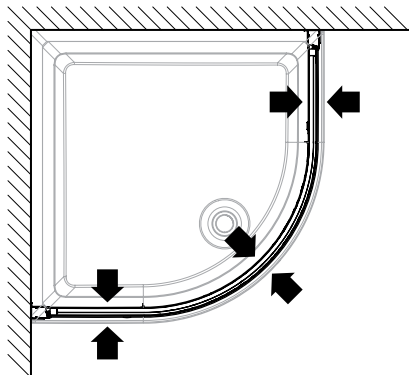

IMPORTANT NOTE

Ensure radius of enclosure matches tray.
DO NOT push frame fully into Wall Channel, allow a suitable gap to ensure adjustment and fixing.



Inside View

14

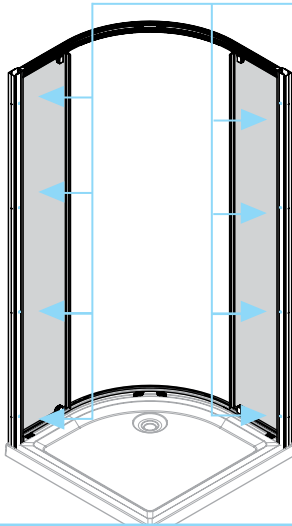

Ensure glass is positioned straight and is parallel with tray.

Inside View

*3mm dia. holes through pre-drilled holes using HSS drill bit

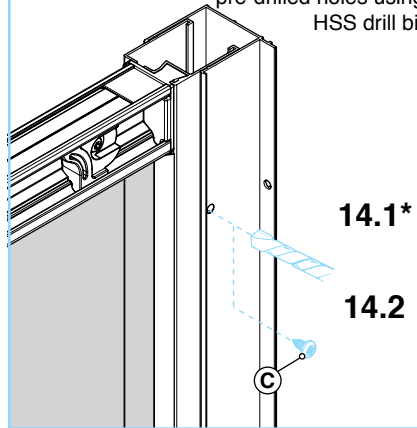

Tip: When inserting screws apply a small amount of oil to the screw thread to allow easier fixing.

Inside View

15

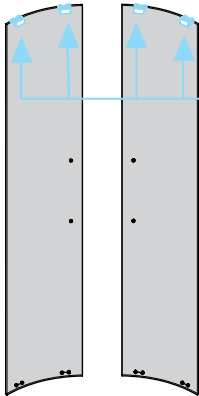

Please Note: Top Adjustable Bearings are supplied fully assembled. Disassemble part prior to fixing.



Please Note: Top adjustable Bearing and Bottom Spring Loaded Bearing variations. Use TOP ADJUSTABLE BEARING only.

Top Adjustable Bearing Fixing Preparation

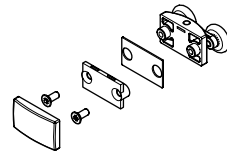

15.1

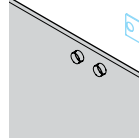

15.2

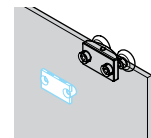

15.3

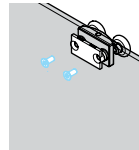

15.4

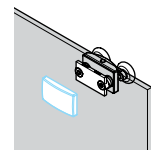

16

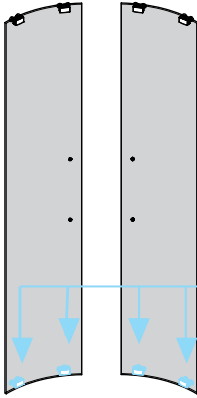

Bottom Spring Loaded Bearing Fixing Prep.

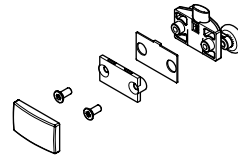

! Please Note: Bottom Spring Loaded Bearings are supplied fully assembled. Disassemble part prior to fixing.

! Please Note: Bottom Spring Loaded Bearing and Top adjustable Bearing variations. Use **BOTTOM SPRING LOADED BEARING** only.

16.1

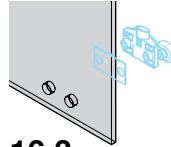

16.2

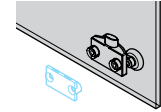

16.3

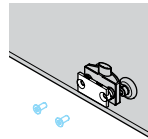

16.4

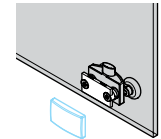

17

Inside View

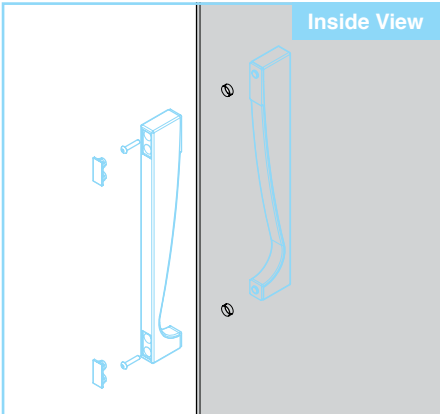

! Please Note: Door Handles are supplied assembled. Using Allen key supplied, disassemble part and then re-assemble as shown. Ensure all screw heads are on the enclosure interior. **DO NOT** overtighten.

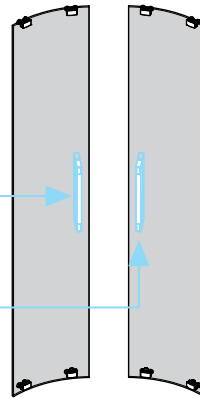

Inside View

18

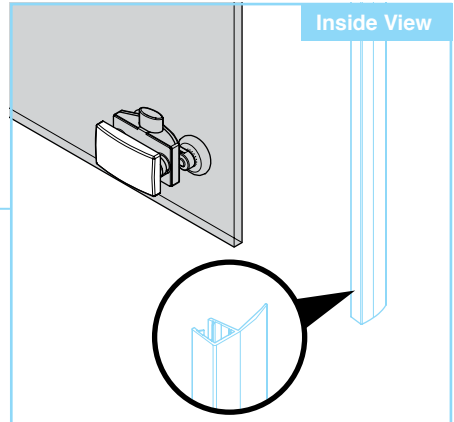
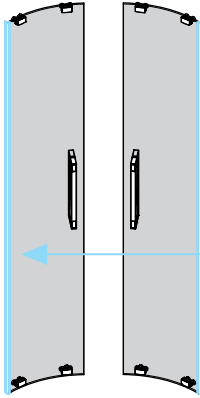

Ensure Door Blade Seal is fitted with blade facing away from enclosure, (as Shown).



Tip: Push fit Door Blade Seal, start at the bottom and work up.

Inside View

19

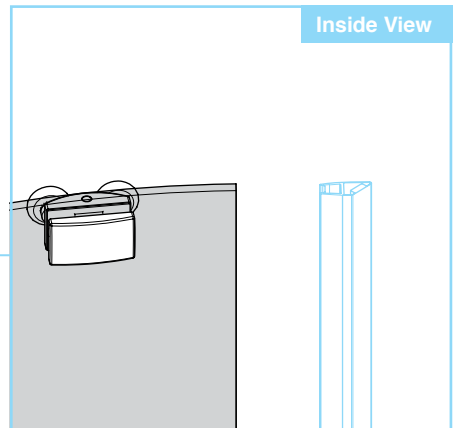
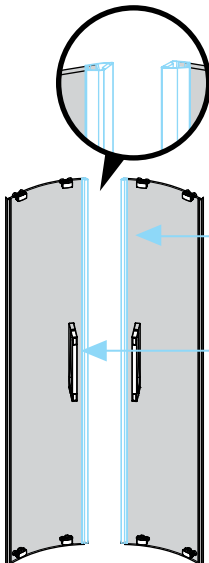

Ensure correct position of Magnet Seals, (as shown).



Tip: Push fit Magnet Seal, start at the bottom and work up.

Inside View

20

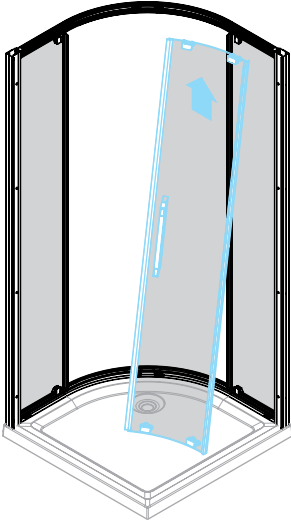

Tip:
Locate bearing wheels on the top rail first.

Inside View

21

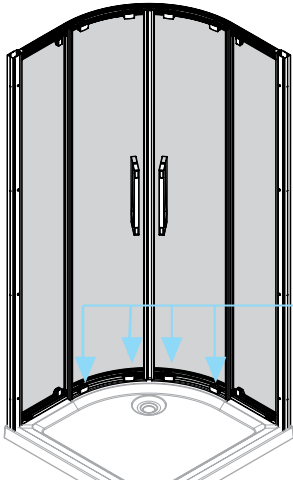

Tip:
Push button down and mount bearing wheels from the outside of the enclosure on to the rail, then release button to lock into place.

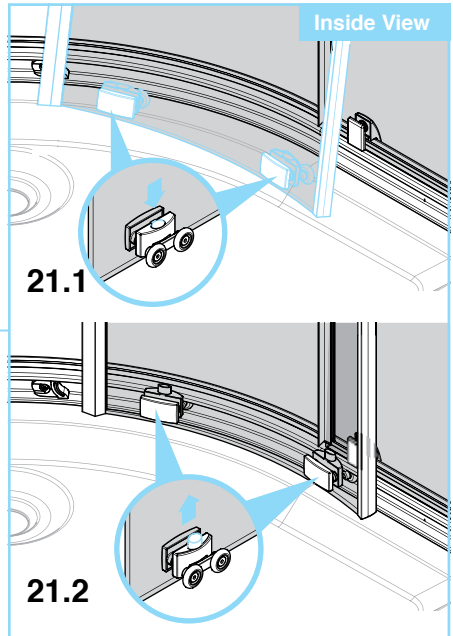

Inside View

22

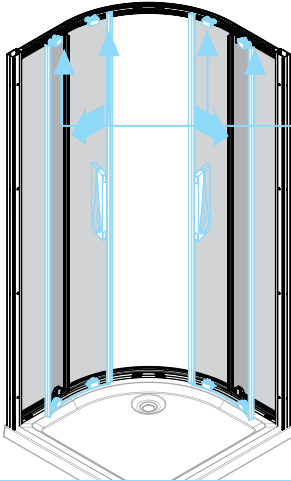

Tip:
When door is correctly located,
door position can be adjusted
up and down using Top Bearing
adjustment screws (right).

Inside, Underside View

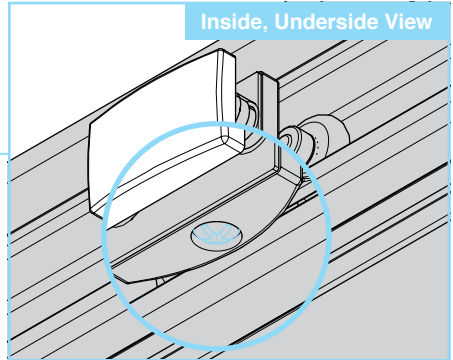

Using the adjustment in the Top
Bearings, ensure that the Bottom
Bearings are fully engaged into the
bottom Cill Rail. Adjustment may
also be used to ensure that the
Door closes correctly against the
Magnet Seals.



Ensure free movement of door.
Adjust to suit.

Inside View

23

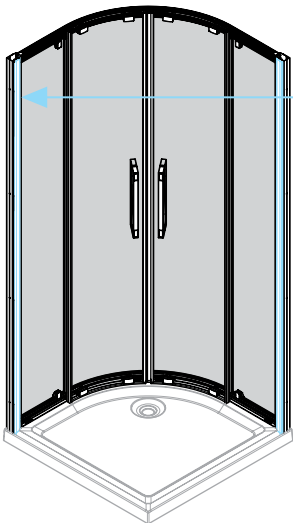

Inside View

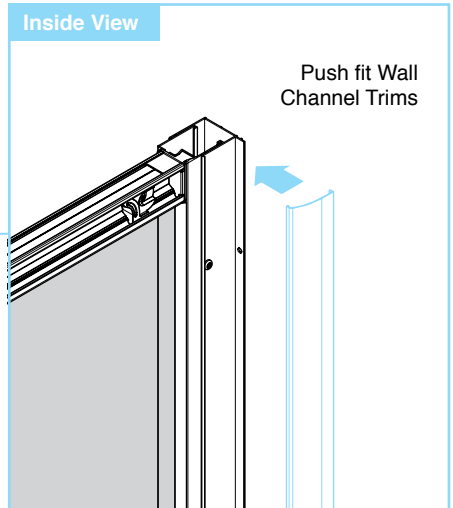

Push fit Wall
Channel Trims

Inside View

24

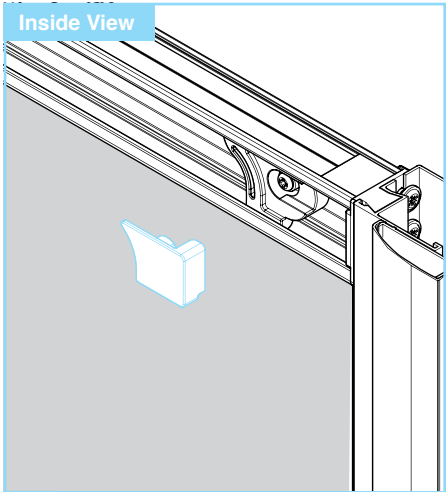

Push fit Door Stop Cover Caps.

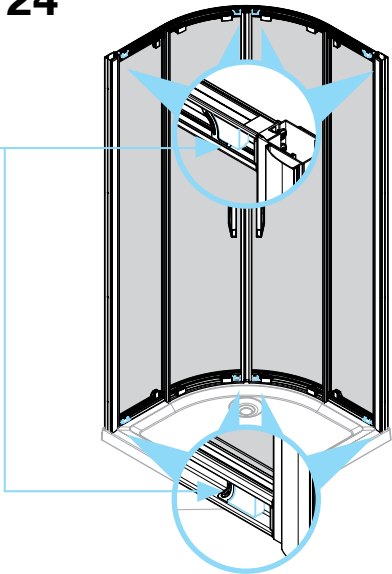

25

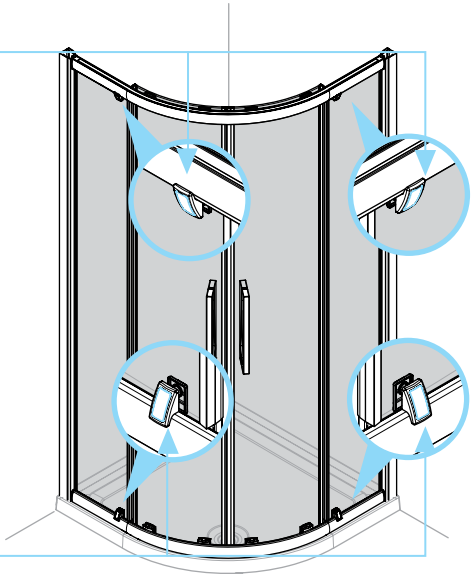
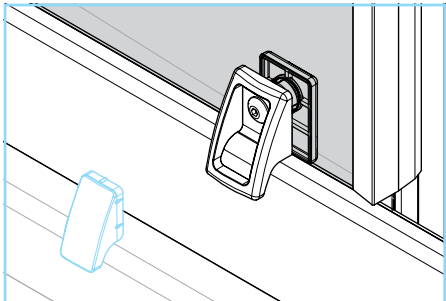
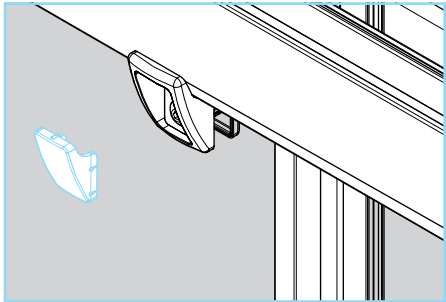

26

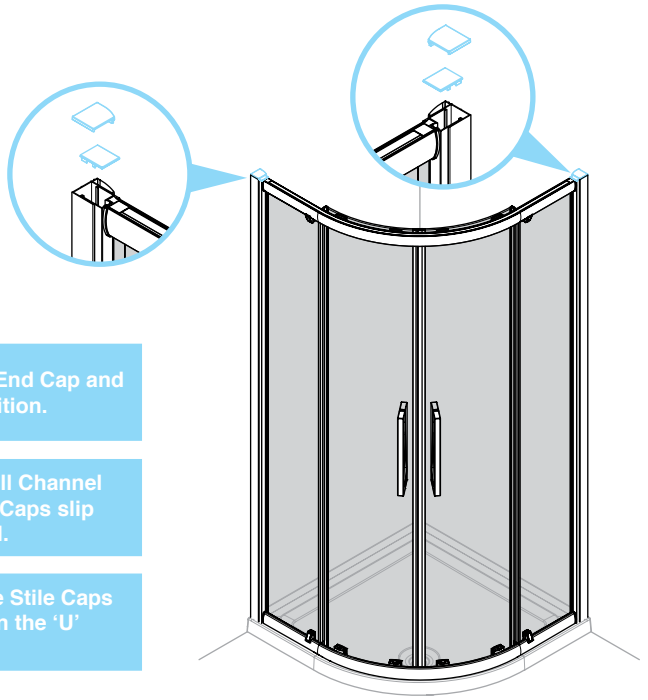

! Push fit Wall Channel End Cap and Stile End Cap into position.

***** Take care not to let Wall Channel End Caps or Stile End Caps slip down the Wall Channel.

***** For best results, locate Stile Caps at the back edge first in the 'U' feature.

Inside View

27

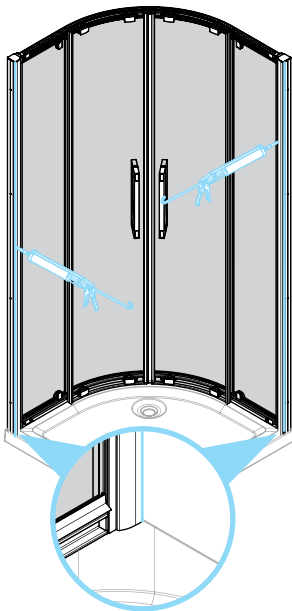

! Apply Silicone Sealant, (not supplied) vertically between wall channel and wall only.

! Apply Silicone Sealant, (not supplied).

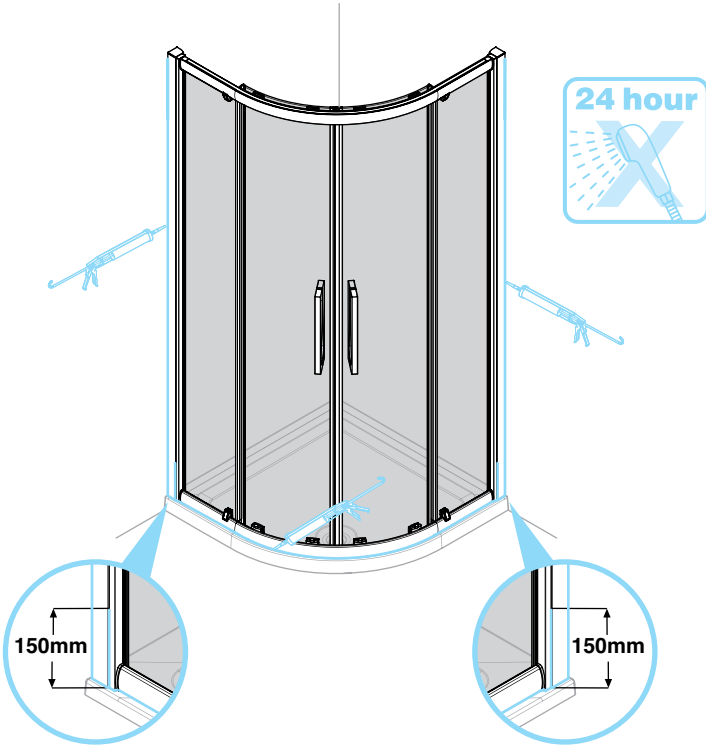

***** **Product Care:**
Use a non-abrasive cleaner.
Water marks may be removed with a proprietary limescale remover or household vinegar.

Notes:

Notes: