

IN00420 (rev A)

Aqua 6 Glide Sliding Door & Side Panel

AQUA 6
DESIGNED AROUND YOU

- Instruction suitable for both Right and Left Hand fixing variations.

IMPORTANT: If installing a Glide Sliding Door only; i.e. a recess installation, please refer to alternative fixing details on the document reverse.

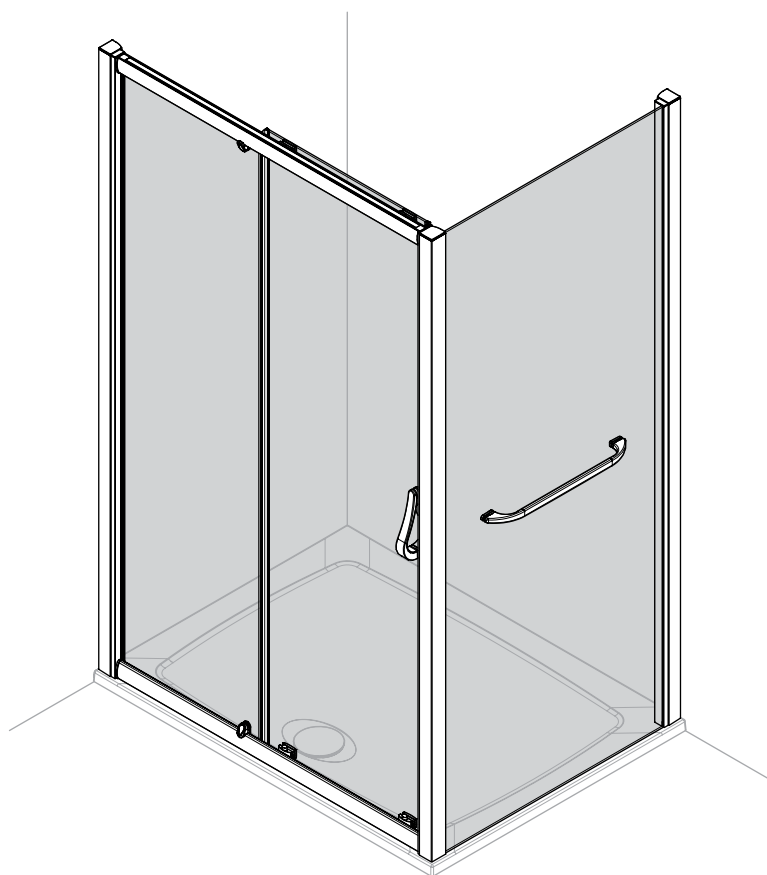

Before You Start

- Check that the tray has been installed correctly and that it is level (Fig. A), tiled down onto and sealed to the manufacturer's guidelines. **Please Note:** All product supplied without tray.
- Ensure the product is fitted to a non-porous surface ie. tiled. Check that the wall surface is flat.
- Unpack and check the product is complete and undamaged.
- Fixings are supplied for solid walls only. Ensure that the correct fixings are used for the wall type – if in doubt seek professional advice.
- Ensure the area is clean, dry and dust free.
- Read the instructions in full.
- Have the correct tools available, (as shown below, see 'Tools Required').
- It is recommended to situate the showerhead and door adjacent to each other in order to allow any water spray to be on the side panel or upstanding wall.

Fig.A.

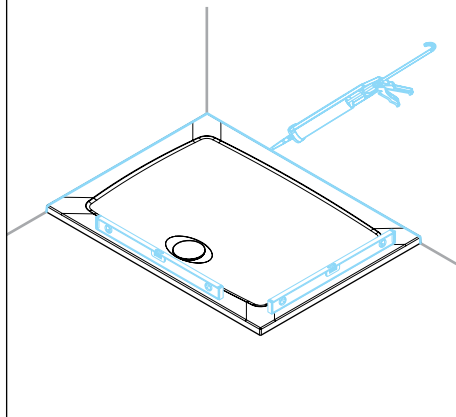

Safety

- Handle all glass with care - support on cardboard to avoid risk of breakage.
- This product is heavy and requires 2 people to carry and install it.
- When drilling walls check first for hidden pipes and cables.
- All glass is toughened – it cannot be reworked or replaced by ordinary glass.
- Use safety eyewear when drilling.
- Use safety eyewear when handling glass.
- Keep all small parts away from children.

Disclaimer

- Please notify the retailer immediately of any damage or faults. The manufacturer cannot be held responsible for any installation costs that may arise from damaged or faulty product being installed.
- Please dispose of all packaging with due regard to the environment.

Tools Required (not supplied)

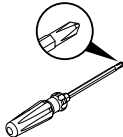
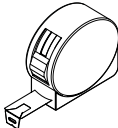
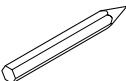
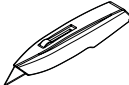
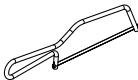
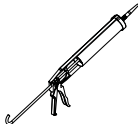
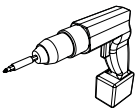
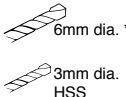
<p>Spirit Level</p> 	<p>Screwdriver</p> 	<p>Tape Measure</p> 	<p>Pencil</p> 	<p>Utility Knife</p> 
<p>Junior Hacksaw</p> 	<p>Silicone Gun & Sealant</p> 	<p>Power Drill</p> 	<p>Suitable Drill Bits</p>  <p>6mm dia. *</p> <p>3mm dia. HSS</p>	<p>* Ensure drill bit used is suitable for wall surface</p>



Help Line: 0870 241 6131

Lines open: 8.30am - 5.00pm Monday to Friday
Standard National call charge rate from BT landlines

Parts & Fittings Supplied



Please notify the retailer immediately of any damage or faults. The manufacturer cannot be held responsible for any installation costs that may arise from a damaged or faulty product being installed.



Keep small parts away from children

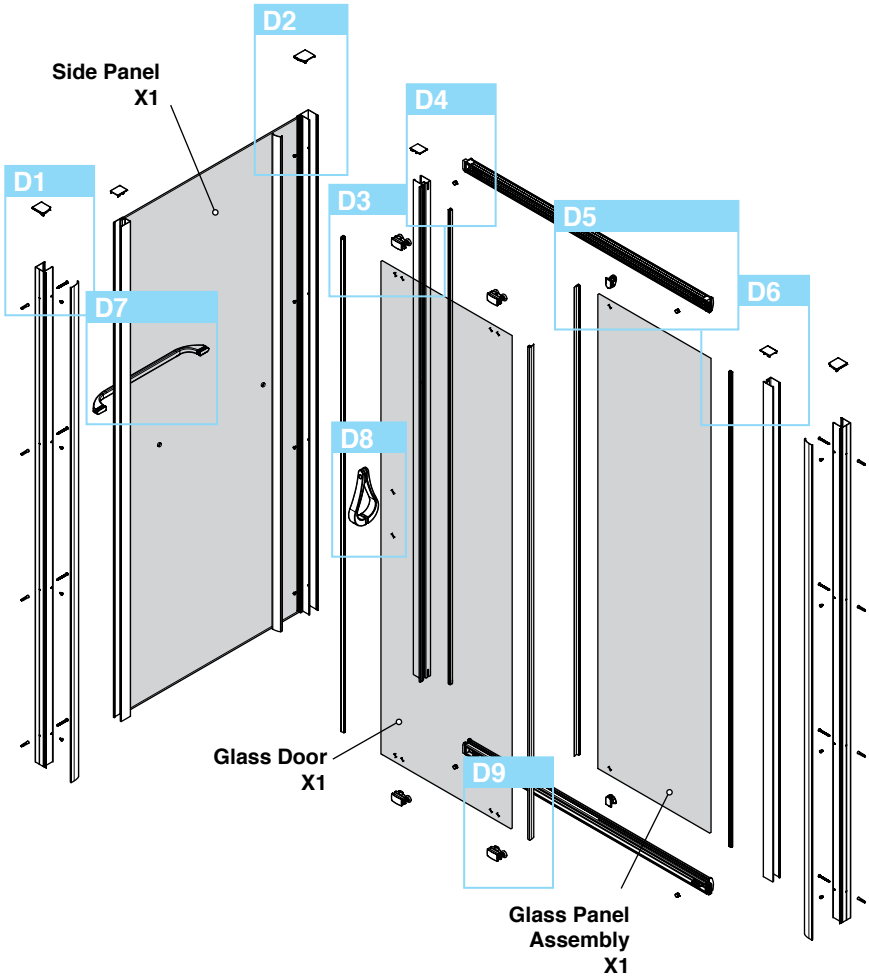

Allen Keys Supplied



3mm Allen Key

D1

*Left and right hand variants supplied

All components are supplied with Pivot Door Pack

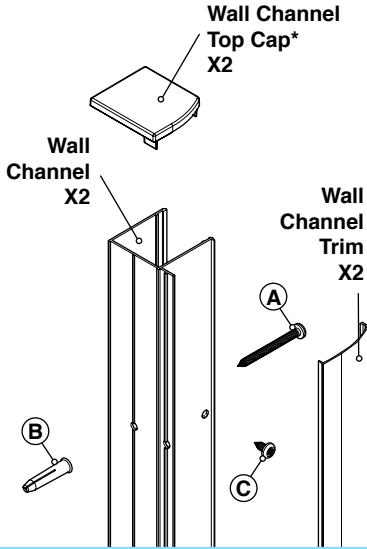

D2

*Left and right hand variants supplied.

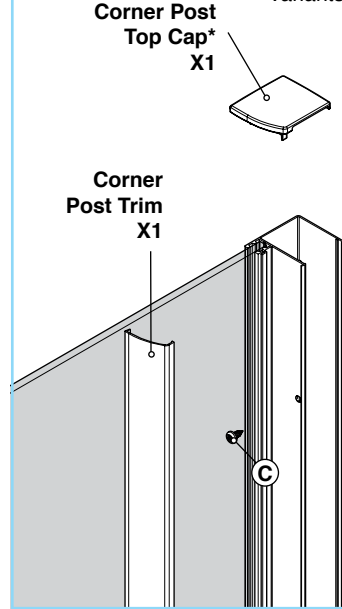

D3

Top Adjustable Bearing X2

Magnet Seal X1

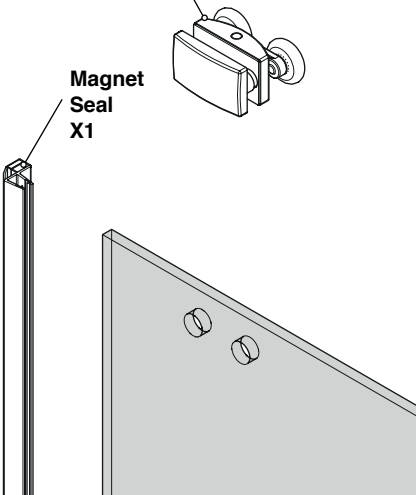

D4

** 1 no. cap supplied with side panel pack

Stile Cap** X3

Closing Stile Assembly X1

Infill Gasket X1

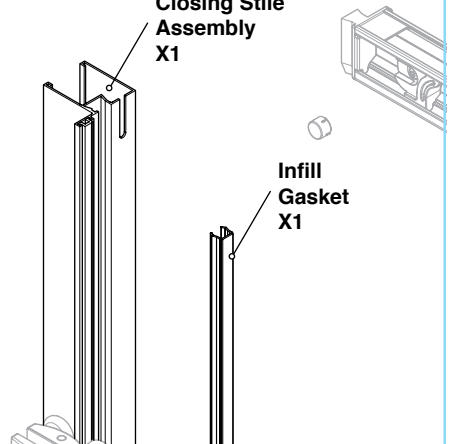

D5

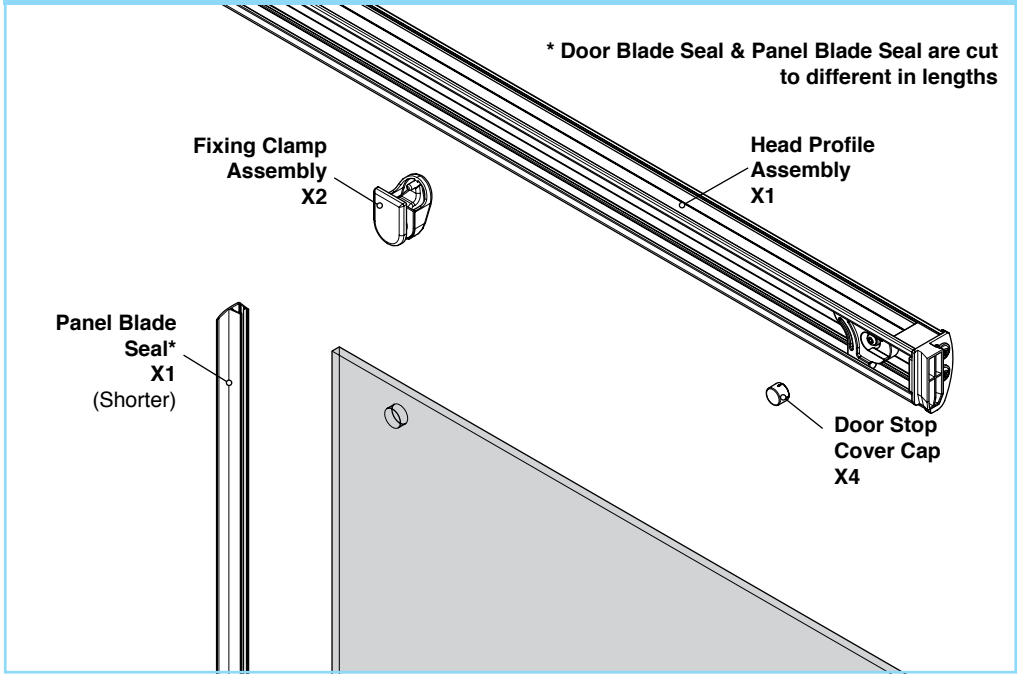

D6

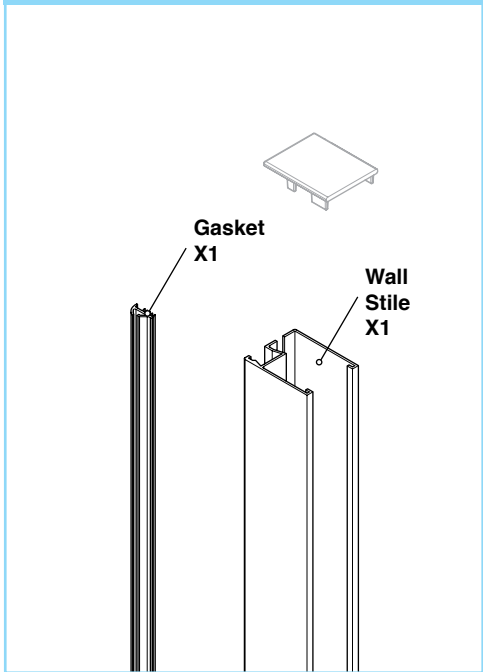

D7

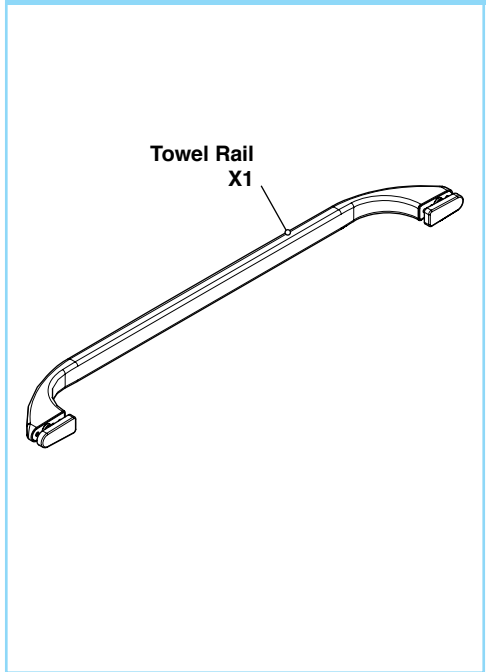

D8

Door Handle Assembly
X1

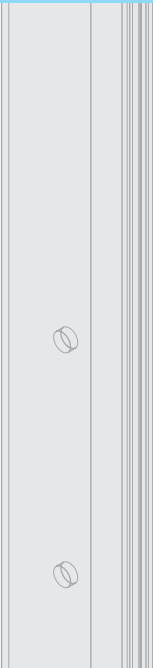
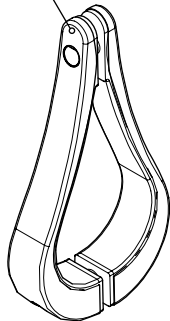

D9

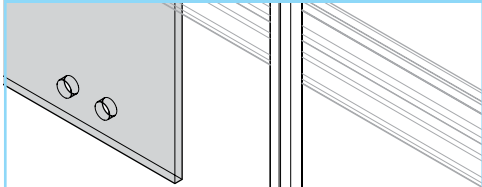

Bottom Spring Loaded Bearing
X2

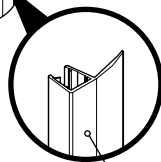
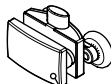

Door Blade Seal
X1
(Longer)

Loose Screws & Fittings Supplied

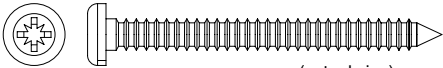
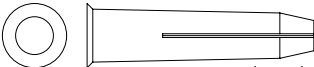
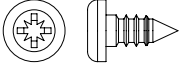
(A)	No.8 x 1 $\frac{3}{4}$ " Pan Head Pozi Screws	 (actual size)	Qty x8
(B)	Wall Plugs	 (actual size)	Qty x8
(C)	No.8 x $\frac{3}{8}$ " Pan Head Pozi Screws	 (actual size)	Qty x12

IMPORTANT NOTE:

This installation instruction is shown with a right hand entry to the enclosure and a right hand side panel (see below). If you would like to build your product as a variation of this (i.e. Left hand entry with left hand side panel) please mirror the details as necessary.

If in doubt please seek advise before commencing with the installation.

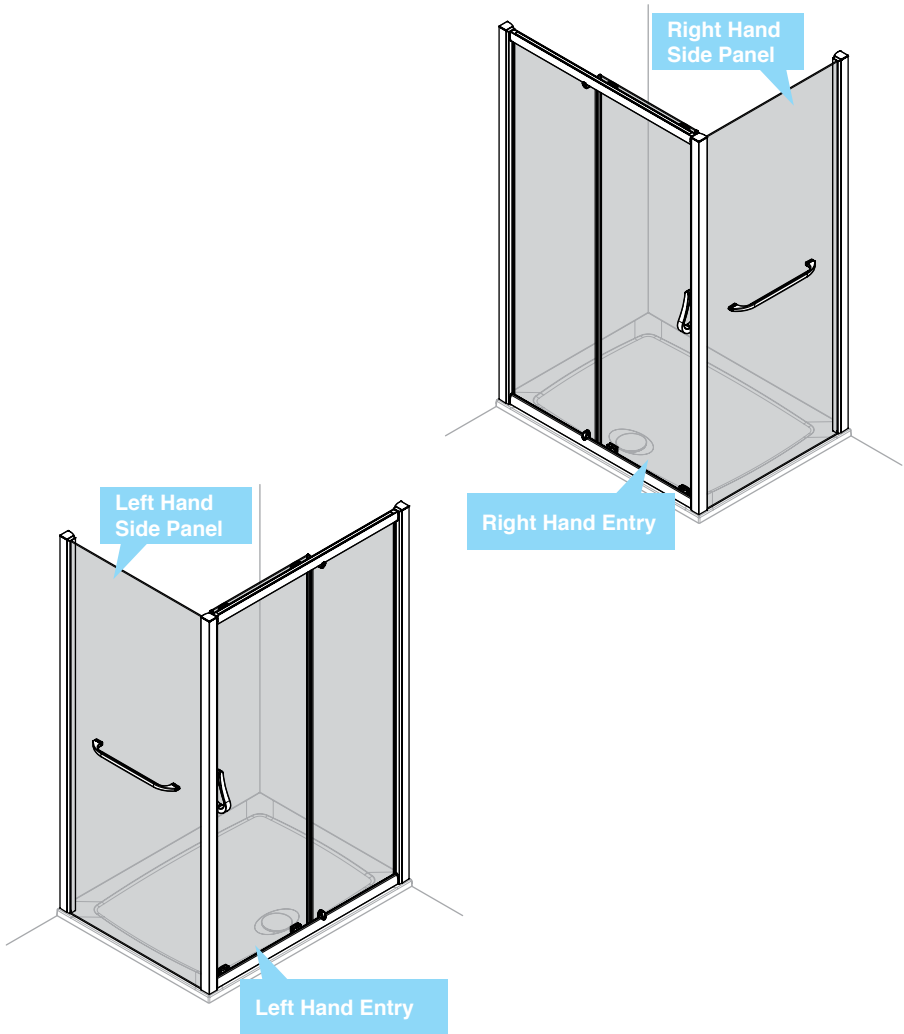

1.1

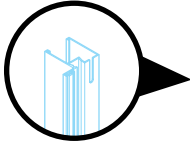

Slide Closing Stile Assembly into position onto Cill Profile Assembly*

! IMPORTANT NOTE:
Ensure that this assembly (1-10) is carried out on a flat / level surface.

! Ensure correct Closing Stile and Cill Assembly orientation.

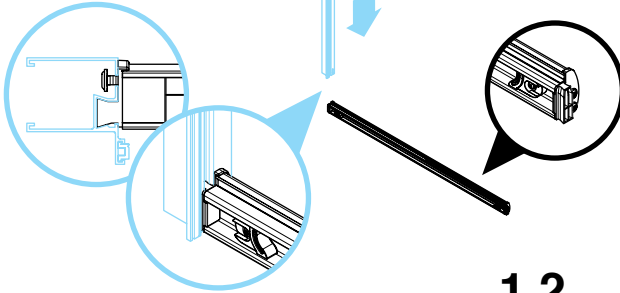

1.2

Slide Stile into position on Cill Assembly Profile as shown*

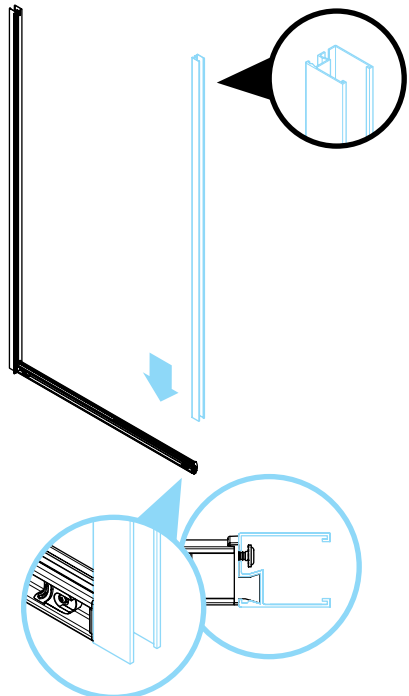
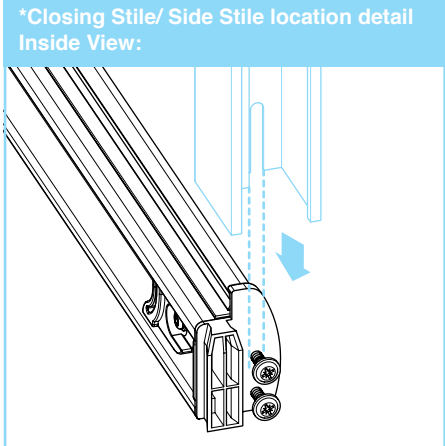

Inside View

2

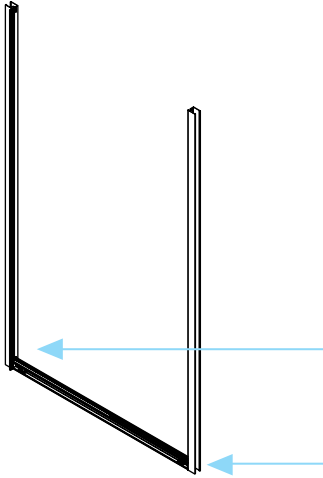

IMPORTANT NOTE:
Ensure product is assembled on a level surface/ floor and that the frame assembly is straight and level.

Inside View

i)

Pre-fitted Cill Assembly screws.

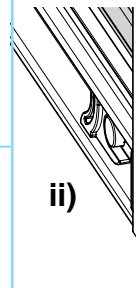

ii)

Tighten pre-fitted Cill Assembly screws to fix Wall & Closing Stiles.

Inside View

3.1

Inside View, Alternative Angle

i)

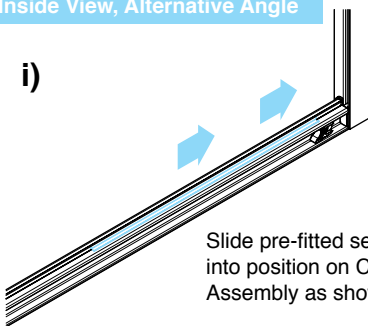

Slide pre-fitted seal into position on Cill Assembly as shown

ii)

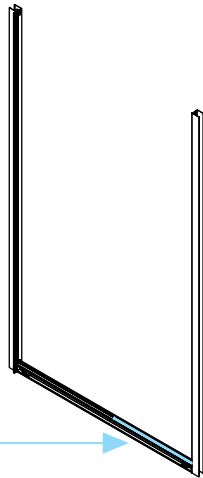
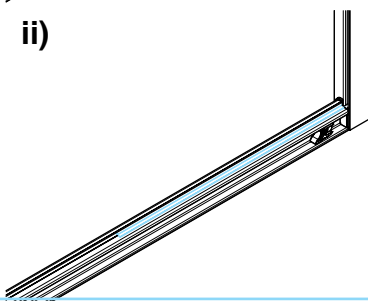

Ensure pre-fitted seal on Cill Profile Assembly is pushed up against Stile.

3.2

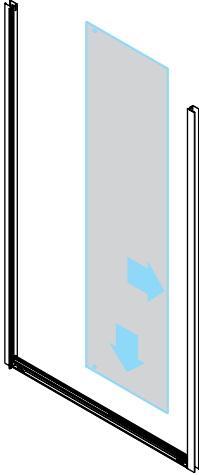

Please take care when handling glass.



Locate Glass Front Panel into Stile.

Inside View

4

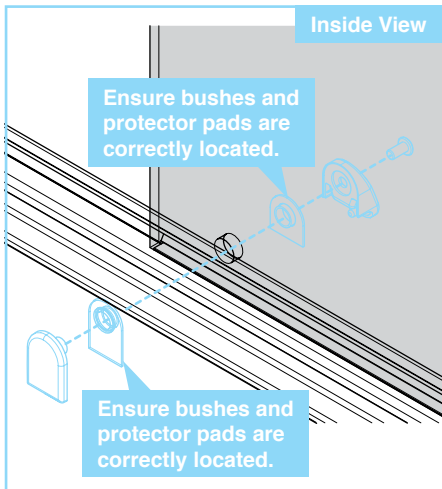

Ensure bushes and protector pads are correctly located.

Ensure bushes and protector pads are correctly located.



Please Note: Fixing Brackets are supplied assembled. Using Allen key supplied, disassemble part and then re-assemble as shown. DO NOT overtighten.

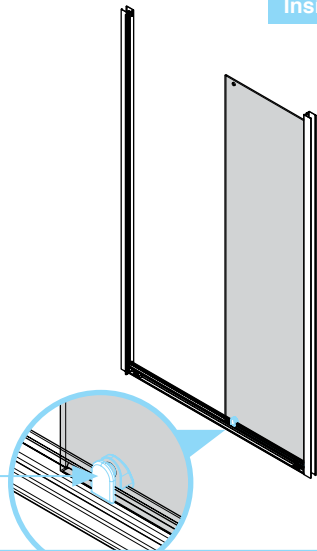

DO NOT fit cover cap at this stage. Screw heads are on OUTSIDE of the enclosure.

Inside, Underside View

i)

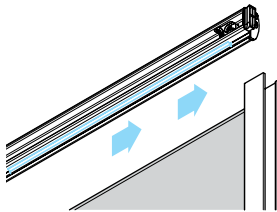

Slide pre-fitted seal into position on Head Assembly as shown

ii)

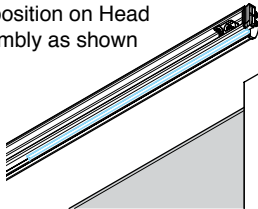

Ensure pre-fitted seal on Head Profile Assembly is pushed up against Stile prior to slotting Head Profile Assembly into position.

5

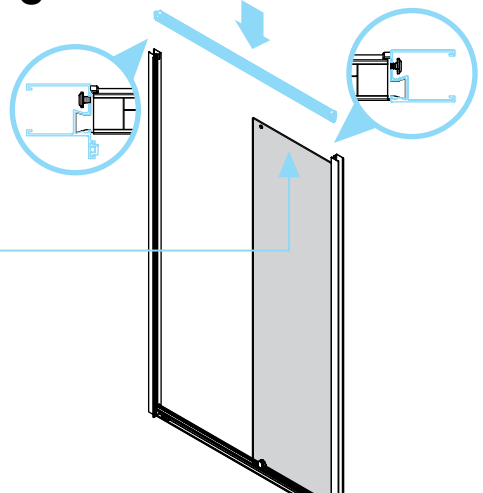

Ensure that the Head Profile Assembly is push right down on top of glass panels.

Inside View

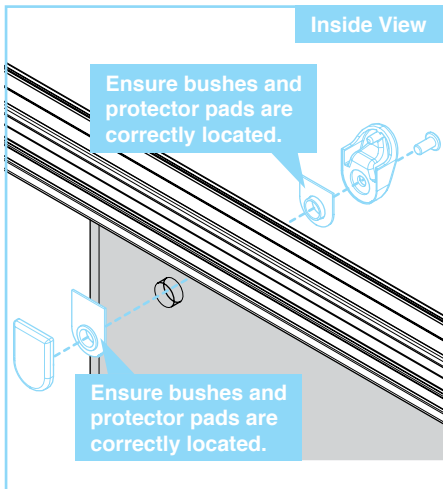

Ensure bushes and protector pads are correctly located.

Ensure bushes and protector pads are correctly located.

Please Note: Fixing Brackets are supplied assembled. Using Allen key supplied, disassemble part and then re-assemble as shown. DO NOT overtighten.

6

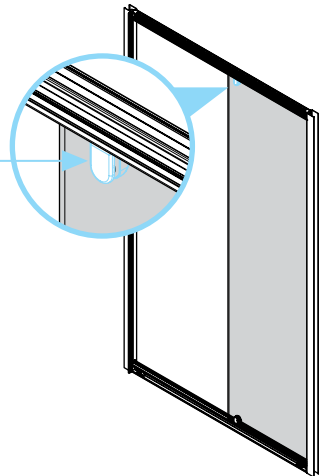

DO NOT fit cover cap at this stage. Screw heads are on OUTSIDE of the enclosure.

Inside View

7

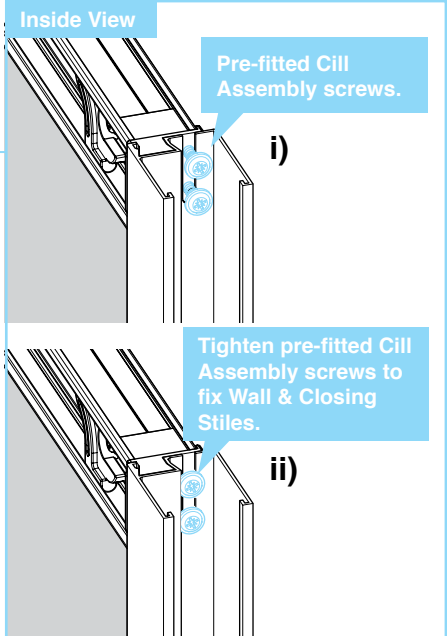
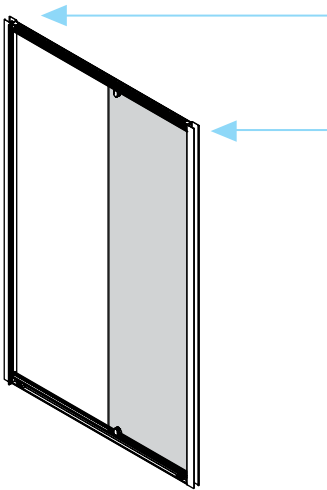

Pre-fitted Cill Assembly screws.

i)

Tighten pre-fitted Cill Assembly screws to fix Wall & Closing Stiles.

ii)

! **IMPORTANT NOTE:** Ensure that Head Assembly is located on top of glass prior to tightening pre-fitted screws.

Inside View

8

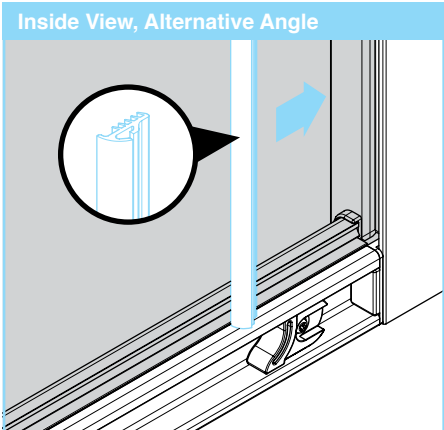

Inside View, Alternative Angle

! **Please Note:** Gasket is supplied oversized, please trim Gasket to suit.

***** **Tip:** Push fit Gasket, start at the bottom and work up.

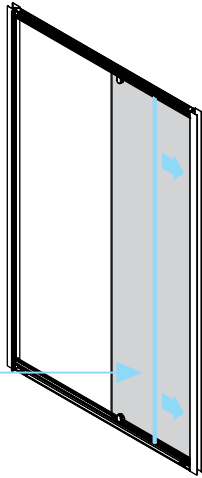

! **IMPORTANT NOTE:** Ensure Gasket is down tight against bottom Cill Profile for a watertight seal.

Inside View

9

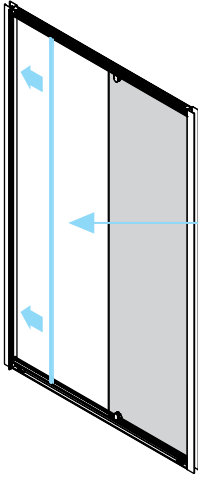

Inside View

Push fit Infill Gasket into Closing Stile Assembly

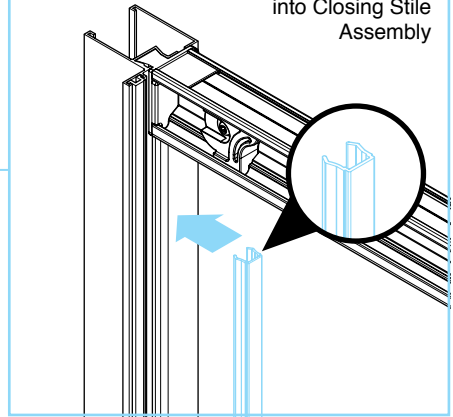

Inside View

10

Inside View

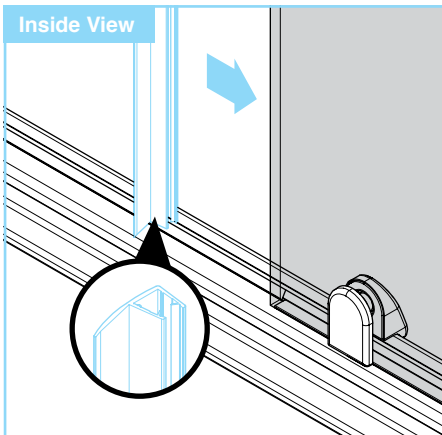

Tip:
To push fit Panel Blade Seal, start at the bottom and work up.

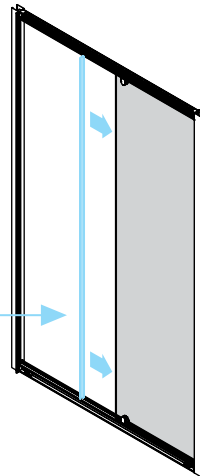

IMPORTANT NOTE: Ensure Panel Blade Seal is down tight against bottom Cill Profile.

11.1

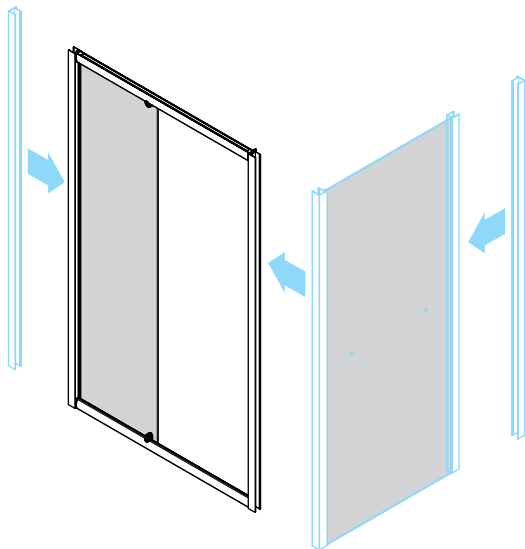

11.2

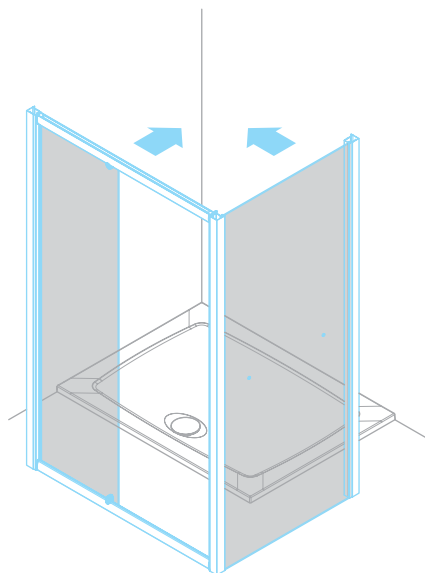

11.3

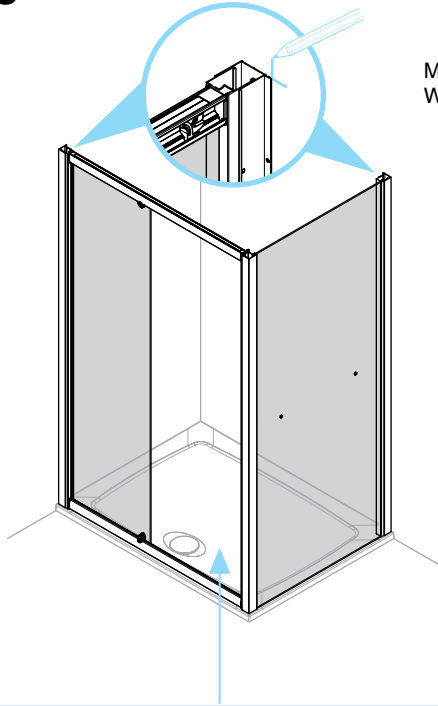

Mark position of Wall Channels

Plan View

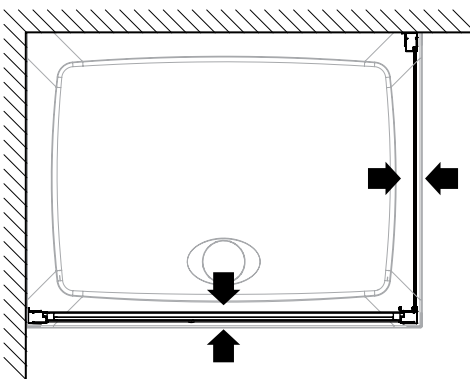

! Ensure glass is positioned straight and is parallel with tray.

IMPORTANT NOTE:

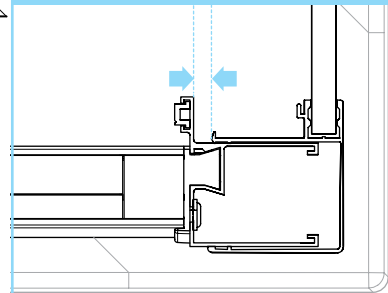

! Ensure adequate gap between corner post (on Side Panel) and Closing Stile or Wall Stile (on Frame Assembly) for Corner Post Trim to be fitted as shown in step 25.



Wall plugs supplied are for solid walls only. Ensure correct wall plug for wall type is used. If in doubt seek professional advice.



Position Wall Channel on wall as shown, ensure Wall Channel is fixed level.

12

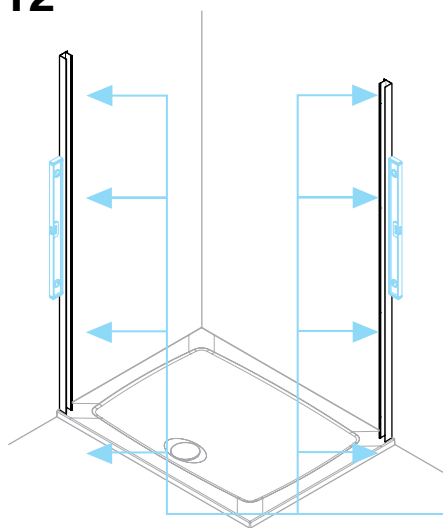

Inside View

12.1

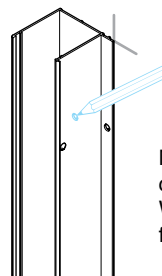

Mark position of pre-drilled Wall Channel fixing hole

12.2

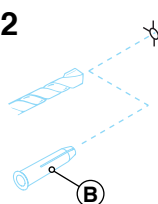

6mm dia. holes with drill bit suitable for wall surface

12.3

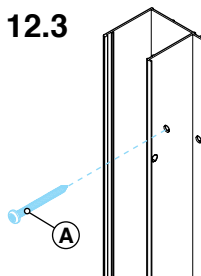

Fix through pre-drilled Wall Channel fixing hole



Tip: When drilling tiles apply masking tape to surface to stop drill bit slipping.

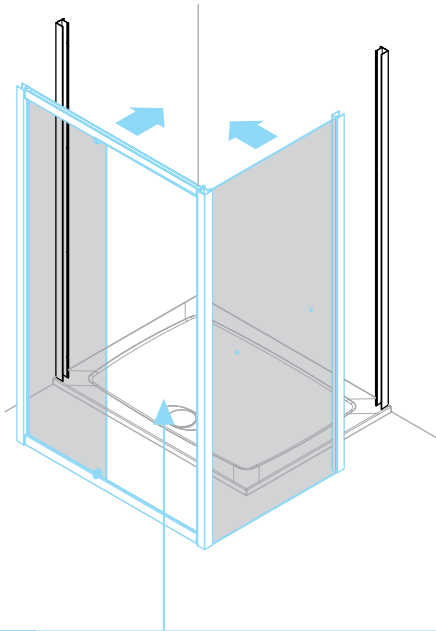

Plan View

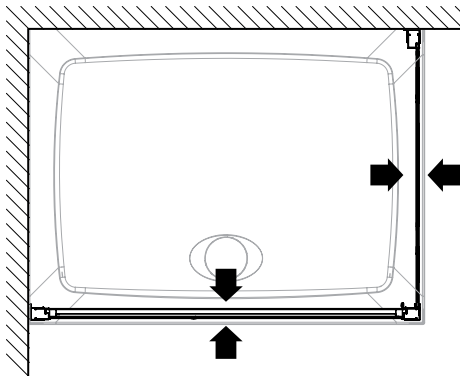

Ensure glass is positioned straight and is parallel with tray.

IMPORTANT NOTE:

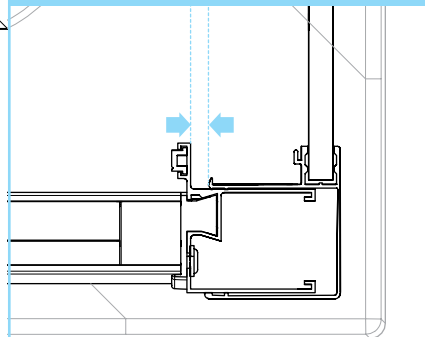

Ensure adequate gap between corner post (on Side Panel) and Closing Stile or Wall Stile (on Frame Assembly) for Corner Post Trim to be fitted as shown in step 25.

Inside View

14

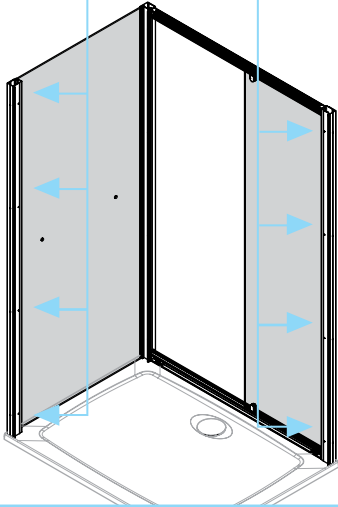

Ensure glass is positioned straight and is parallel with tray.

Inside View

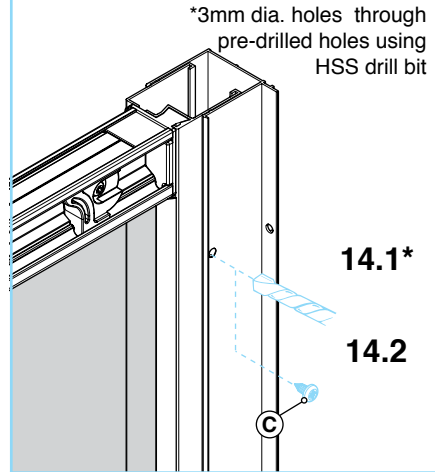

Tip: When inserting screws apply a small amount of oil to the screw thread to allow easier fixing.

Inside View

15

*3mm dia. holes through pre-drilled holes using HSS drill bit

Inside View

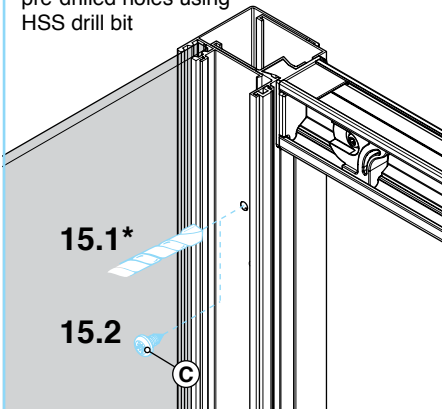

Ensure adequate gap between corner post profile and vertical door stile so that Corner Post Trim can be fitted afterwards in Step 25.

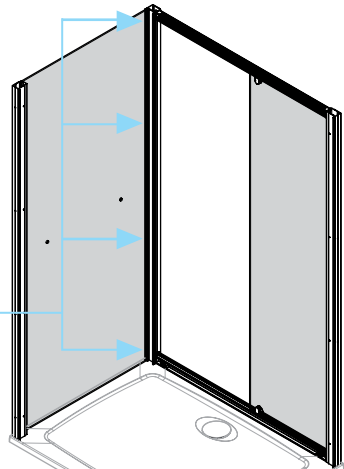

Tip: When inserting screws apply a small amount of oil to the screw thread to allow easier fixing.

16

Inside View

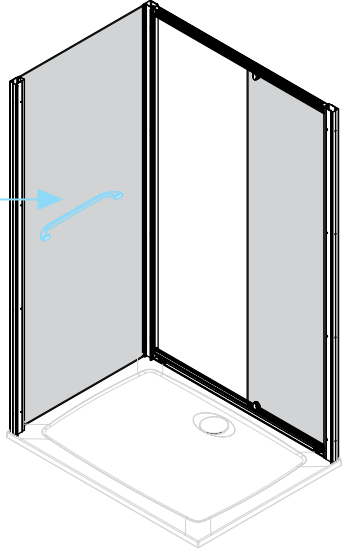
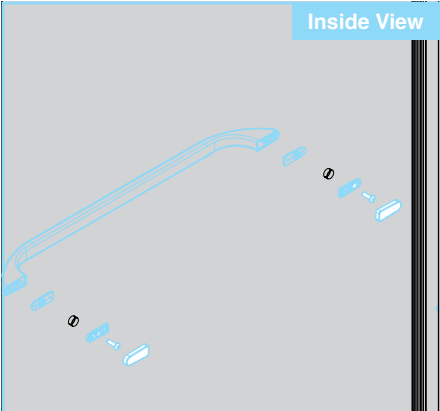

Please Note: Towel Rail is supplied assembled. Using Allen key supplied, disassemble part and then re-assemble as shown. Ensure all screw heads are on the enclosure interior. **DO NOT** overtighten.



Inside View

17

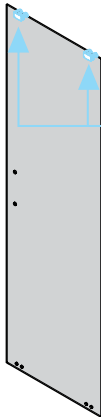

Top Adjustable Bearing Fixing Preparation

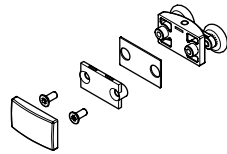

17.1

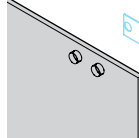

17.2

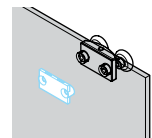

17.3

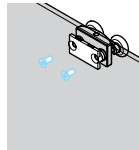

17.4

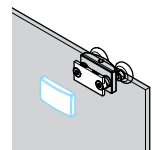

Please Note: Top Adjustable Bearings are supplied fully assembled. Disassemble part prior to fixing.



Please Note: Top adjustable Bearing and Bottom Spring Loaded Bearing variations. Use **TOP ADJUSTABLE BEARING** only.

18



! Please Note: Bottom Spring Loaded Bearings are supplied fully assembled. Disassemble part prior to fixing.

! Please Note: Bottom Spring Loaded Bearing and Top adjustable Bearing variations. Use **BOTTOM SPRING LOADED BEARING** only.

Bottom Spring Loaded Bearing Fixing Prep.

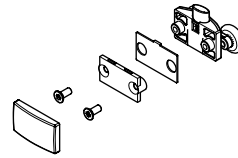

18.1

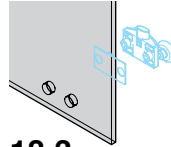

18.2

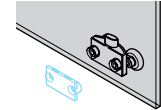

18.3

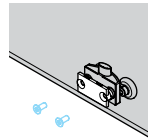

18.4

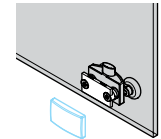

19

Inside View

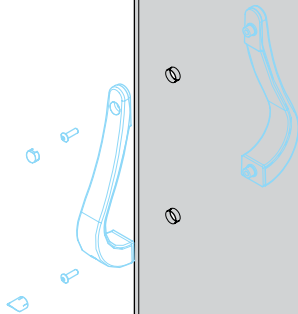

! Please Note: Door Handles are supplied assembled. Using Allen key supplied, disassemble part and then re-assemble as shown. Ensure all screw heads are on the enclosure interior. **DO NOT** overtighten.



20

Inside View

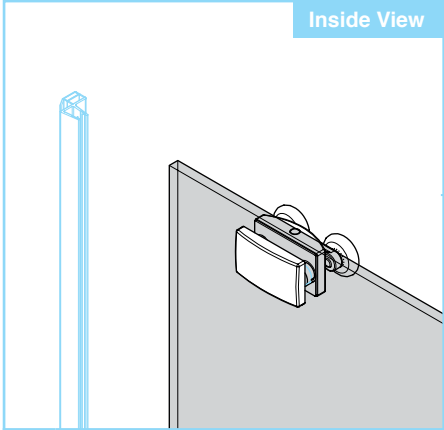

! Ensure Magnet Seal is fitted with magnet positioned on the **OUTSIDE** of the door, (as Shown).

***** Tip: Push fit Magnet Seal, start at the bottom and work up.

21

Inside View

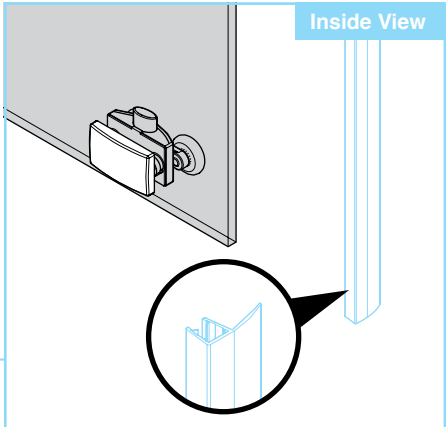

! Ensure Door Blade Seal is fitted with blade facing away from enclosure, (as Shown).

***** Tip: Push fit Door Blade Seal, start at the bottom and work up.

Inside View

22

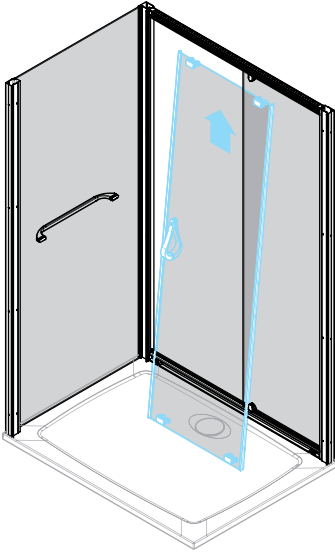

Tip:
Locate bearing wheels on the top rail first.

Inside View

23

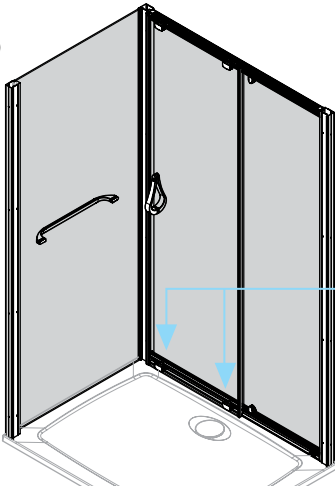

Tip:
Push button down and mount bearing wheels from the outside of the enclosure on to the rail, then release button to lock into place.

Inside View

23.1

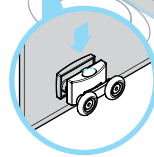

23.2

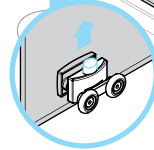

Inside View

24

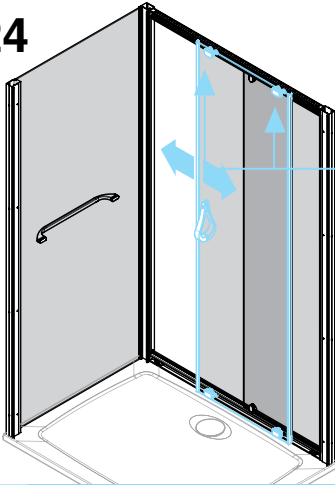

Tip: When door is correctly located, door position can be adjusted up and down using Top Bearing adjustment screws (right).

Inside, Underside View

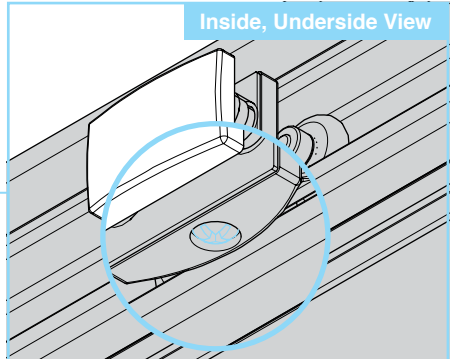

Using the adjustment in the Top Bearings, ensure that the Bottom Bearings are fully engaged into the bottom Cill Rail. Adjustment may also be used to ensure that the Door closes correctly against the Magnet Seal.



Ensure free movement of door. Adjust to suit.

Inside View

25

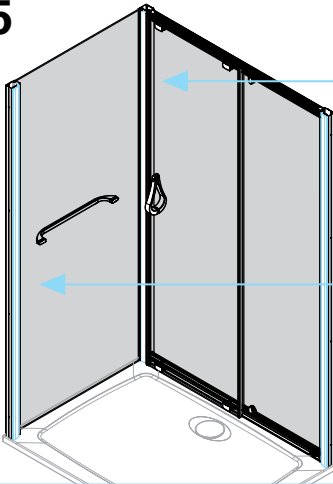

Please Note: Wall Channel Trim and Corner Post Trim are different, ensure correct trim type is used.

Inside View

25.1

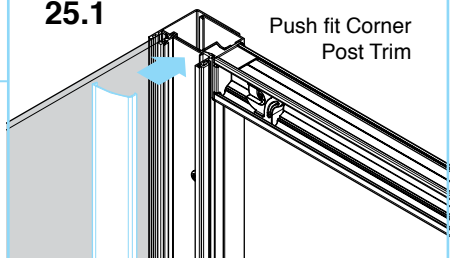

Push fit Corner Post Trim

Inside View

25.2

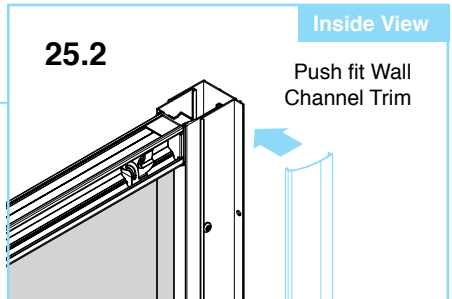

Push fit Wall Channel Trim

26

Inside View

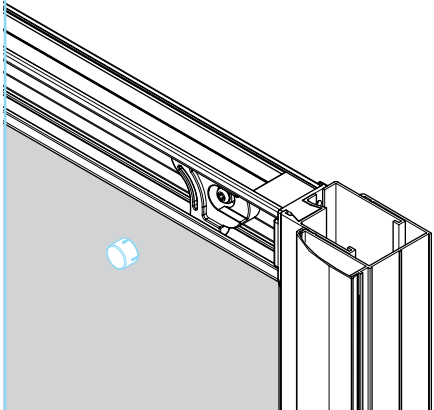

Push fit Door Stop Cover Caps.

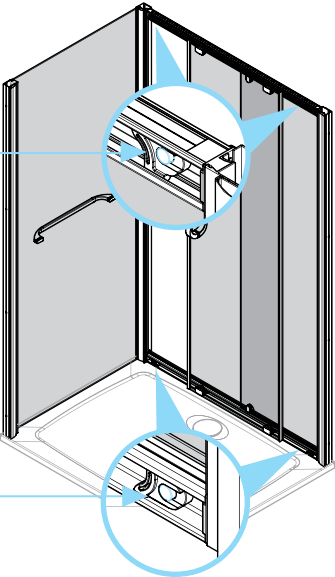

27

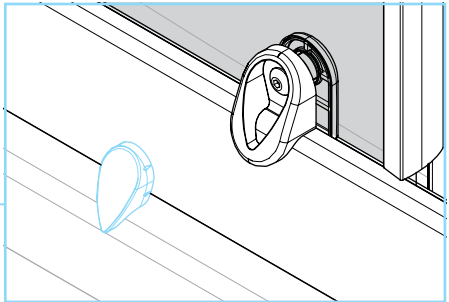
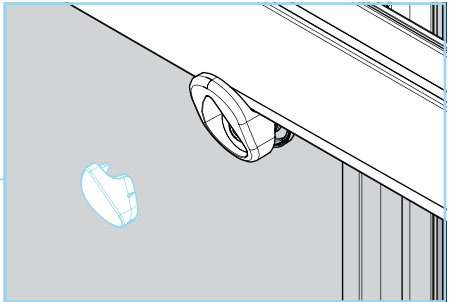
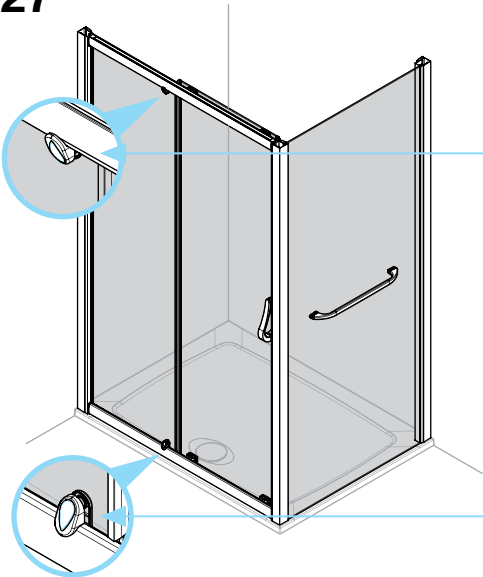

28

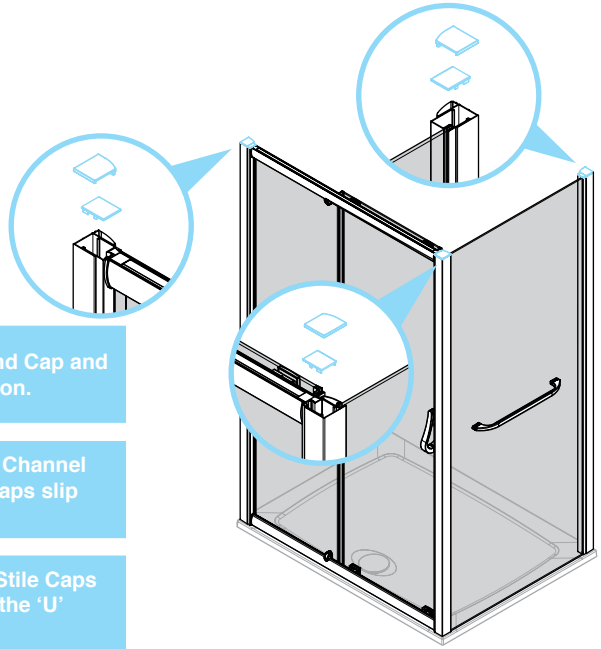

! Push fit Wall Channel End Cap and Stile End Cap into position.

***** Take care not to let Wall Channel End Caps or Stile End Caps slip down the Wall Channel.

***** For best results, locate Stile Caps at the back edge first in the 'U' feature.

Inside View

29



! Apply Silicone Sealant, (not supplied) horizontally between glass and tray only.

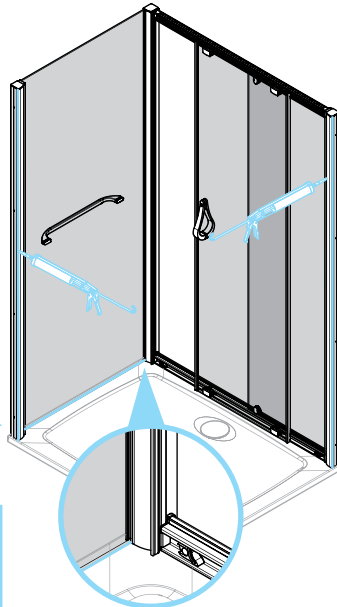
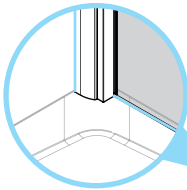

! Apply Silicone Sealant, (not supplied) vertically between wall channel and wall only.

! Apply Silicone Sealant, (not supplied).

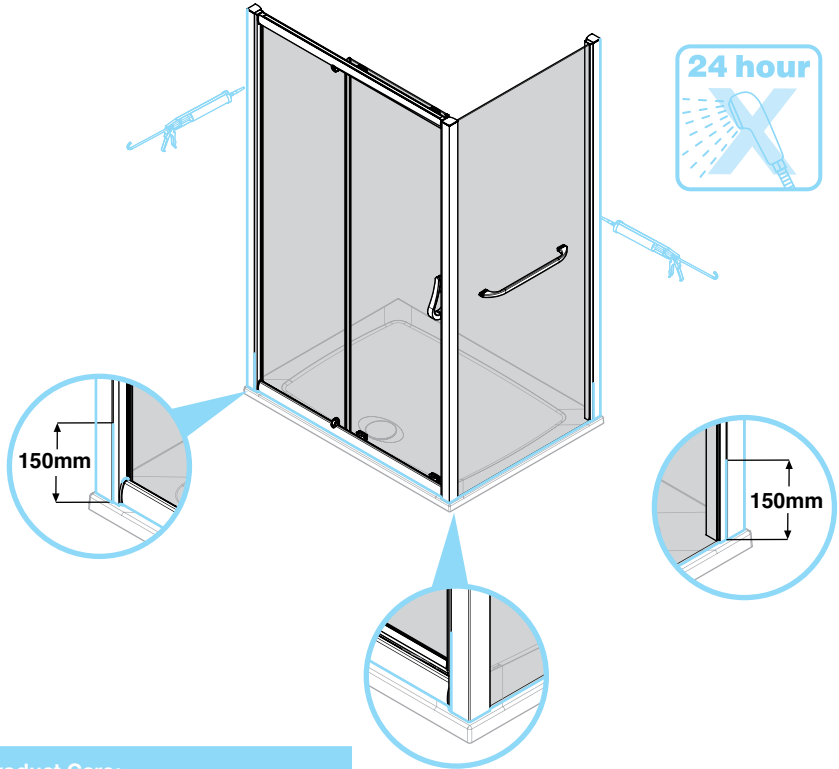

***** Product Care:
Use a non-abrasive cleaner.
Water marks may be removed with a proprietary limescale remover or household vinegar.

IN00420 (rev A)

Aqua 6 Glide Sliding Door

• Instruction suitable for both Right and Left Hand fixing variations.

AQUA 6

DESIGNED AROUND YOU

IMPORTANT: If installing a Glide Sliding Door and Side Panel only; ie. a corner installation, please refer to alternative fixing details on the document reverse.

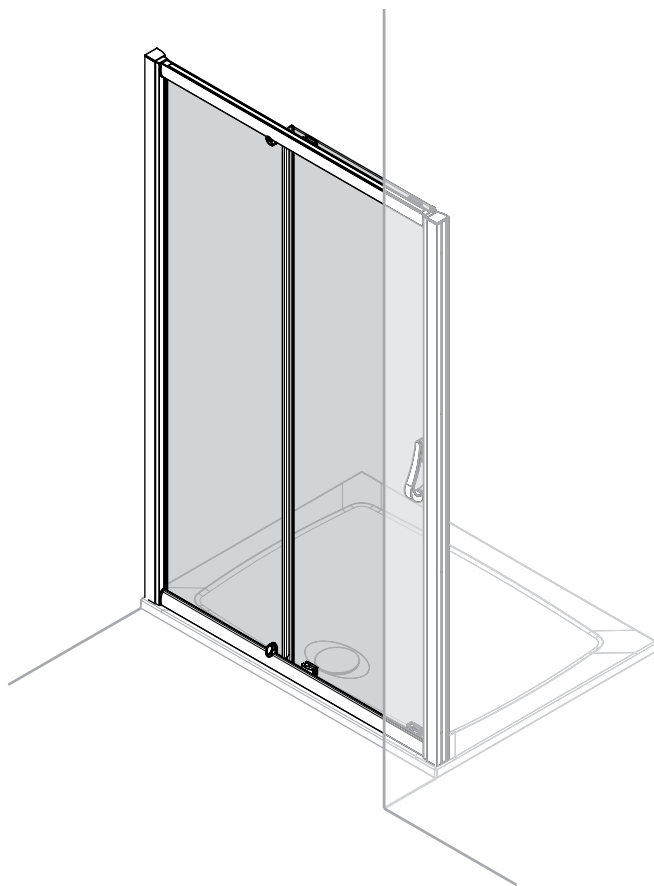

Before You Start

- Check that the tray has been installed correctly and that it is level (Fig. A), tiled down onto and sealed to the manufacturer's guidelines. **Please Note:** All product supplied without tray.
- Ensure the product is fitted to a non-porous surface ie. tiled. Check that the wall surface is flat.
- Unpack and check the product is complete and undamaged.
- Fixings are supplied for solid walls only. Ensure that the correct fixings are used for the wall type – if in doubt seek professional advice.
- Ensure the area is clean, dry and dust free.
- Read the instructions in full.
- Have the correct tools available, (as shown below, see 'Tools Required').
- It is recommended to situate the showerhead and door adjacent to each other in order to allow any water spray to be on the side panel or upstanding wall.

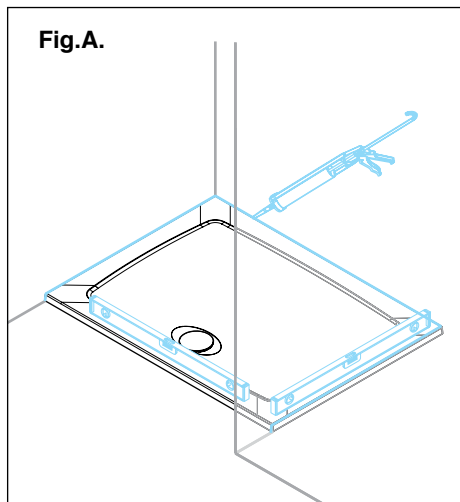



Safety

- Handle all glass with care - support on cardboard to avoid risk of breakage.
- This product is heavy and requires 2 people to carry and install it.
- When drilling walls check first for hidden pipes and cables.
- All glass is toughened – it cannot be reworked or replaced by ordinary glass.
- Use safety eyewear when drilling.
- Use safety eyewear when handling glass.
- Keep all small parts away from children.

Disclaimer

- Please notify the retailer immediately of any damage or faults. The manufacturer cannot be held responsible for any installation costs that may arise from damaged or faulty product being installed.
- Please dispose of all packaging with due regard to the environment.

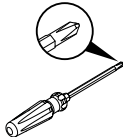
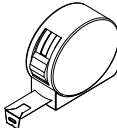
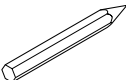
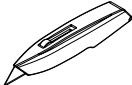
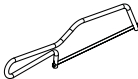
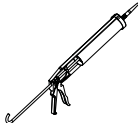
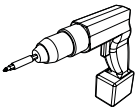
Tools Required (not supplied)

<p>Spirit Level</p> 	<p>Screwdriver</p> 	<p>Tape Measure</p> 	<p>Pencil</p> 	<p>Utility Knife</p> 
<p>Junior Hacksaw</p> 	<p>Silicone Gun & Sealant</p> 	<p>Power Drill</p> 	<p>Suitable Drill Bits</p>  <p>6mm dia. *</p>  <p>3mm dia. HSS</p>	<p>* Ensure drill bit used is suitable for wall surface</p>



Help Line: 0870 241 6131

Lines open: 8.30am - 5.00pm Monday to Friday
Standard National call charge rate from BT landlines

Parts & Fittings Supplied



Please notify the retailer immediately of any damage or faults. The manufacturer cannot be held responsible for any installation costs that may arise from a damaged or faulty product being installed.



Keep small parts away from children

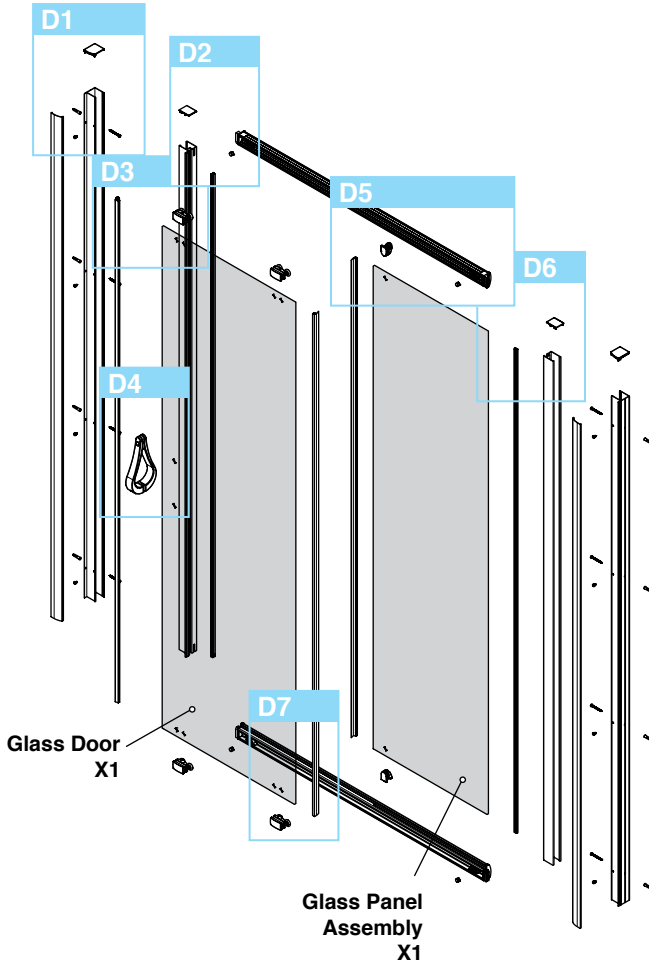

Allen Keys Supplied



3mm Allen Key

D1

*Left and right hand variants supplied

All components are supplied with Pivot Door Pack

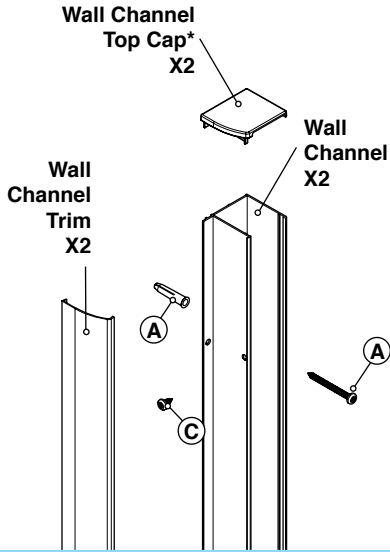

D2

** 1 no. cap supplied with side panel pack

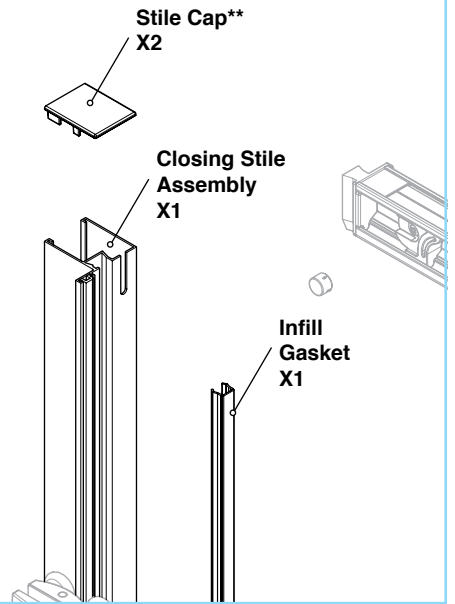

D3

Top Adjustable Bearing X2

Magnet Seal X1

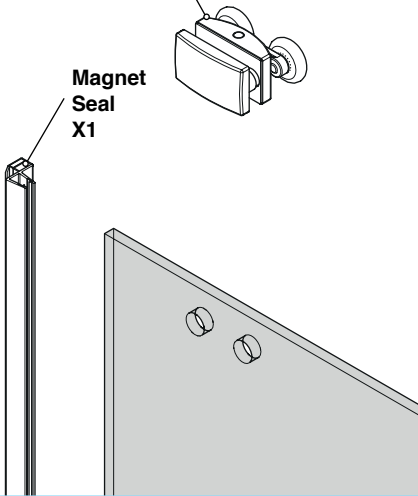

D4

Door Handle Assembly X1

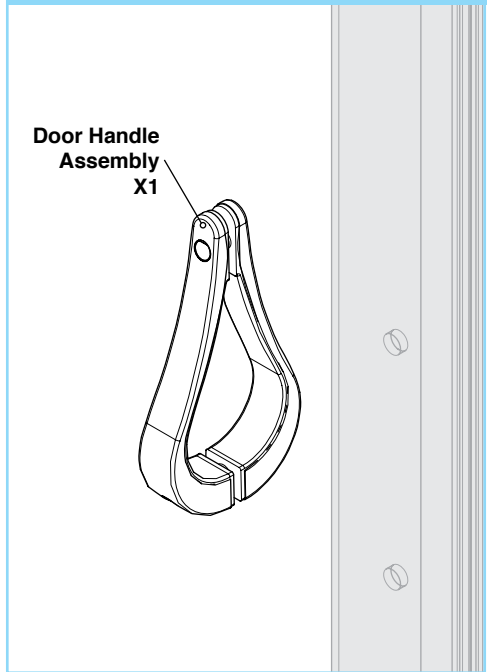

D5

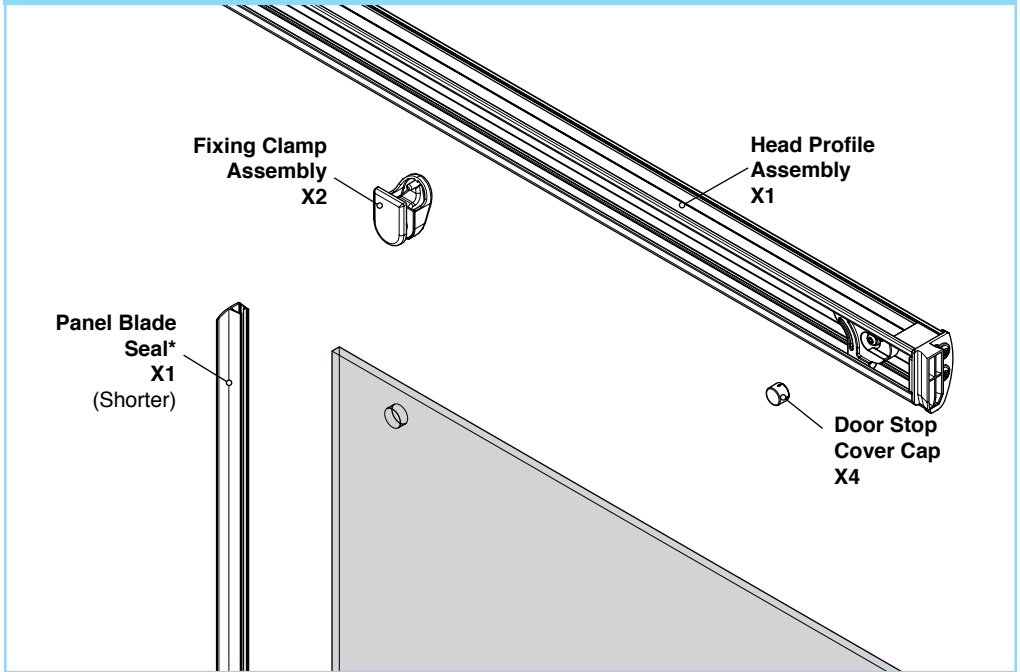

D6

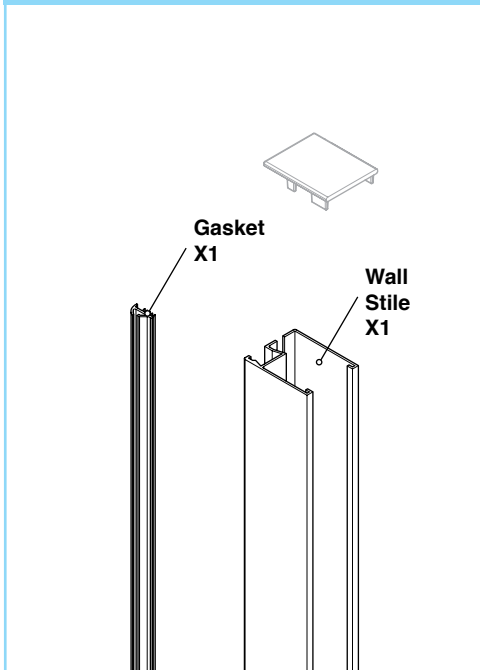

D7

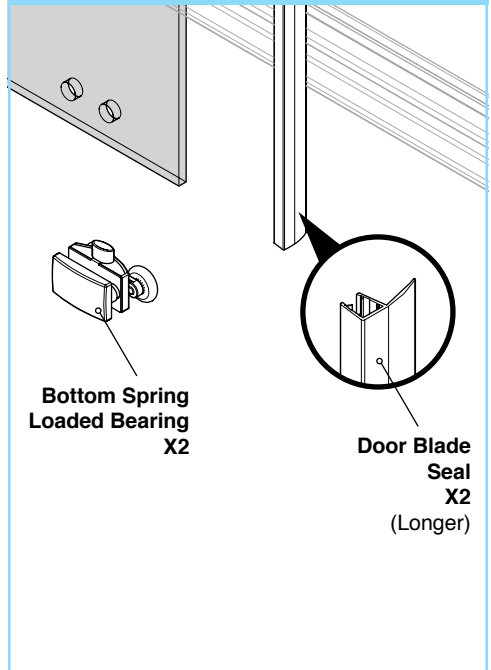

Loose Screws & Fittings Supplied

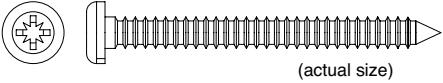
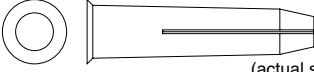
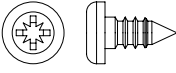
(A)	No.8 x 1 $\frac{3}{4}$ " Pan Head Pozi Screws	 (actual size)	Qty x8
(B)	Wall Plugs	 (actual size)	Qty x8
(C)	No.8 x $\frac{3}{8}$ " Pan Head Pozi Screws	 (actual size)	Qty x8

IMPORTANT NOTE:

This installation instruction is shown with a right hand entry to the enclosure (see below). If you would like to build your product as a variation of this (i.e. left hand entry) please mirror the details as necessary.

If in doubt please seek advise before commencing with the installation.

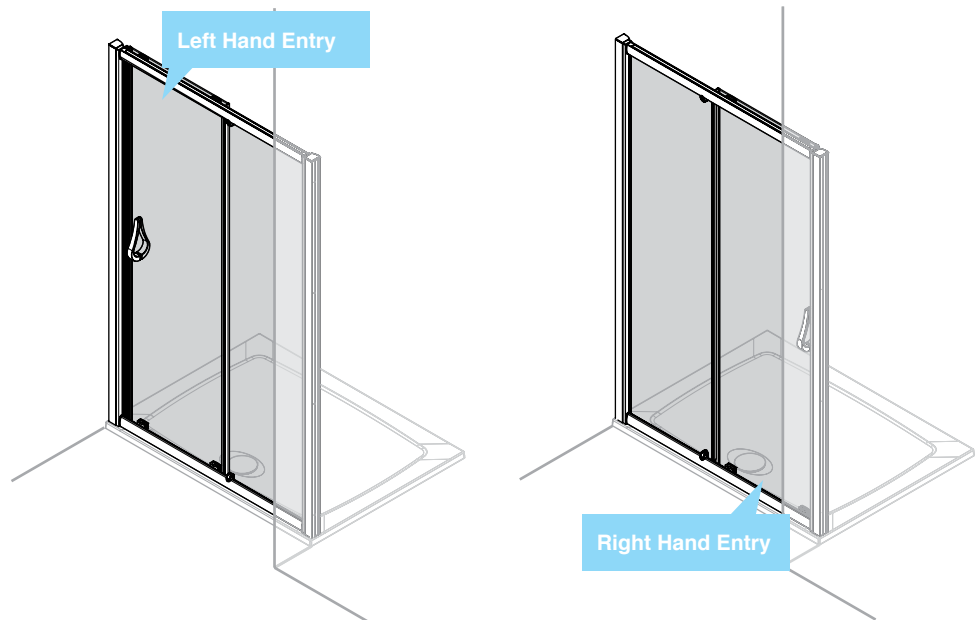

1.1



Slide Closing Stile Assembly into position onto Cill Profile Assembly*

! IMPORTANT NOTE:
Ensure that this assembly (1-10) is carried out on a flat / level surface.

! Ensure correct Closing Stile and Cill Assembly orientation.

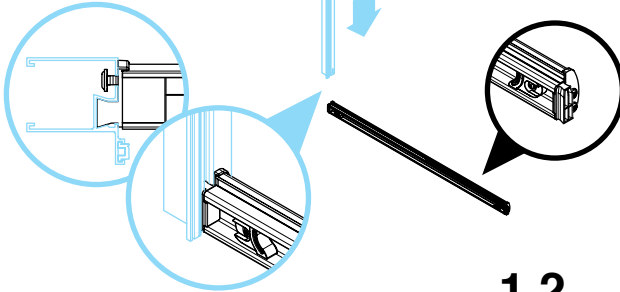

1.2

Slide Stile into position on Cill Assembly Profile as shown*

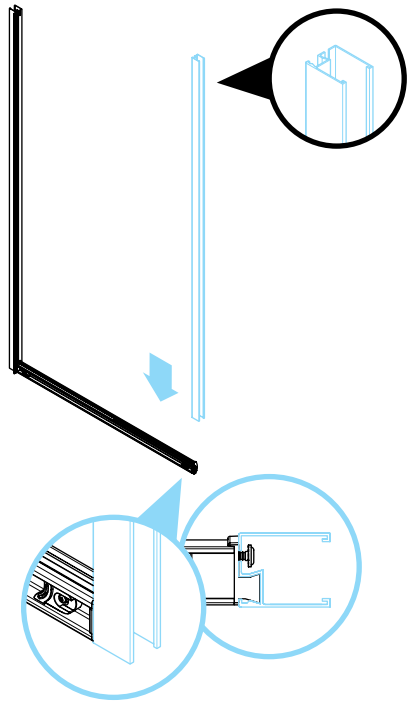
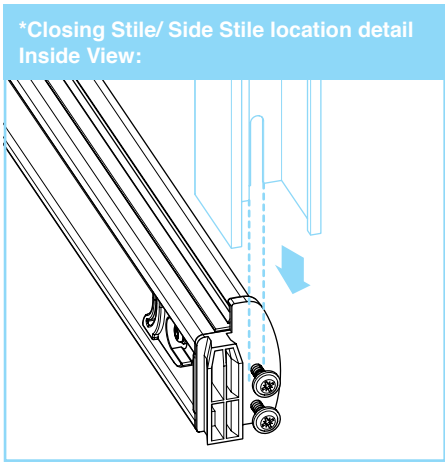

Inside View

2

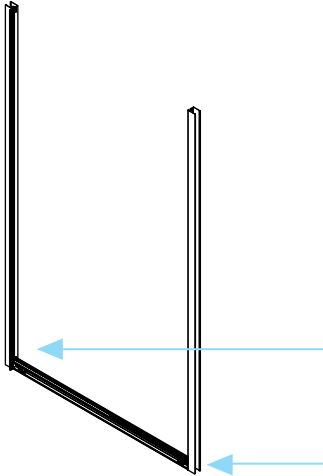

Inside View

i)

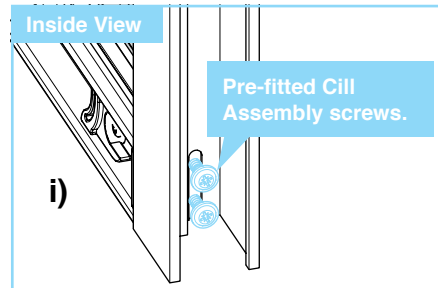

ii)

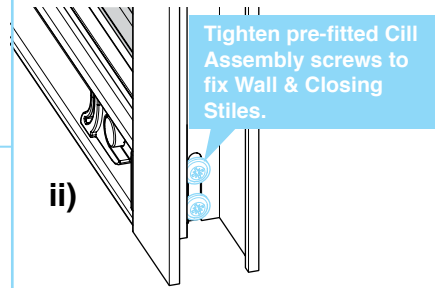

IMPORTANT NOTE:
Ensure product is assembled on a level surface/ floor and that the frame assembly is straight and level.

Inside View

3.1

Inside View, Alternative Angle

i)

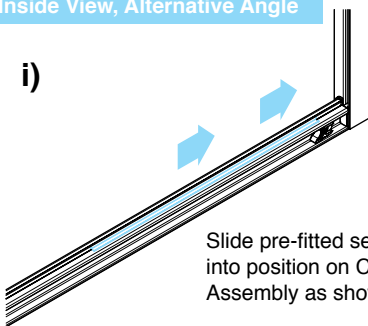

ii)

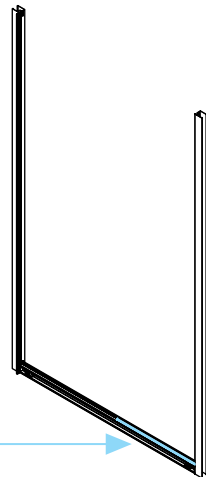
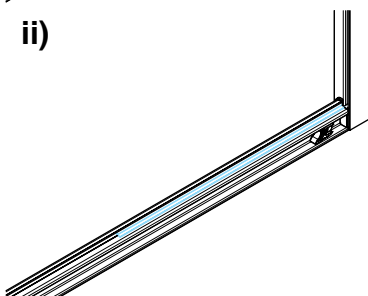

Ensure pre-fitted seal on Cill Profile Assembly is pushed up against Stile.

3.2

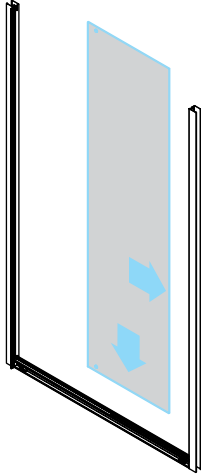

! Please take care when handling glass.

! Locate Glass Front Panel into Stile.

Inside View

4

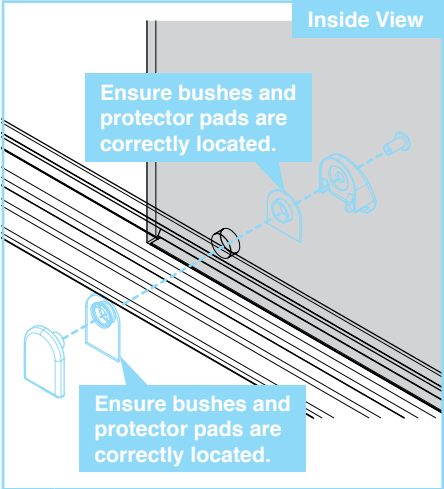

! Please Note: Fixing Brackets are supplied assembled. Using Allen key supplied, disassemble part and then re-assemble as shown. DO NOT overtighten.

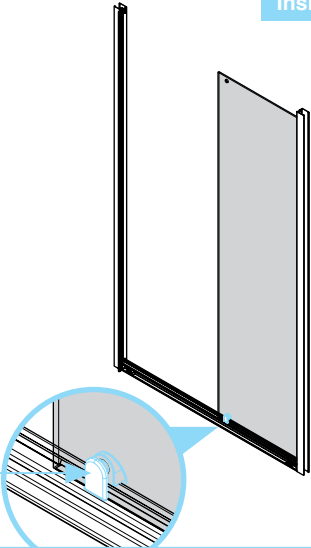

! DO NOT fit cover cap at this stage. Screw heads are on OUTSIDE of the enclosure.

Inside, Underside View

i)

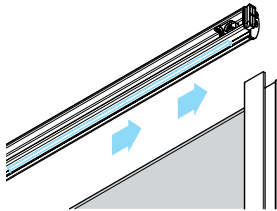

Slide pre-fitted seal into position on Head Assembly as shown

ii)

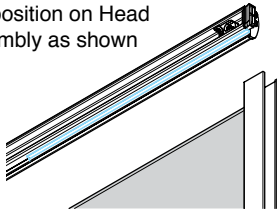

! Ensure pre-fitted seal on Head Profile Assembly is pushed up against Stile prior to slotting Head Profile Assembly into position.

5

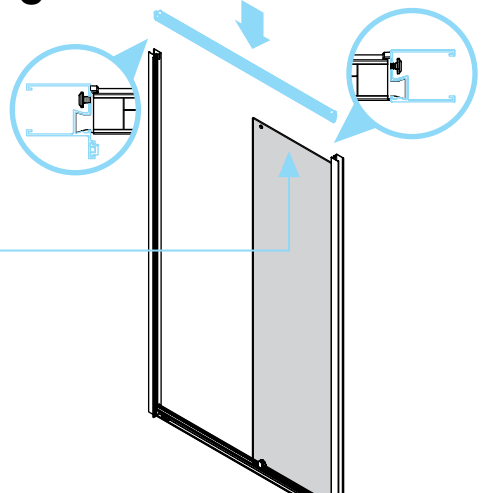

! Ensure that the Head Profile Assembly is push right down on top of glass panels.

Inside View

Ensure bushes and protector pads are correctly located.

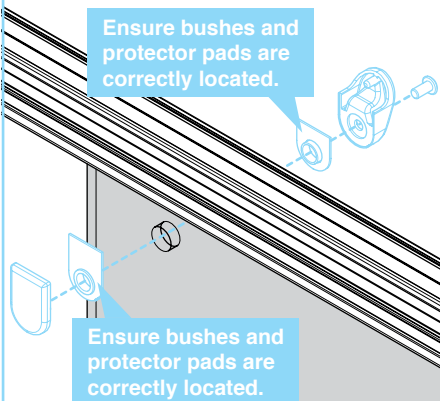

Ensure bushes and protector pads are correctly located.

! Please Note: Fixing Brackets are supplied assembled. Using Allen key supplied, disassemble part and then re-assemble as shown. DO NOT overtighten.

6

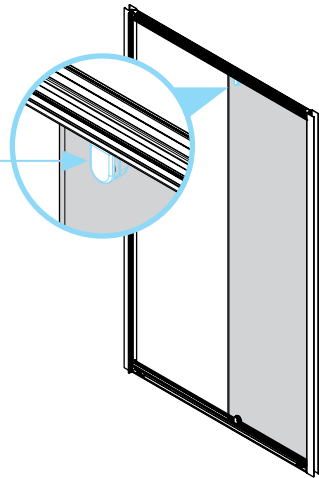

! DO NOT fit cover cap at this stage. Screw heads are on OUTSIDE of the enclosure.

Inside View

7

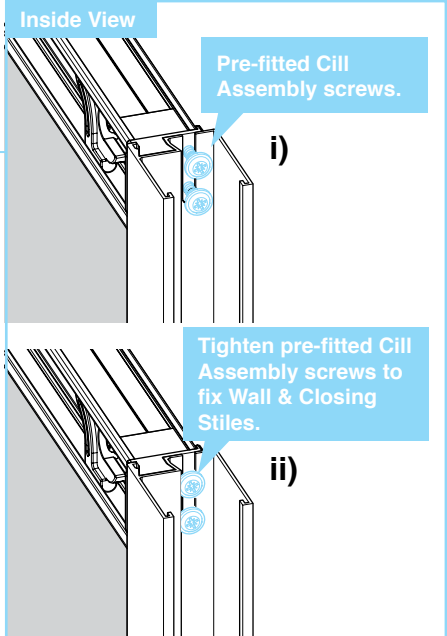
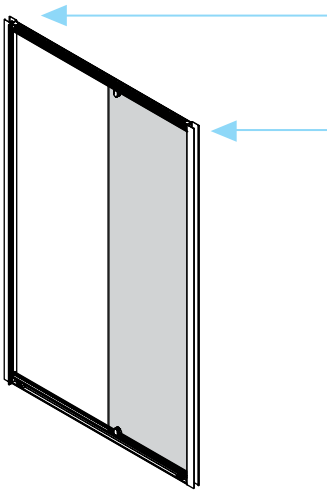

! IMPORTANT NOTE: Ensure that Head Assembly is located on top of glass prior to tightening pre-fitted screws.

Inside View

8

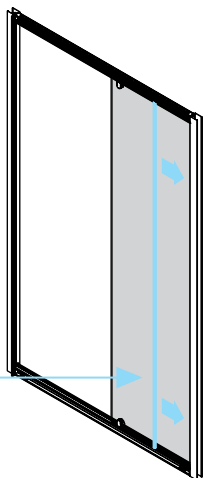
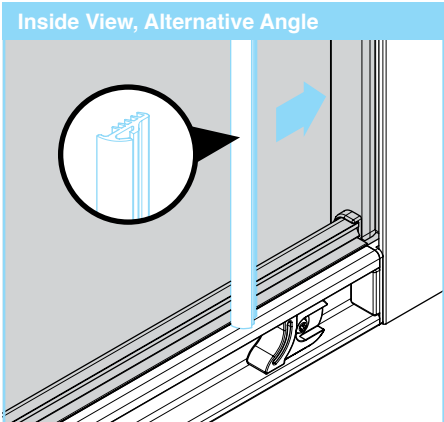

! Please Note: Gasket is supplied oversized, please trim Gasket to suit.

*** Tip:** Push fit Gasket, start at the bottom and work up.

! IMPORTANT NOTE: Ensure Gasket is down tight against bottom Cill Profile for a watertight seal.

Inside View

9

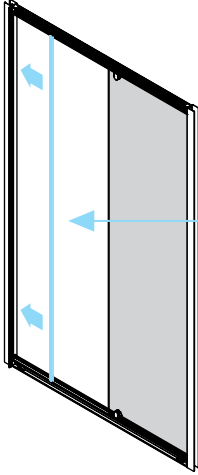

Inside View

Push fit Infill Gasket into Closing Stile Assembly

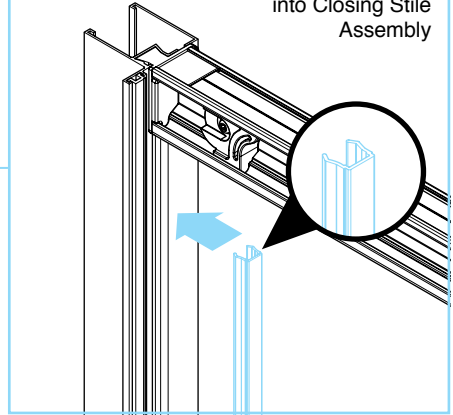

Inside View

10

Inside View

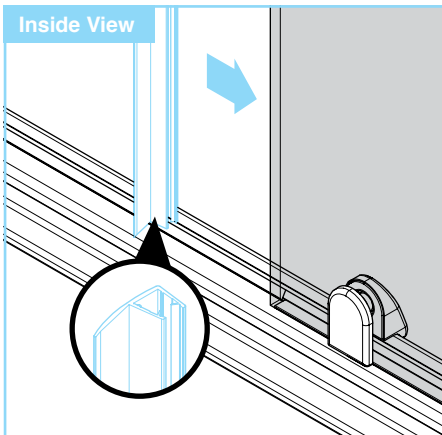

Tip:
To push fit Panel Blade Seal, start at the bottom and work up.

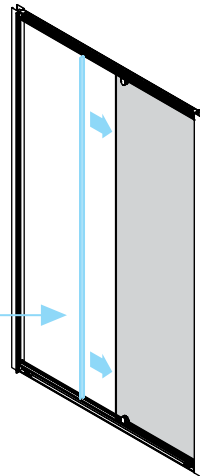

IMPORTANT NOTE: Ensure Panel Blade Seal is down tight against bottom Cill Profile.

11.1

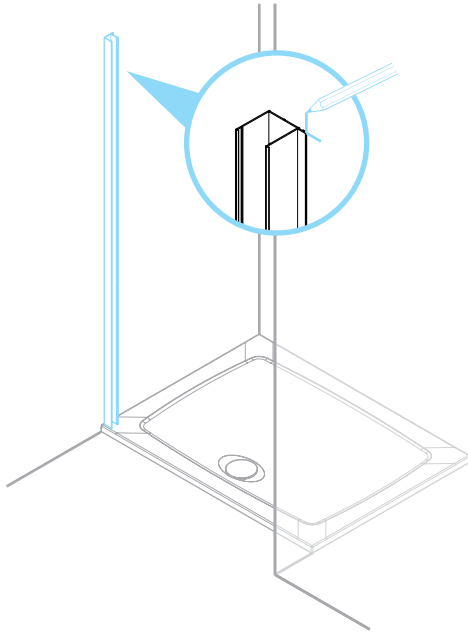

! Please Note:
Position one wall channel and mark. Ensure Wall Channel is level and in correct location to the tray. (If in doubt refer to illustration on step 12).

11.2

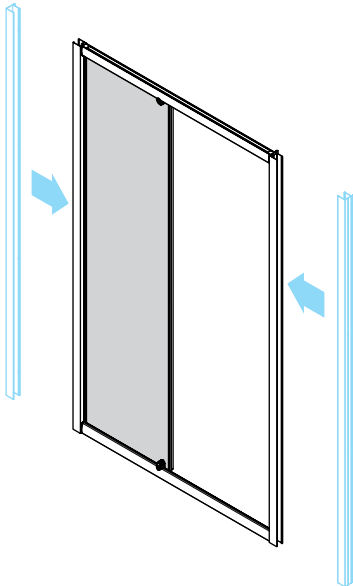

11.3

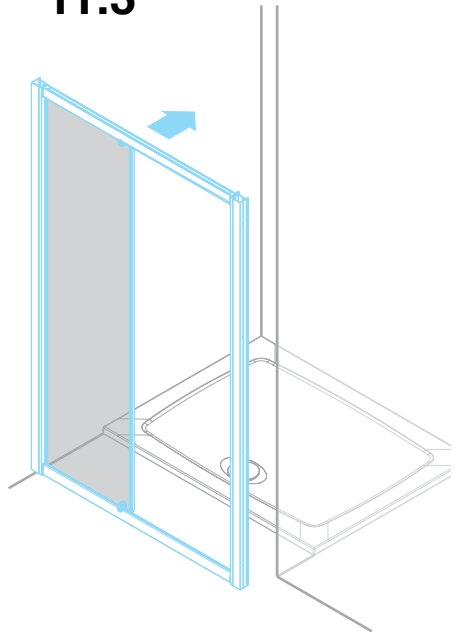

12



Ensure that the enclosure is positioned straight and is parallel with tray.

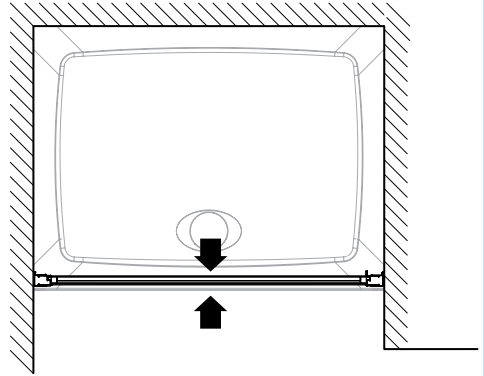

13

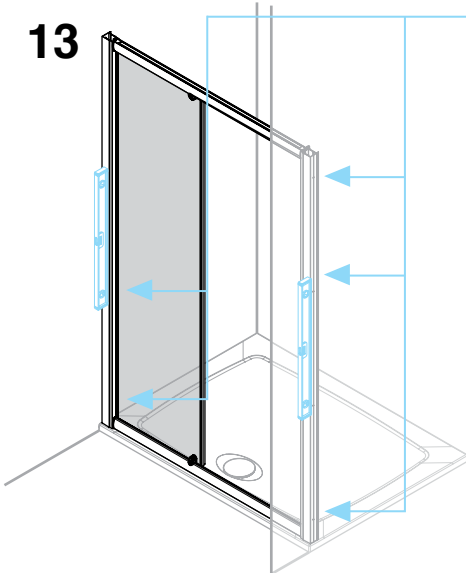

Wall plugs supplied are for solid walls only. Ensure correct wall plug for wall type is used. If in doubt seek professional advice.

IMPORTANT: Ensure Door is not twisted. For best results fix one side wall channel, and check door is level before continuing to fix second wall channel.

Inside View

13.1

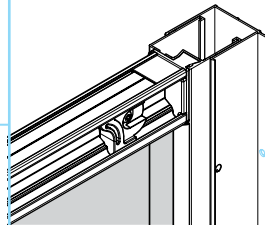

Mark position of pre-drilled Wall Channel fixing hole

13.2

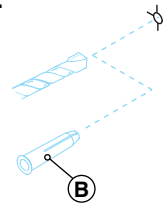

6mm dia. holes with drill bit suitable for wall surface

13.3

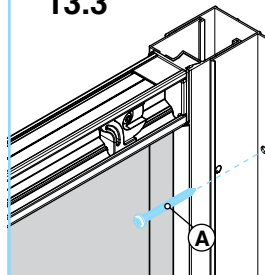

Fix through pre-drilled Wall Channel fixing hole

Inside View

14

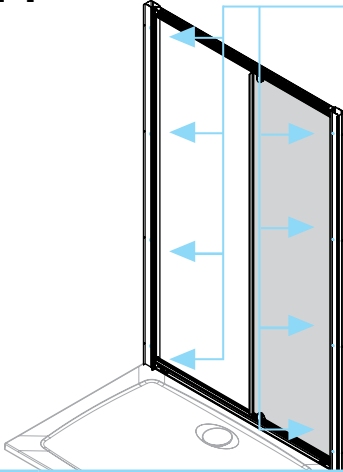

Ensure glass is positioned straight and is parallel with tray.

Inside View

*3mm dia. holes through pre-drilled holes using HSS drill bit

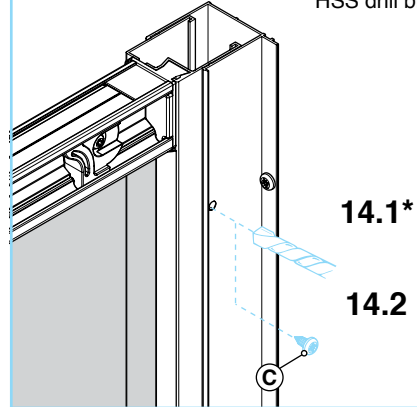

Tip: When inserting screws apply a small amount of oil to the screw thread to allow easier fixing.

Inside View

15



Please Note: Top Adjustable Bearings are supplied fully assembled. Disassemble part prior to fixing.



Please Note: Top adjustable Bearing and Bottom Spring Loaded Bearing variations. Use TOP ADJUSTABLE BEARING only.

Top Adjustable Bearing Fixing Preparation

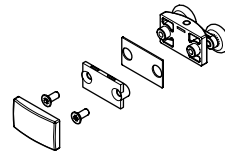

15.1

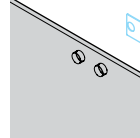

15.2

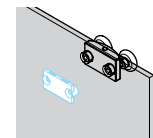

15.3

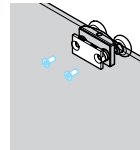

15.4

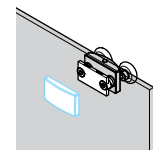

16



! Please Note: Bottom Spring Loaded Bearings are supplied fully assembled. Disassemble part prior to fixing.

! Please Note: Bottom Spring Loaded Bearing and Top adjustable Bearing variations. Use **BOTTOM SPRING LOADED BEARING** only.

Bottom Spring Loaded Bearing Fixing Prep.

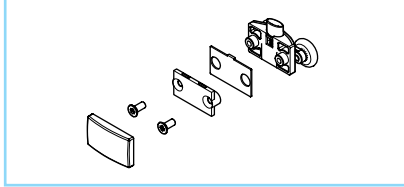

16.1

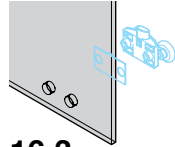

16.2

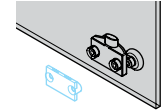

16.3

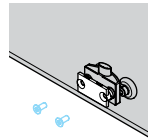

16.4

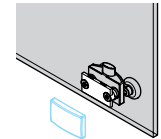

17

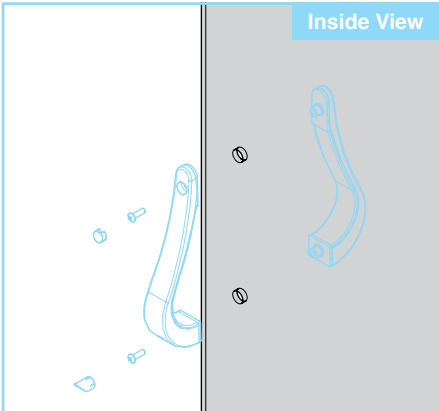

! Please Note: Door Handles are supplied assembled. Using Allen key supplied, disassemble part and then re-assemble as shown. Ensure all screw heads are on the enclosure interior. **DO NOT** overtighten.



18

Inside View

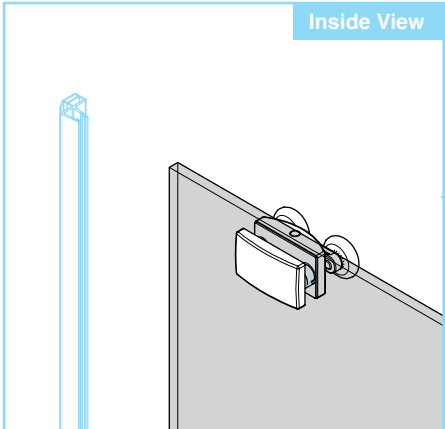

! Ensure Magnet Seal is fitted with magnet positioned on the **OUTSIDE** of the door, (as Shown).

***** Tip: Push fit Magnet Seal, start at the bottom and work up.

19

Inside View

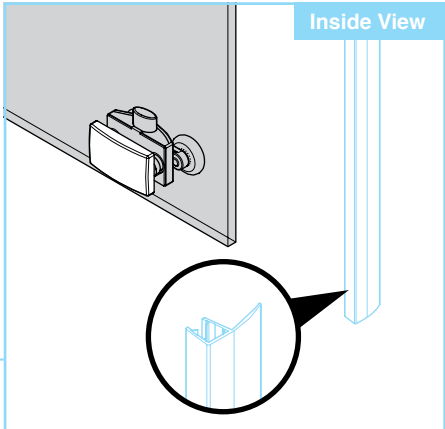
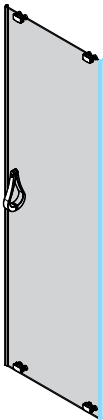

! Ensure Door Blade Seal is fitted with blade facing away from enclosure, (as Shown).

***** Tip: Push fit Door Blade Seal, start at the bottom and work up.

Inside View

20

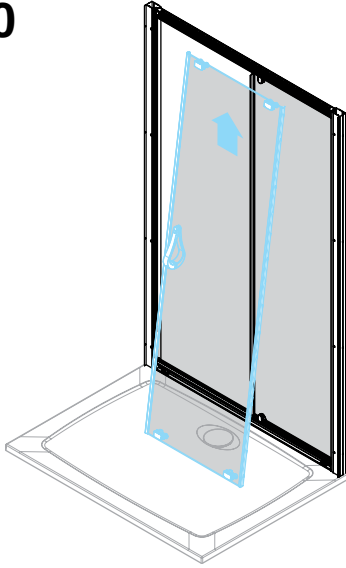

Tip:
Locate bearing wheels on the top rail first.

Inside View

21

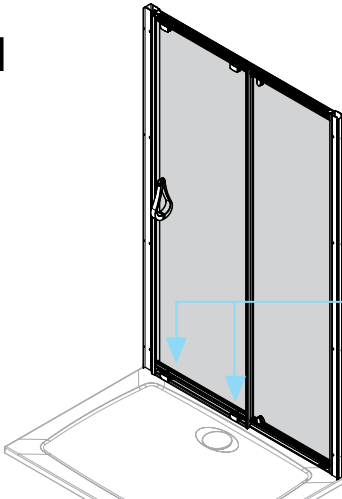

Tip:
Push button down and mount bearing wheels from the outside of the enclosure on to the rail, then release button to lock into place.

Inside View

21.1

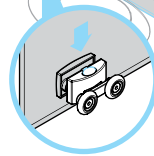

21.2

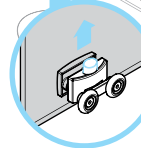

Inside View

22

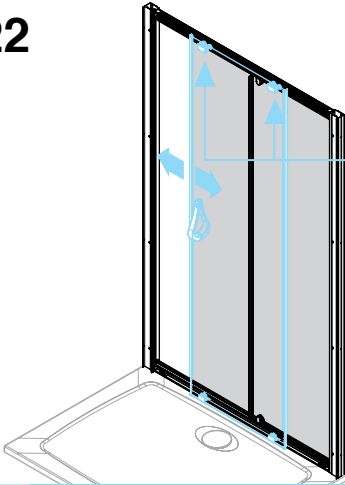

Tip:
When door is correctly located, door position can be adjusted up and down using Top Bearing adjustment screws (right).

Inside, Underside View

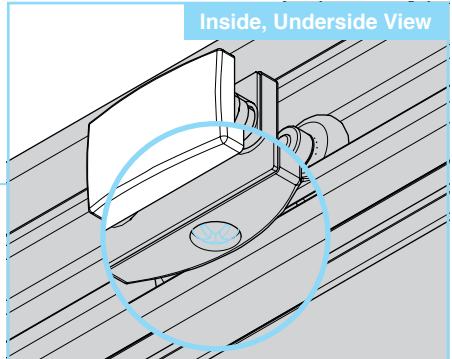

Using the adjustment in the Top Bearings, ensure that the Bottom Bearings are fully engaged into the bottom Cill Rail. Adjustment may also be used to ensure that the Door closes correctly against the Magnet Seal.



Ensure free movement of door. Adjust to suit.

Inside View

23

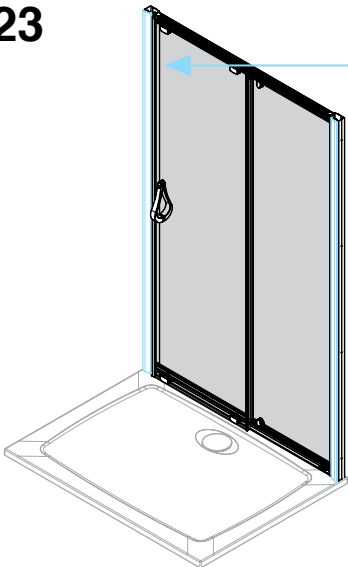

Inside View

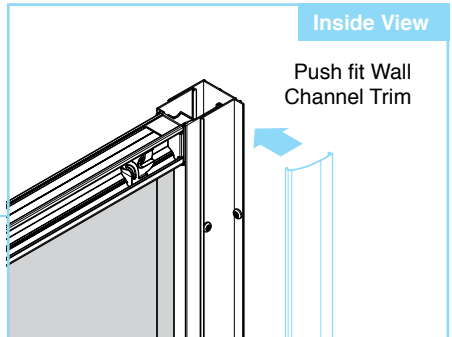

Push fit Wall Channel Trim

24

Inside View

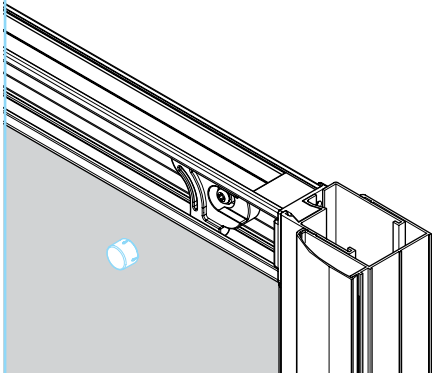

! Push fit Door Stop Cover Caps.

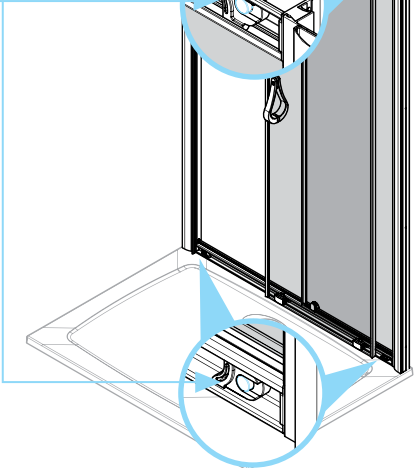

25

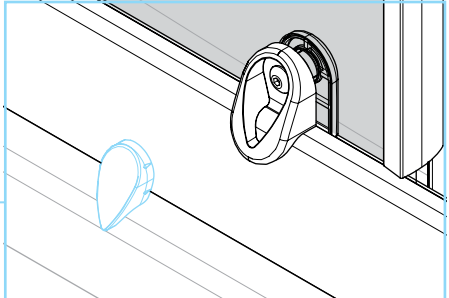
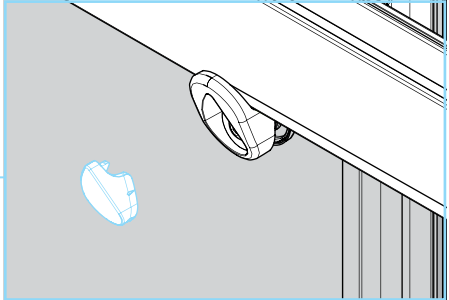
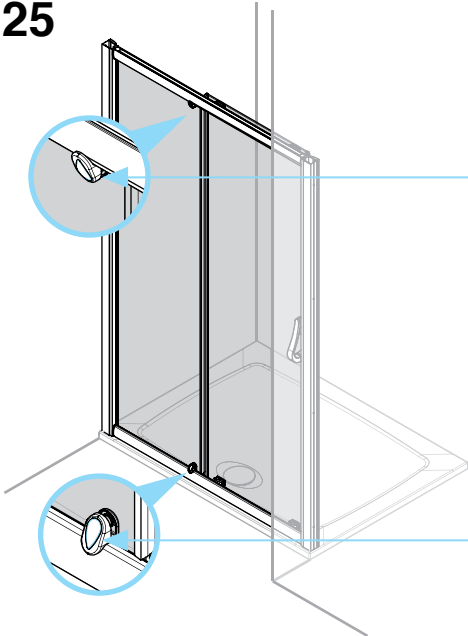

26

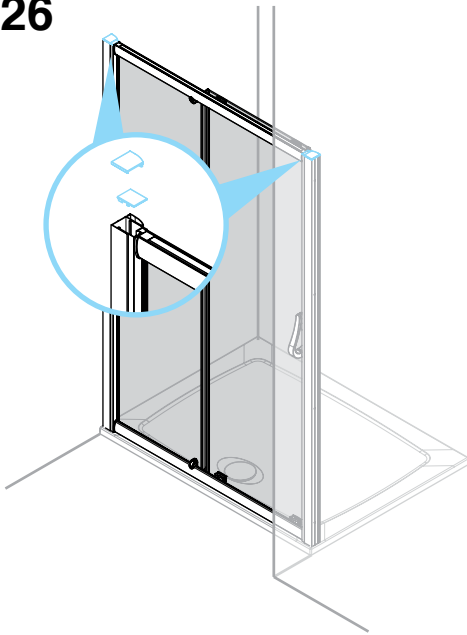

Push fit Wall Channel End Cap and Stile End Cap into position.



Take care not to let Wall Channel End Caps or Stile End Caps slip down the Wall Channel.



For best results, locate Stile Caps at the back edge first in the 'U' feature.

Inside View

27

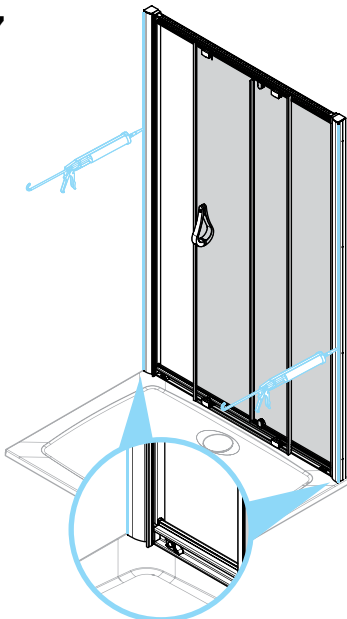

Apply Silicone Sealant, (not supplied) vertically between wall channel and wall only.

28

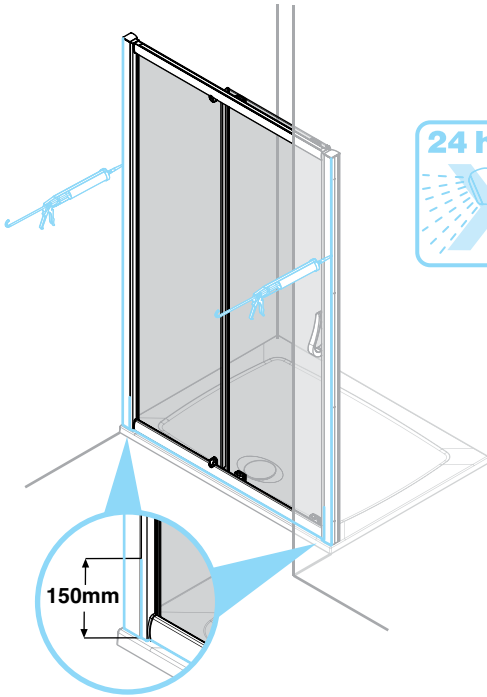

! Apply Silicone Sealant,
(not supplied).



***** Product Care:
Use a non-abrasive cleaner.
Water marks may be removed with
a proprietary limescale remover or
household vinegar.