



# **RADICABLE installation guide**

**July 2011 edition**



**technical hotline 1-855-5-RADIMO**

Please read through these instructions carefully before you begin installation.  
Check that you are aware of all the components required.

## CONTENTS

Product specifications and details	p.2
Selecting your floor heating cable kit	p.3
Important instructions prior to installing your heating cable	p.3-4
Selection of floor covering material	p.5
Notes on Thermal Insulation	p.5
Calculating the right length of cable	p.5
Defining cable spacing for your Radicable kit	p.5
OC spacing table	p.6
Floor sensor and temperature control	p.6
Electrical provisions	p.7
Wiring Diagrams	p.8-9
Preparing for your installation	p.10
Installing your Radimo heating system	p.10-11
Operating tips	p.11
Locating a fault in the cable	p.12-13
Control card & Warranty	p.14

## Product specifications and details

**Floor heating systems** are uniquely designed for total heating comfort in homes, offices, bathrooms, kitchens and other small or large areas where electric floor heating is the primary or secondary solution of choice. RADIMAT and RADICABLE floor heating systems come in cables sold loose on spools or woven/affixed to a mesh in a mat form (further herein referred to as Floor Heating Cable or Floor Heating Mat).

**The floor heating cable (RADICABLE series) is a twin conductor heating cable** with a 10ft power lead pre-attached on one end. It is pre-terminated on the other end (no power loop return). The heating cable consists of a resistance-heating element insulated with fluoropolymer (FP) with high dielectric strength and high temperature protection, making the heating cable totally safe. A metal ground sheath is provided to give additional mechanical strength and electrical grounding path. A final outer jacket of PV C is applied to make it sturdier and provide corrosion protection. The hot and cold junction or 'factory splice' is uniquely designed to make it 100% waterproof, safe and secure. The RADICABLE heating kits are available in a wide range of sizes and voltages to suit your requirements.

## Selecting your floor heating cable kit

Your choice of heating cable kit will depend on the area to cover and the application (heat output) desired. The following can be taken as a general guide (see chart with On Center Spacing for heat outputs):

- New floors in well-insulated buildings: 10 watts per sqft output
- Wooden floors : 10 watts per sqft
- Wet areas, bathrooms and kitchens: 14 watts per sqft

Please note the above values are meant as a general guide and that actual requirements will depend on insulation levels, floor construction, type of floor covering, ambient temperature. Consult a Radimo specialist for guidance.

	Area to be heated (sq ft)	Heaters	Watts	Amps	Length (ft)
120 volts	10	RADICABLE-10-120	120	1.0	40
	20	RADICABLE-20-120	240	2.0	80
	30	RADICABLE-30-120	360	3.0	120
	40	RADICABLE-40-120	480	4.0	160
	50	RADICABLE-50-120	600	5.0	200
	75	RADICABLE-75-120	900	7.5	300
240 volts	30	RADICABLE-30-240	360	1.5	120
	40	RADICABLE-40-240	480	2.0	160
	50	RADICABLE-50-240	600	2.5	200
	75	RADICABLE-75-240	900	3.8	300
	90	RADICABLE-90-240	1080	4.5	360
	110	RADICABLE-110-240	1320	5.5	440
	150	RADICABLE-150-240	1800	7.5	600
	190	RADICABLE-190-240	2380	9.9	600

## Important instructions prior to installing your heating cable

1. **The floor heating cable must not touch, cross or overlap itself** at any point. This could cause the cable to overheat, requiring replacement.
2. **The floor heating cable cannot be cut.**
3. Do not alter the cable length under any circumstances. This may cause overheating (shorten) resulting in damage to the cable, or resistance loss (lengthen).
4. **Take precautions to avoid damage to the heating cable** during installation. Avoid dropping sharp/heavy objects and protect the system from heavy foot traffic. Be careful when pouring mortar (thinset) and using a trowel over the heating cable. In the case of floor replacements, make sure that the old floors are removed before you lay the new cables.
5. The **Cables should be kept clear from other heat sources** such as heating ducts, radiators and fireplaces.
6. **Do not install the heating cable below 5F (-15 C) ambient temperature.**
7. **Thermal Insulation Boards** of adequate thickness and typical value of 0.027 can be installed below the under tile heating cable for added performance.
8. The **minimum bending radius** of the under tile heating cable while laying shall not be less than **1 inch (25mm)**.
9. The cold lead (10 feet long) can be cut/extended to suit the location of the electrical power connection box.
10. Place your thermostat sensor centered between two adjacent runs of cable. **Do not place the thermostat sensor closer than 1 inch from the heating cable or allow it to overlap any other cable.**
11. **The Maximum limit of the temperature setting on the thermostat should not exceed 86F (30C)**

## Important instructions prior to installing your heating cable (cont'd)

---

12. The RADICABLE heating system have two conductor wires (line & neutral at 120V and line and line at 240V) and a **ground wire** (metal sheath) that is to be connected to the electrical box or grounding from the supply side.
13. Make sure to select a kit of the desired **voltage. Typically, 120V, and for larger installations (>120sqft) 240V.**
14. **Check the continuity or resistance** of the Floor Heating Cable before and after installation. Resistance value shall match the product label or range within a tolerance of 5% to +10%.
15. Keep the power lead conduit separate from the sensor cable conduit
16. It is highly recommended to connect a fault detector (such as ThermoScout) during the installation to warn about accidental damage to the heating cable or lead wires.
17. The Heating Cable should **be connected to a Ground Fault Circuit Interrupter (GFCI )** or equivalent having a residual operating current not exceeding 30mA. Consult a qualified electrician. A GFCI is present in all RADSTAT models sold with the RADICABLE and RADIMAT kits.
18. In case the **GFCI** trips during normal operation and cannot be reset, contact technical support. No attempt should be made to re-energize the heating cable. Never bypass the GFCI. Consult a qualified electrician.
19. **Do not install** the RADICABLE under permanent fixtures, carpet or other non-masonry flooring. The cable should always be embedded in thinset, self-leveling Portland cement or similar.
20. **Allow** sufficient drying or curing period of the thinset and floor installation before powering up the heating cable.
21. It is wise to identify the supply or line cables supplying power to the heating cable. Keep one of the RADICABLE or RADIMAT UL specification labels on the cable or in the thermostat box, and one by the breaker on the main panel. Apply the warning label in a convenient location to show the room location where under tile heating cable is installed.
22. Use only listed conduit, fittings, and or other components. Electrical codes vary regionally and must be followed when selecting conduits and electrical boxes.
23. The heating system shall not extend beyond the room or area in which they originate.
24. Do not install the system near combustible material or provide ample spacing between the product and the combustible material.
25. The RADICABLE system should be installed by qualified personnel familiar with the construction and operation of the heating cable as detailed in this manual. Be mindful of the risks involved when dealing with live electrical wires. The wiring of the heating system should be performed by a licensed electrician.
26. The installation of the heating system shall be in accordance with the manufacturer's instructions as well as local and national electrical codes.
27. In Canada, the installation shall be made according to the provisions of section 62 of the Canadian Electrical Code, Part 1.
28. When use in wet locations, the installation shall be in accordance with the National Electric Code, NFPA-70 and CAN/CSA-C221, Canadian Electrical Code, Part I (CEC) and that final acceptance is to be made in the field by the Authority Having Jurisdiction (AHJ).

### **WARNING : RISK OF ELECTRIC SHOCK AND FIRE**

**DAMAGE TO SUPPLY LINES OR INSULATION MAY OCCUR IF POWER CABLES ARE ROUTED LESS THAN 2 INCHES (51 mm) FROM THIS HEATING PRODUCT. REFER TO THE INSTALLATION INSTRUCTIONS FOR ADVISE ON PROPER ROUTING OF ELECTRICAL SUPPLY LINES.**

## Selection of floor covering material

The type and thickness of floor covering materials used with this product must not exceed a thermal insulation or "R" value of 1.

Example of "R" Values : CARPET 1/4" THICK = R 1.0

CERAMIC TILE 1/4" THICK = R 0.15

LAMINATE FLOORING = R 0.675

PLYWOOD 1/2" THICK = R 0.63

NATURAL STONE (GRANITE, LIMESTONE, MARBLE, SANDSTONE) 1" thick = 0.38-0.14

WOOD FLOORING = R 0.80

## Notes on thermal insulation

The insulation levels of a floor will affect both the performance & running costs of your heating system. An electric radiant heating system without thermal insulation and installed on subfloors with high levels of heatloss (slab on grade) can take up to 5 hours to heat a room. Systems installed with thermal insulation take less than one hour.

The thermal insulation reflects the heat upwards into the floor tile instead of allowing the heat to penetrate into the sub floor and thereby keeps the floor warmer for a longer time. In cases where the heating cable is being installed over large areas, insulation boards will greatly reduce warm-up times & running costs.

Insulation materials can take many forms ranging from cork-based underlayments to polystyrene boards. These products are applied to the subfloor with screws, tile adhesive, glue, or a combination of the above. The insulation thickness recommended will vary depending on the subfloor type and the results desired in the room. Contact your RADIMO specialist for further advice.

While most plywood and second-floor installations present low levels of heatloss, concrete slabs and basements call for a layer of insulation prior to installing the heating cables.

Adding insulation on top of the concrete slab and underneath the floor heating system will allow a greater percentage of heat generated to transfer to the flooring surface. Certain types of insulation such as 6 mm thick cork or 6 mm to 10 mm of Expanded Polystyrene (EPS) are the most common applications.

## Calculating the right length of cable

Once you have identified the area to be heated (excluding fixed furniture, tubs and cabinetry), total the square footage and select the right wattage output for your project based on the insulation levels and primary or secondary heating output desired. Multiply the heated area and the watt density to obtain the total wattage required in the room. Choose the nearest suitable RADIMO kit from the available range.

## Defining cable spacing for your radicable kit

In order to fit the under tile heating cable evenly in the room, it is important to plan the spacing between the cables or "On Center Spacing". Use the guide below to define the ideal OCS for your RADICABLE kit:

$$\frac{\text{Net Heating area} \times 12}{\text{Length of Cable(s) in feet}} \quad \text{or} \quad \frac{12 \times \text{Cable (w/ft)}}{\text{Areas loading (w/ft}^2\text{)}}$$

Each cable kit length is identified in the product selection guide. When needed, you can combine multiple kits in a single room. Make sure to route all power leads to the control device and to never "daisy chain" the heating systems. Once you have your spacing defined you are ready to begin laying out the system. Some installers recommend that you cut out a measuring template out of paper or cardboard to guide you with the OCS. Another method is to mark on the floors the unheated areas close to walls and fixtures as well as tagging your cable spacing at both ends of the room as a guide.

Note: Spacing should not be less than 2 inches and wattage output should not be more than 15 w/ft<sup>2</sup>

## OC spacing table

Area loading	160W/m <sup>2</sup> (15W/sqf)	130W/m <sup>2</sup> (12w/sqf)	100W/m <sup>2</sup> (9.3w/sqf)	80W/m <sup>2</sup> (7.5w/sqf)
Cable rating	OC distance (inches)			
13 w/m (3.96 w/ft)	3.2	4.0	5.1	6.3
984 w/m (3w/ft)	2.4	3.0	3.9	4.8
8.2 w/m (2.5 w/ft)	2.0	2.5	3.22	4.0

## Floor sensor & temperature control

Only UL listed Programmable thermostats with floor sensor specifically designed floor heating system should be used with the RADIMO kits. The floor sensor is usually supplied with the control device and is typically 10 feet in length. The floor sensor tip (thicker, measuring edge) should be located on center between two adjacent runs of heating cable. Use a separate conduit for the floor sensor if your local code requires conduits. The sensor cable shall be routed to the thermostat located in the wall at suitable operating height. Do not allow any other cable to overlap with the sensor cable.



Thermostats

The maximum temperature setting on thermostat should not exceed 86°F (30°C). The lead wire or lead wires (when using multiple kits) should be routed to an electrical box and directly connected to the thermostat or control switch. When necessary, the lead wire connections can be made in a separate, code-compliant junction box.

**NOTE :** 240V wires are black and red. 120V wires are Yellow and Black. Connect grou wires to the house ground or if unavailable, to the electrical box or conduit. The to Amp load of heating system must not exceed the thermostat's 15 Amp limit. Use appropriately rated contactor or relay control when connecting loads exceeding amps. Please carefully consult the thermostat instructions for exact loads, connectic and wiring.



Floor sensor

## Electrical provisions

---

The heating cable wiring shall be in accordance with the local and national codes. A list of controls and accessories required for proper system installation is featured below:

- » A floor-sensing temperature controller, mounted in code-complying electrical box
- » A GFCI breaker if ground fault protection is not provided in the control device. All RADIMO controls, RAD-STAT-PRO and RAD-STAT-MAN have a built-in protection allowing a standard breaker to be used.

The heating system has to be connected to a main switch or breaker for complete disconnection at the panel on all poles (minimum 012 inches disc. Distance).

The location of the Thermostat / connection box shall be flushed in the wall at about 4' in height for easy access and setting. The Floor sensor cable and the under tile heating cable cold leads shall be routed to the thermostat / power connection box in separate conduits.

If the total amperage load of the selected system is equal or less than 15 amps, it can be connected directly to the control device as set forth on the device's wiring instructions. In case the system carries a total load higher than 15 Amps, consult a RADIMO specialist and qualified electrician to advise in the use of contactor panels or relay switches. Another option is to break down the heating system in zones on separate thermostats.

A GFCI (Ground Fault Circuit Interrupter) breaker or GFCI equipped controller must be used with the system. The Circuit Interrupter must have a rated residual operating current not exceeding 30mA to protect against ground leakage and electrical shorts.

The maximum wattage load is 3,600 watts at 240V on a 15A GFCI equipped controller. Please consult a qualified electrician for selecting a suitable GFCI protection for floor heating system exceeding 3,600 watts/240V or 1,800 watts/120V.

# Wiring diagrams - 120V

## Typical Wiring for a Thermostat GFCI Control to an Existing Breaker:

Dedicated 110 – 120V  
Circuit as per NEC

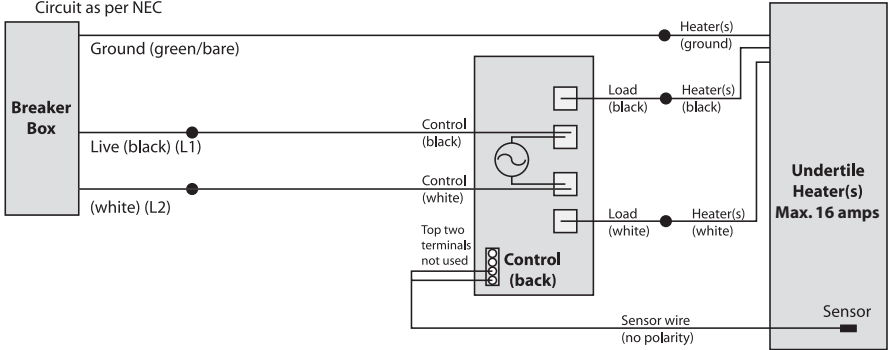

**NOTE:** All electrical work must be performed by a qualified electrician in accordance with local building & electrical codes and the *National Electrical Code (NEC)*, especially Article 424, Part V of the NEC, ANSINFPFA 70.

**NOTE:** Wiring for L1 is usually black (live) and wiring for L2 is usually white (as used for Neutral).

## Typical Wiring for a Thermostat Control and Contactor to an Existing Breaker:

Dedicated 110 – 120V  
Circuit as per NEC

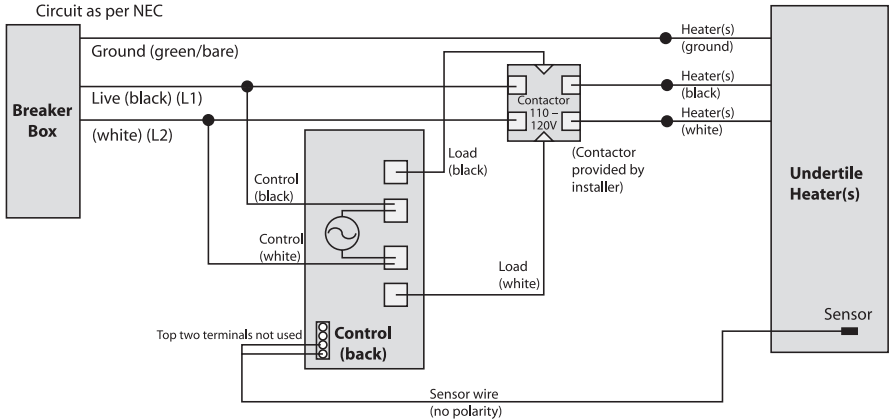

**NOTE:** All electrical work must be performed by a qualified electrician in accordance with local building & electrical codes and the *National Electrical Code (NEC)*, especially Article 424, Part V of the NEC, ANSINFPFA 70.

**NOTE:** Wiring for L1 is usually black (live) and wiring for L2 is usually white (as used for Neutral).



# Wiring diagrams - 240V

## Typical Wiring for a Thermostat GFCI Control to an Existing Breaker:

Dedicated 240V  
Circuit as per NEC

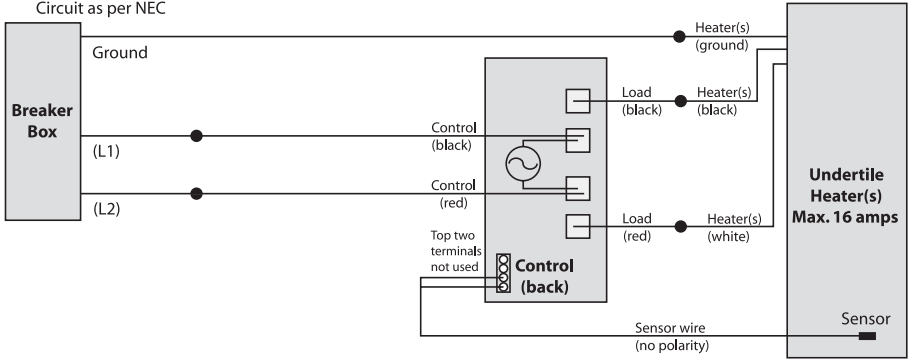

**NOTE:** All electrical work must be performed by a qualified electrician in accordance with local building & electrical codes and the *National Electrical Code* (NEC), especially Article 424, Part V of the NEC, ANSI/NFPA 70.

## Typical Wiring for a Thermostat Control and Contactor to an Existing Breaker:

Dedicated 240V  
Circuit as per NEC

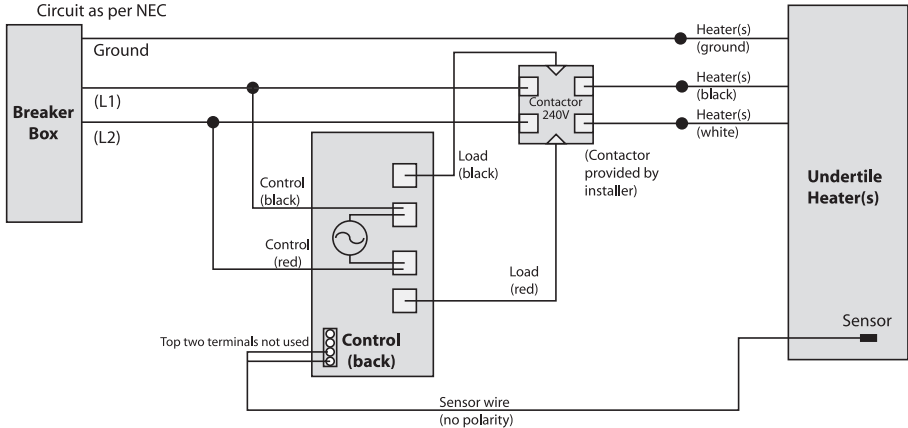

**NOTE:** All electrical work must be performed by a qualified electrician in accordance with local building & electrical codes and the *National Electrical Code* (NEC), especially Article 424, Part V of the NEC, ANSI/NFPA 70.

## Preparing for your installation

1. Prepare a floor plan of the area to be heated and plan the approximate start and end of the heating cable.
2. Identify the location of the power supply or electrical box to host the control device.
3. Mark the layout of the heating cable on the floor plan and calculate your cable spacing (see above for guidance). You can use the space provided at the end of this manual. Marking the heating cable layout on a floor plan makes it easier to trace back the heating cable for troubleshooting purposes. Keep such layout filed after installation.
4. Select the best-fitting RADIMO kit and verify the square footage and total wattage loads based on your project needs.
5. Complete a visual inspection of the heating system in the box and ensure it shows no obvious sign of damage.
6. Check the voltage and wattage on the label and use an Ohm-meter or Multimeter to check the resistance readings. Confirm that they match the listed specifications.

A tolerance of -5% to +10% is allowed. Record it on the control card provided at the end of this instruction manual. Check the insulation resistance between line core to ground sheath with a megger, or alternatively, ensure that the resistance between the conductor wires and the ground wire is open (your reader will read "open", infinity, 0 or 1).

7. Preparing the flooring surface is very important. The floor must be completely swept of all debris including all nails, staples, sharp metallic objects, protruding wood, construction debris and damaged/defective cables. Visually check that there are no objects on the floor that might damage the under tile heating cable.
8. Ensure that the insulation board of required thickness is installed on the sub floor when advisable. Use suitable glue, cement based adhesive or screws to apply the boards to the subfloor.
9. You are now ready to lay the floor heating system as planned in the initial stages of this section.

## Installing your radimo heating system

1. Mark the layout of the Under Tile Heating Cable on the floor.
2. Start your cable installation at the location of the power connection box
3. Roll out the Under Tile Heating Cable and secure the cable to the floor using the provided cable straps. When necessary, use tape to hold the cable down.
4. The heating cable should be kept about 3 inches away from the walls and perimeter.
5. Zig-zag the heating cable throughout the room to cover the desired heating area. Refer page number 6 for On Center Spacing calculations.
6. Tape the pre-terminated cable end to the floor
7. Back at the start of the installation, route the power leads through a conduit from the floor to the connection box. If using multiple cables, route all power leads through one or multiple conduits from the floor to the connection box in the wall.
8. Now that you've completed the cable layout, check the Insulation Resistance and Conductor resistance values again to ensure no damage was caused to the cable thus far. Check that the readings are consistent with the pre-installation values. Record values in the control card.

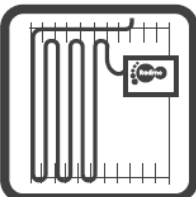
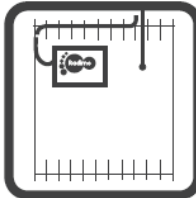
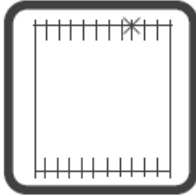

## Preparing for your installation (cont'd)

9. You can now start laying the tiles using a suitable cement-based adhesive or thinset of minimum 3/16" thickness. The thinset used for tile applications is typically applied with a 1/4" notched trowel. Check with your flooring supplier for advice on thinset selection and trowel usage. The size and thickness of your tiles will determine the proper notch trowel. For installation other than tile or stone floors, make sure to cover the complete heating system with a "skim coat" of minimum 3/16" thickness. A flat trowel or self-adhesive compound can be used to that effect.
10. When laying tile and stone, ensure no air gaps are created under the flooring. Apply proper pressure during flooring installation especially when using a "back-buttering" technique.
11. Ensure that the entire heating cable, factory splice and thermostat sensor are embedded in the cement or thinset mortar. The choice and application of building materials should always be in accordance with the manufacturer's instructions.
12. Verify curing times for the thinset mortar or cement compound and do not power the heating cables until that drying period is complete. The levels of moisture, heat and ventilation the room is exposed to will affect the curing time.
13. Finally, check the resistance value on the cables and verify that they are consistent with the prior recordings. Record values in the control card.



**REMINDER : RADIMO heating systems must always be embedded in thinset mortar or Portland cement mix. This is valid for all flooring installations including wood floors.**

## operating tips

1. When first energized, the under tile heating cables may take up to 3 hours to fully warm your floor.
2. Energy consumption will vary depending on thermostat settings. For a lower energy consumption, reduce temperature setting in the thermostat or duration of heating periods.
3. Energy consumption can be minimized by turning the system completely OFF when floor heat is not required (as opposed to off peak idling => see programmable thermostat), but warm-up times can be longer upon reactivating the system. Use the OFF function when leaving the room or house for extended periods.
4. All RADIMO controls provide for a "set-back" option allowing to reduce the heat-up time to less than 1 hour by idling at a reduced temperature during off-peak period(s). Consult your thermostat manual for programming.
5. Avoid placing thick mats, rugs or flat-base furniture on your heated floor, especially in the area where the thermostat sensor is located. These restrict the transfer of heat away from the cables and result in the floor area beneath them being warmer than other areas.
6. Avoid mats with rubber or vinyl type backing, as these may dry out and decompose with extended exposure to heat.

### Illustration of how lay UNDE RTILE HEATING CABLES to suit your floor plan

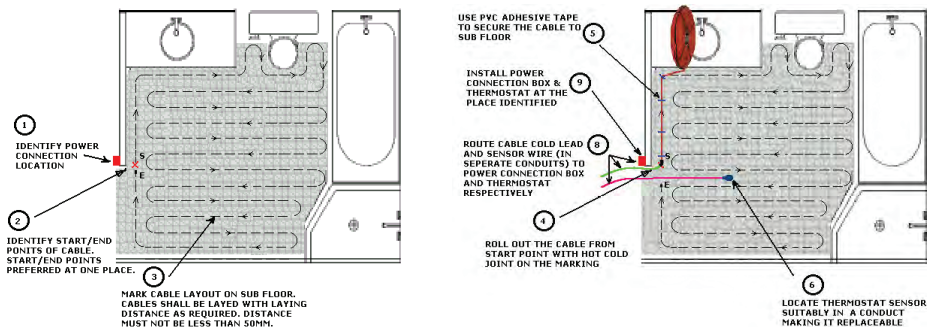

## Locating a fault in the cable

---

During the installation of cable and flooring materials, consider the use of a resistance tester in order to be instantly warned of any damage to the cable.

### Electrical fault-finding

Once the system has been turned off and the main power source has been disconnected, have a qualified person:

1. Ensure all wires have been connected as per the wiring diagrams.
2. Make sure that when using multiple systems, they have been wired in parallel and not in series. All leads must route back to the control device.
3. Confirm that the control devices are supplied with the correct voltage.

Using a digital Ohm meter, test the Ohm resistance level of each heating cable against the reading as provided on the manufacturer product label.

If your reading is not within the +10% / 5% range from the original reading, the Cable may be damaged in some way. Check that the resistance reading between the core conductors and the ground sheathing is open. Any level of reading may indicate a lead to ground.

Check with your RADIMO representative and consult a certified electrician to locate the fault or break in the cable.

### Locating a break or a short

If your installation is complete and that all wiring connections have been verified to be correct (including grounding of the system), check the sensor wire for proper Ohms reading. If you suspect the system is still not working, you need to determine if there is a break or a short under the floor.

### Checking for breaks

The Ohm resistance of each cable should be measured. Make sure the probes of the Ohm meter do not touch the ground wire at either of the line wire. Make sure you do not touch either of the probe ends (from your meter), or the meter will be reading your internal body resistance.

Set your Ohm meter on the proper scale (0-to-200 or lowest available for Heating Cable, or 0-to-20,000 for the sensor wire).

Your Ohm resistance readings should come within +10% / 5% of the nominal resistance as indicated by the manufacturer. If your Ohm reading is within +10% / 5% of what it should be, there is no break. However you should check for an electrical short by measuring the resistance between the conductors and the ground sheath.

If your Ohm reading is lower than recommended readings from core-to-core but there is indeed some level of continuity, double check your Ohm meter and your batteries. If these are good, there is a possibility that you have several electrical shorts.

If you have absolutely no reading (= infinity on your meter), and you are sure you adjusted the setting of the Ohm meter to the correct reading range (0-to-200 for the Heating Cable, or 0-to-20,000 for the sensor wire), then you have a complete break (=in the conductor cable. Contact RADIMO for guidance on how to locate a break under the floor in order to proceed to repair the damaged cable section.

### Checking for electrical short

In some rare occasions an installation may have suffered from a high pressure point that broke the insulation between the core conductor and the ground sheath. Such opening in the insulation layer can create an electrical short, even though the resistance reading between core conductors is normal and does not indicate any circuit break.

## Locating a fault in the cable (cont'd)

---

In these rare occasions a continuity test will show continuity between the one or both line conductors and the ground wire. Ideally, there should be no continuity (= "infinite" or "open" resistance reading) between the line conductor and earth.

If your instrument reveals continuity between the line conductor and the ground sheathing, there is a short in the circuit.

There are three ways to locate breaks or electrical shorts with underground fault detectors.

1. A break can be found with a "thumper", an impulse-generating device that generates a sound at the break point. The thumper includes a stethoscope to locate the exact placement of the break under the floor.
2. A short can be found with a "time delay reflectometer" or TDR, which will measure the distance of the wire between the tester and the short point.
3. Breaks and shorts may in some cases generate enough heat that they can be found with infrared cameras scanned over the floor.

To pursue any of the above troubleshooting methods, please contact RADIMO to confirm your readings and decide on the best approach. Certified repair specialist and tool rentals are available upon request.

## Control card

Cat. Ref & Sl. No	Test	Before installation	After installation but before laying tiles	After laying tiles
	Resistance of cables (ohms)			
	Insulation resistance			

**Note: Ensure this control card is filled & signed by a licensed electrician and safely stored along with your floor plan.**

## Warranty

**Please register your warranty online on [www.radimo.com](http://www.radimo.com)**

RADIMO provides a warranty on its RADIMAT and RADICABLE systems for a period of 10 years from date of shipment, for the material and workmanship under normal operating conditions.

In case of defective material, RADIMO's obligation will be limited to supplying a new under tile heating cable, free of charge to the customer.

The warranty does not cover installations made by unauthorized trades or faults caused by incorrect design by others / misuse / damage caused by others / damage in transit / incorrect installation and any other subsequent damage that may occur. Repair / replacement will be fully chargeable if the damage is because of any of the above reasons.

Radimo is under no circumstances liable for consequential damages or losses including without limitation the loss or profit arising from any cause whatsoever. The guarantee is a material warranty only and does not cover field labor.

The warranty is void if there is any payment default and details are not entered on the online warranty registration at [www.radimo.com/warranty-registration](http://www.radimo.com/warranty-registration).

**RADIMO**  
1-855-5-RADIMO  
[www.radimo.com](http://www.radimo.com)

Dec. 2011