

Thank you for purchasing this quality product. Be sure to check all packing material carefully for small parts which may have come loose inside the carton during shipment. Separate, identify, and count all parts and metal hardware. Compare with parts list and hardware illustrations to be sure all parts are present. If any part(s) are missing or damaged, phone fax or mail to our Customer Service Department. For efficient and speedy service, please indicate the model number and code letter of part(s) needed.

ATTENTION: SOME LETTERED PARTS LISTED ON THE INSTRUCTION SHEET MAY NOT BE IN PARTS BAG AS THEY MAY ALREADY BE ASSEMBLED. CAREFULLY CHECK PARTS AND PACKING MATERIALS PRIOR TO ORDERING REPLACEMENTS.

Tools Required for assembly: Allen wrench(F) Phillips Screwdriver (not included)

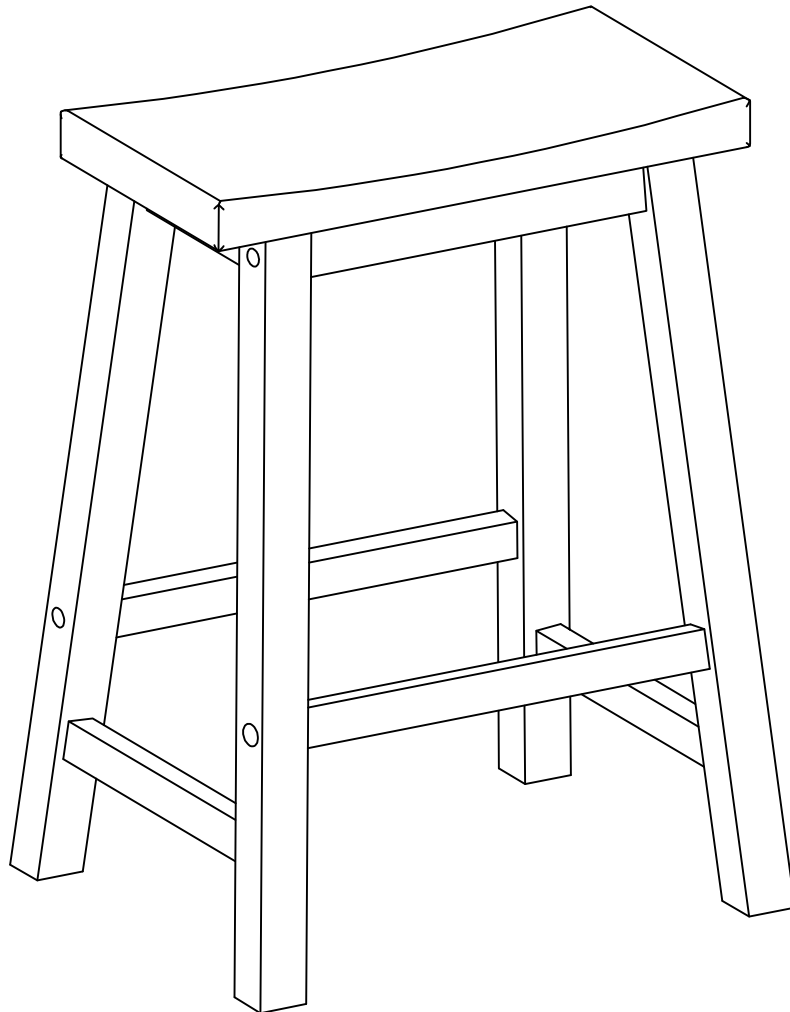

PARTS

(A) SIDE FRAME(L&R) (2)

(C) SEAT

(B) STRETCHERS (2)

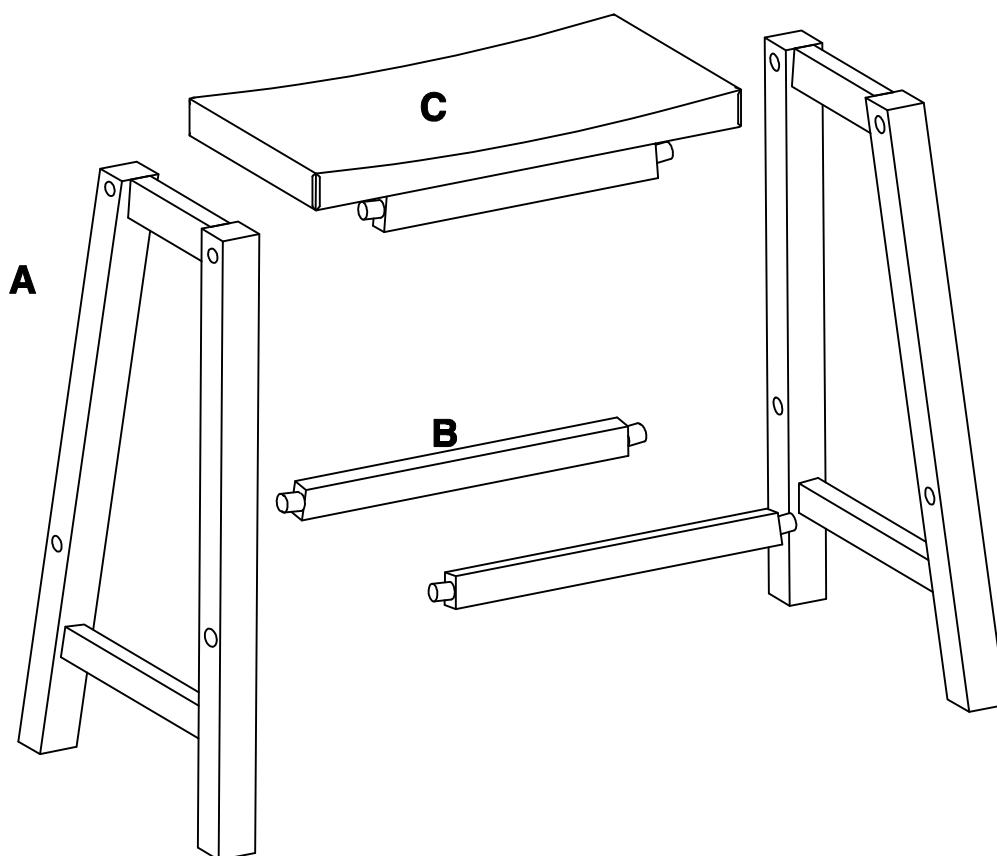

HARDWARE

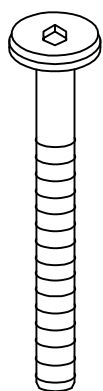

D
(8PCS)

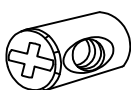

E
(8PCS)

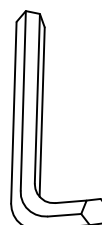

F
(1PCS)



G
(8PCS)

STEP 1

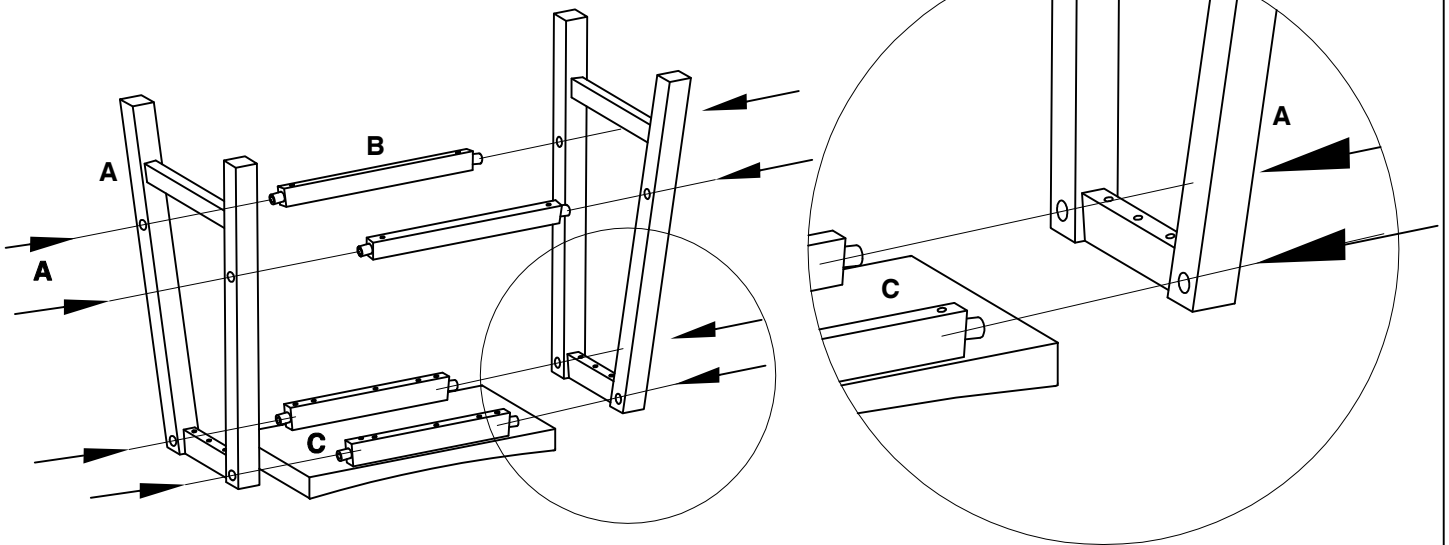

STEP 2

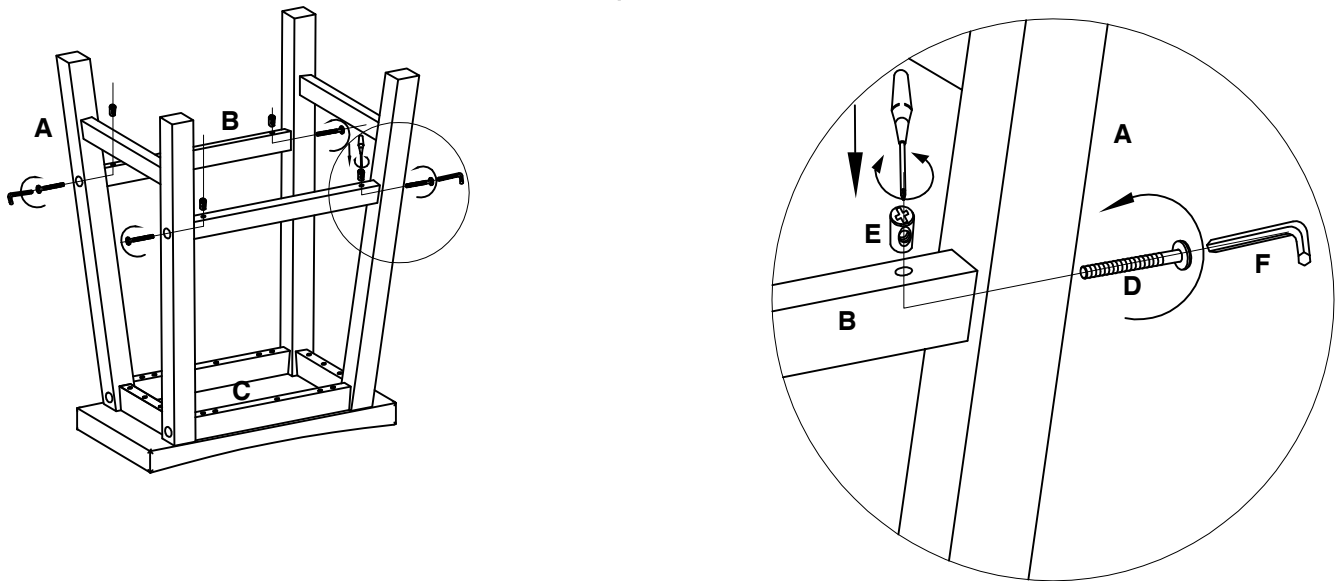

STEP 3

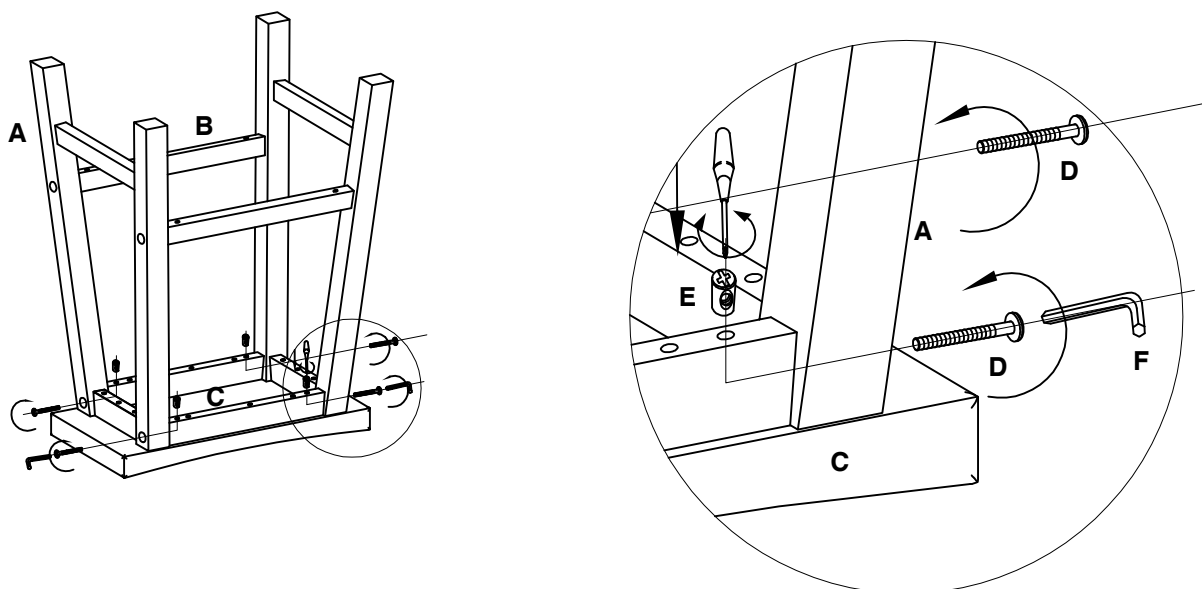

STEP 4

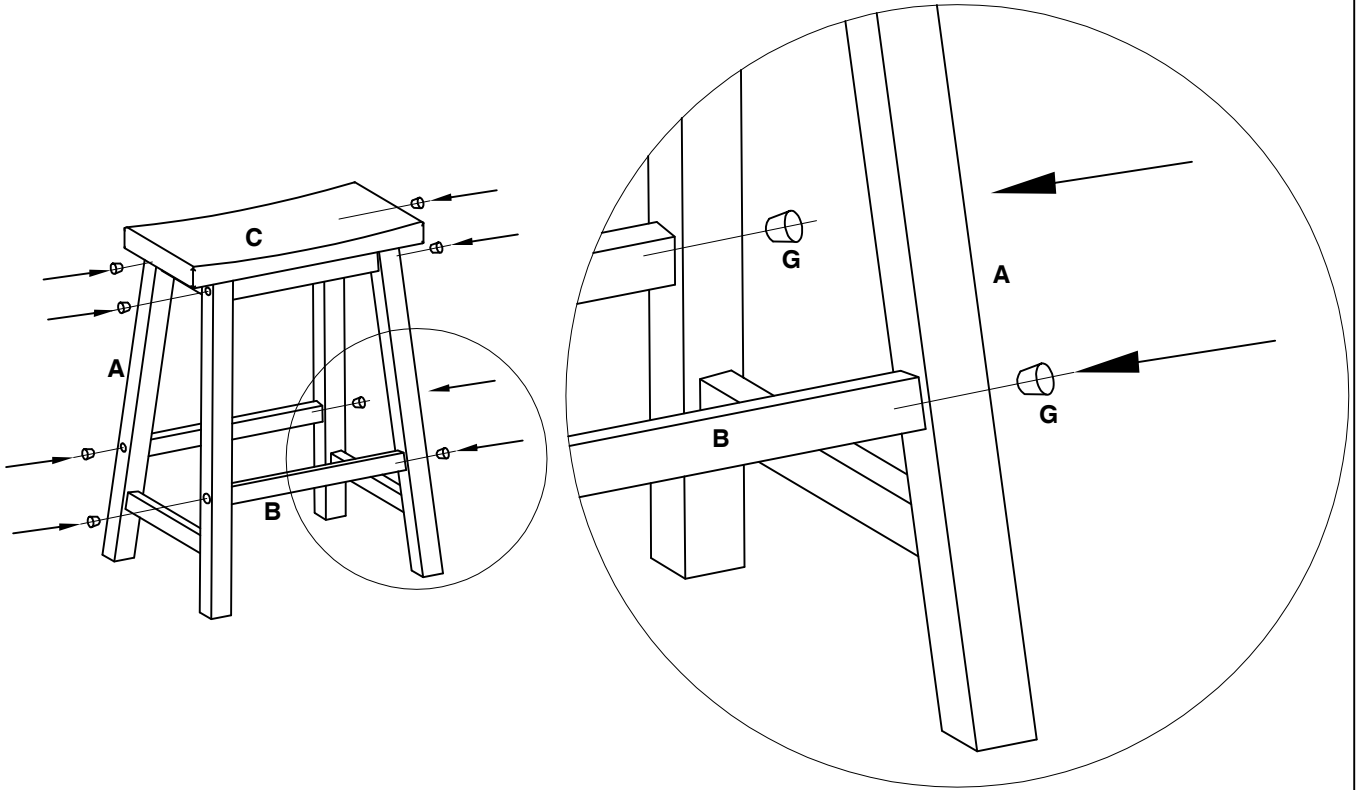

IF YOU HAVE A PROBLEM, WE WANT TO HAVE THE OPPORTUNITY TO MAKE IT RIGHT!

Should there be any missing or defective part(s)

MODEL NO: 502-430

Fax this form to (310) 841-0842

© 2006 POWELL

or call Customer Service at (310) 204-2224

Have your model number and part code letter handy.

Part Letter

Quantity

Name

Address

Daytime Phone ()

Reason for replacement

Place for purchase