

UA-PRO310



Black

Maximum Load 150 lbs (68 kg)

X-Large Articulating Mount

A modern design for an extremely flexible, articulating universal wall mount for large flat panel displays. The UA-PRO310's heavy duty Double-arm Quatro-pivot is designed for maximum extension, folding flush to the wall and viewing from multiple positions.

- The wall plate attaches to two studs up to 20" apart and concrete or aggregate walls.
- Fits Screens from 30" to 63"
VESA compliant support all patterns 200x200 to 800x400
Extends up to 25"
Complete cable management
Attractive end caps conceal tensioning bolts
All screen and mounting hardware included

www.promounts.com

UA-PRO310

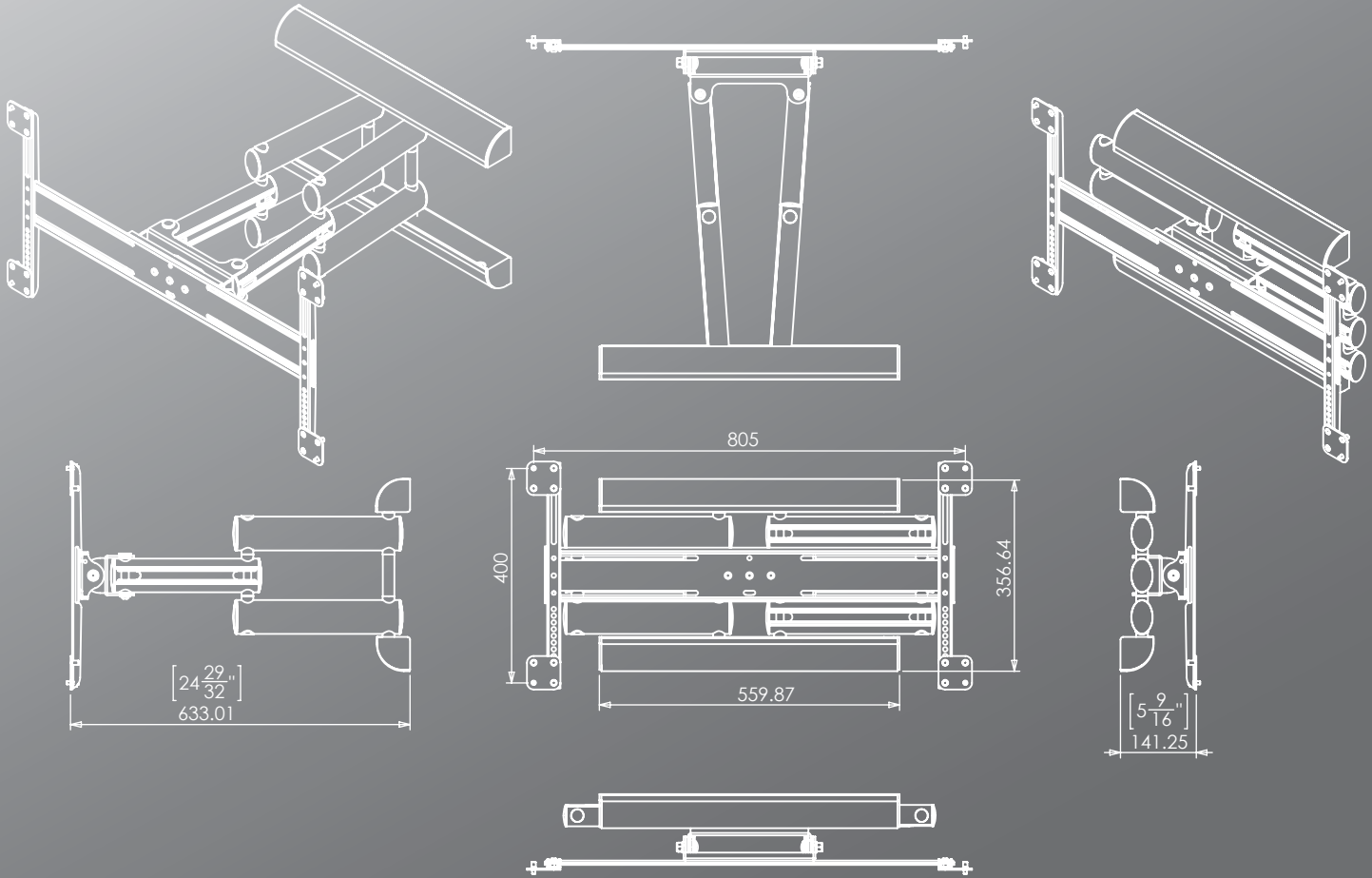

Specifications

Weight

Estimated: 40 lbs (18 kg)

Mounting

We recommend that this product be installed by a professional A/V installer

Dimensions

TBA

Architects and Consultants: please contact ProMounts customer service for necessary drawings and files. For complete high resolution images, technical specifications and drawings please visit www.promounts.com and click on Download Center.

ProMounts: 5741 Buckingham Parkway, Unit C, Culver City, CA 90230 **Phone:** 866 668 6872, or 310 645 6400 **Email:** info@promounts.com Fax: 310 645 0189 **ProMounts** is a division of Scadlock LLC

www.promounts.com