

**GatekeeperLtd.**  
[www.gatekeeperltd.com](http://www.gatekeeperltd.com)

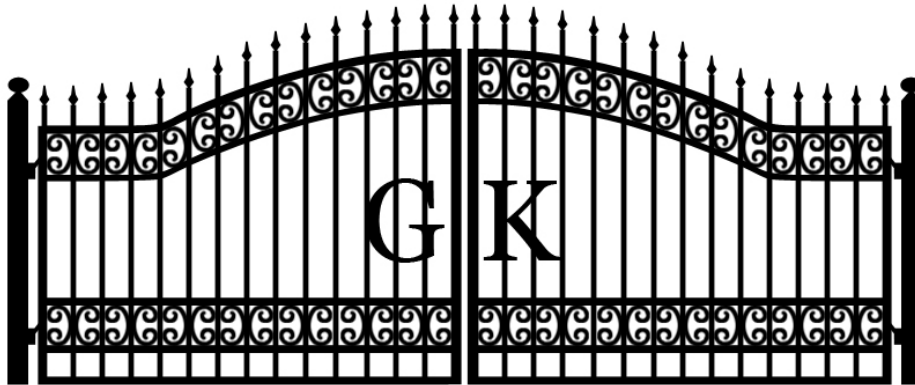

Guard Your Yard

**YG-5602/1U/E SWINGING GATE  
OPENER**

**OWNER'S MANUAL**



©2011

Gatekeeper Ltd.

P.O. Box 752

Lacey's Spring, AL 35754

<http://www.gatekeeperltd.com>

## Table of Contents

1. Safety Precautions.....	4
2. Features .....	5
3. Specifications .....	5
4. Necessary Tools and Equipment.....	6
5. Site Preparation .....	6
5a. Standard Power .....	6
5b. Solar Power.....	6
5c. Equipment Check.....	7
5d. Parts for Gate Arm Installation .....	8
5e. Actuator Specifications and Measurements .....	9
6. Gate Arm (Actuator) Installation .....	10
6a. Determine Gate Open Direction .....	11
6b. Pull to Open Inward.....	12
6c. Push to Open Outward .....	13
7. Stopper and Latch Installation .....	14
8. Electrical Installation .....	16
8.1 - Connecting the AC Power .....	16
8.2 - Wiring the Battery (see Fig.7b) .....	17
8.3 - Wiring the Actuators .....	17
8.4 - First Time Activation Test.....	18
9. Using the RF Remote Control.....	18
10. External Interfaces .....	20
10.1 - Keypad/ Button Switch .....	20
10.2 - Loop detector.....	20
10.3 - Safe guard (Infrared device or Photocell).....	21
11. Advanced Control Wiring.....	22
11.1 -Visual Guide for Wiring .....	24
13. Auto-close function.....	26
14. Additional Features .....	26
15. Operation Notes on the Gate Opener System .....	27
16. Maintenance & Troubleshooting .....	28
17. Gatekeeper Ltd. Limited Warranty .....	30

THIS PAGE INTENTIONALLY LEFT BLANK

# 1. Safety Precautions



Installing the YG-5602/1 Gate Opener requires installation of standard 110V or 230V electrical wiring. This work should only be performed by a trained technician. Mis-wiring could cause personal injury or DEATH. To prevent the risk of electrocution, be sure to turn off all power to the YG-5602/1 until installation is complete.

- Please keep hands, fingers and loose clothing away from moving parts as they may be dragged into moving parts.
- The gate may move at any time. Ensure all persons are clear of the gate when it is moving to avoid the risk of injury. Do not touch the gate while it is in operation. Do not attempt to go through the gate while it is still in motion. This opener is intended for vehicular use only.
- Do not allow children or pets near your gate. Keep the remote controls away from children. Place controls where they cannot be accessed by reaching through the gate.
- To avoid electric shock, unplug unit before opening case.
- Make sure the battery inside the opener is charged fully before using.
- Before installation, the clutch should be unlocked.
- The auto-reverse function must be checked during installation to ensure that the gate can auto-reverse in the event of obstruction, and it should be inspected regularly.
- The automatic gate opener must be grounded.
- Install the gate opener on the inside of the property; DO NOT install it on the outside of the property where the public has access to it!
- Additional safety equipment such as photoelectric sensors, safety edges, roller guards and warning signs must be installed to prevent injury.
- In the event of power failure, an emergency release key allows you to operate the gate manually.
- Please erase and reset the code after installing the opener.
- The gate opener should be installed by a qualified technician; otherwise, serious personal injury or property damage may occur.

**For service, call an experienced technician. Do not in any way modify the components of the automated system; otherwise serious personal injury or property damage may occur. We do not accept responsibility for damage or injury resulting from the installation of this opener.**

## 2. Features

**Class I:** A vehicular gate opener (or system) intended solely for use in a single family home, or an associated garage or parking area.

### ADDITIONAL FEATURES

- Supports single or dual gate operation.
- Adjustable auto reverse function for safety purposes.
- Built-in battery backup in the event of power loss.
- Auto-close feature with 3 wait times: 12/25/50 selectable by dip switch.
- Battery low-voltage detection to avoid battery damage.
- Automatic slow down feature to decrease noisy closing.
- Keypad / single button interface.
- Infrared safety beam interface.
- Supports up to 15 RF remotes, 2 included.
- User programmable and user erasable remote codes.
- RF hopping code technology prevents thieves from guessing your remote code.
- Manual key release design for emergency purposes.
- Supports Keypad interface and Magnetic Loop Detectors simultaneously.

## 3. Specifications

Power Supply	U Model 110V AC (60Hz) E Model 230V AC (50Hz)
Backup Battery:	12VDC / 4AH
Maximum Number of Remote Controls	15 (2 Included)
Maximum Gate Weight	300 KG / 661 lbs
Maximum Gate Width	3.6 meters / 12 feet per leaf
Duty Cycle	50%
Working Temperature Range:	-20°C - ~55°C, -4°F – ~131°F
Power Consumption:	150W (Max) 5W (Standby)
Power Supply of the Motor	12VDC/8A, 96W (MAX)
Power Supply of the Lamp:	12VDC, 21W (MAX)
Power Supply of the Electric Lock:	12VDC, 60W (Max)
Power Supply of the Receiver:	12VDC, 2W (Max)
Power Supply of the Accessories:	12VDC, 3W (Max)
Over-current-protection:	3.5A~7.5A
Pause Time:	Programmable, 0 sec ~ 50 sec
2 <sup>nd</sup> Leaf Closing Delay:	Programmable, 0 sec ~ 8sec

Dimensions and Weight:	300 x 245 x 90 mm, 4.6kgs 11.8"x9.65"x3.5", 10.1 lbs
------------------------	---

## 4. Necessary Tools and Equipment

The following tools may be necessary to install the YG-5602/1 Gate opener.

- Standard and Philips screw drivers
- Electric drill
- Wire cutters
- Wire stripper
- Socket set
- Welder

## 5. Site Preparation

Before you begin the opener installation, check the following.

1. The gate should be mounted and moving freely with little resistance in movement.
2. The gate and post must be suitable for being automated. Check that the structure is sufficiently strong and rigid, and that its dimensions and weights conform to those listed in the specifications table of this document. (page 5)
3. Make sure that the gate is plumb and level.
4. The fence posts must be mounted in concrete.

### 5a. Standard Power

The YG-5602 is normally powered by U/E standard power (U model 110V/60Hz AC ; E model 240V/50Hz AC power) If you have not already done so, wire a waterproof outlet near the gate following proper safety standards for your area. **If you are not experienced with this type of wiring or if your area requires it, hire a professional electrician to perform this as well as wire in the YG-5602 in the electrical section.**

The YG-5602 requires at least a 15A service. Make sure your electrician takes into account the voltage drop involved in running many feet of wire to your installation location. If an insufficient gauge of wire is used, there will be insufficient power at the site to operate the opener.

### 5b. Solar Power

If you plan to use solar panels to power your gate, verify that you have sufficient solar power to charge the battery and provide power for the number of openings and closings you plan to need. Different areas of the planet receive varying amounts of sunlight, and that amount varies on the time of the year. Make sure you account for all this in any solar installation.

**If insufficient power is available, the opener battery can be permanently damaged and this is not covered under the warranty.**

## 5c. Equipment Check

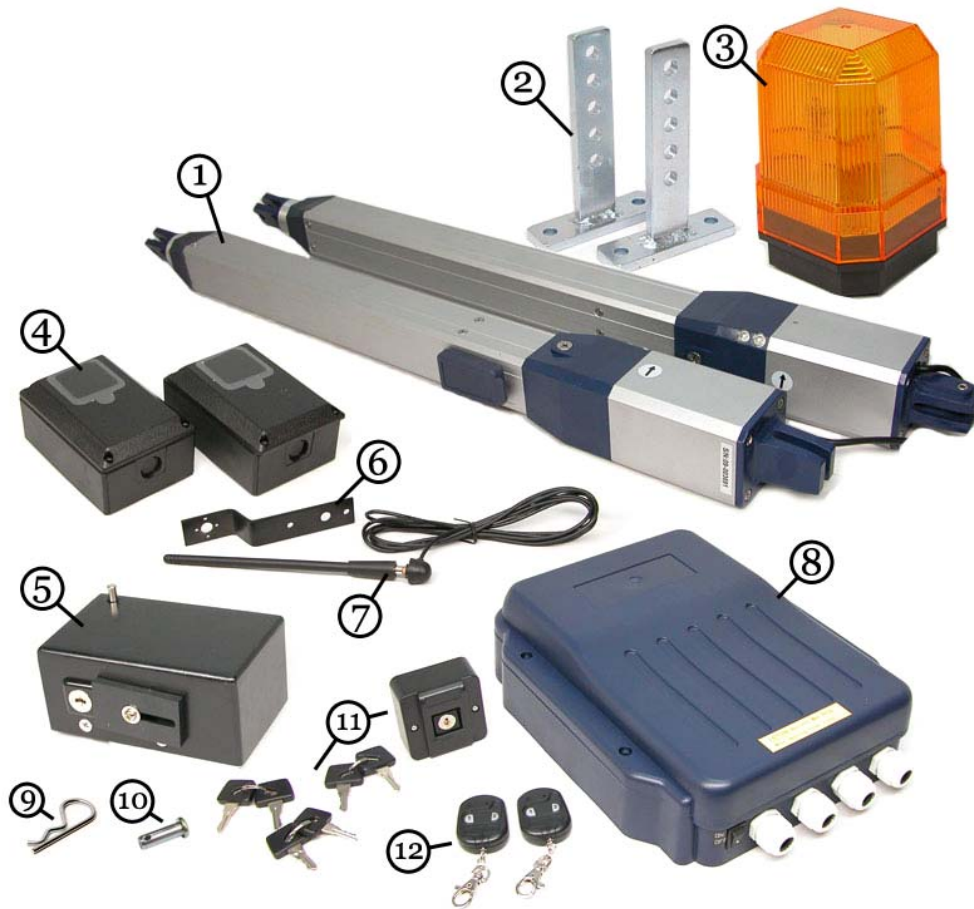

1. Swinging Gate Actuator
2. "T" Mounting Bracket
3. Flashing light
4. Through beam type infra-red photo sensor
5. Electric Latch with Keylock
6. Mounting bracket
7. Antenna
8. Control box
9. Cotter Pin
10. Clevis Pin
11. Keys and manual key-lock
12. Remote key

\* Not shown in picture

1. Stop Block
2. "L" Mounting bracket
3. Bar Mounting bracket
4. Assorted bolts and nuts



## 5d. Parts for Gate Arm Installation

You need the following parts to connect an actuator to your gate.

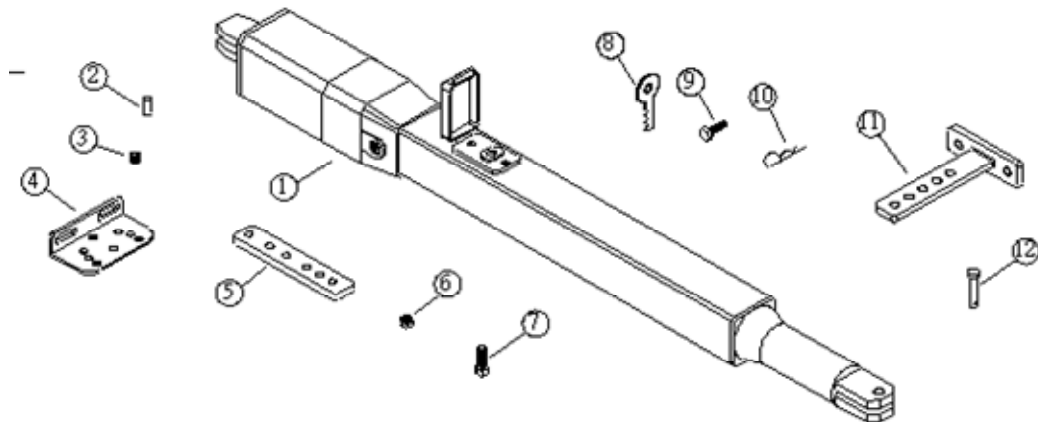

No	Description	Quantity	
		Single	Dual
1	Actuator	1	2
2	Nest Pin	1	2
3	Fastener Screw	1	2
4	"L" Mounting Bracket	2	4
5	Bar Mounting Bracket	1	2
6	Nut for Bolt	2	4
7	Bolt	2	4
8	Release Key	1	2
9	Bolt	6	12
10	Cotter Pin	1	2
11	"T" Mounting Bracket	1	2
12	Front Clevis Pin	1	2

## 5e. Actuator Specifications and Measurements

1. Actuator Maximum Direct Force: 1400N , 315 lbs
2. Actuator Maximum Power Consumption: 12V at 6A = 72W
3. Duty Cycle: 50%

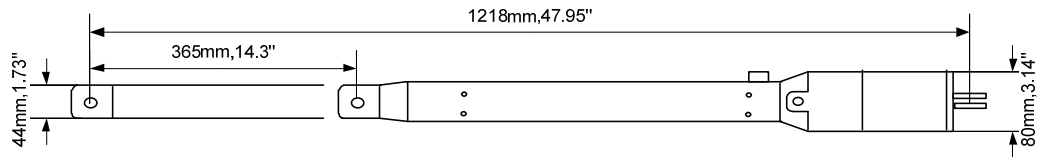

Actuator

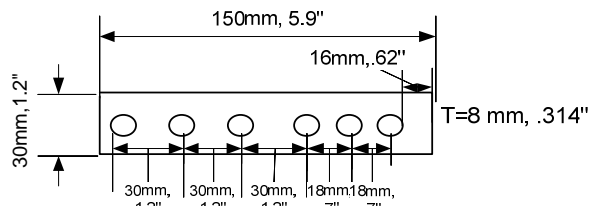

Bar Mounting Bracket

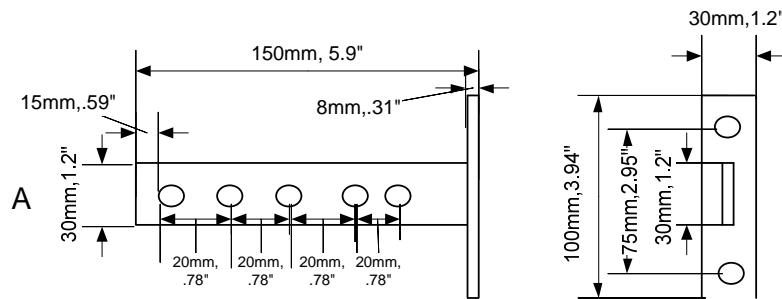

"T" Mounting Bracket

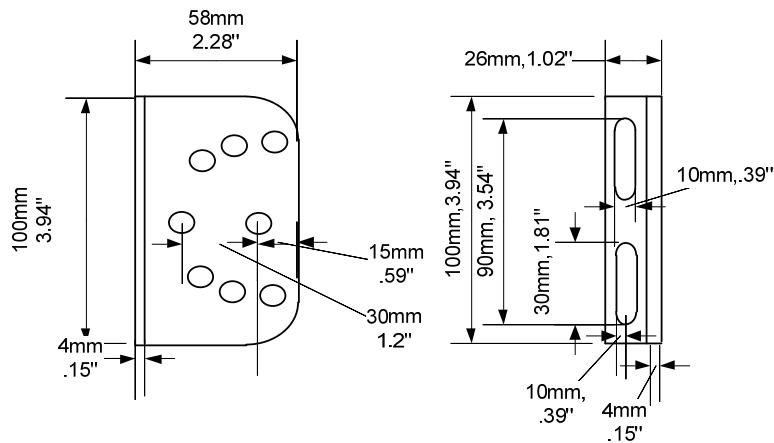

"L" Mounting Bracket

Figure 1.

## 6. Gate Arm (Actuator) Installation

Before proceeding to the installation, make sure you read through the following.

### Gate Size and Weight Limitations

The YG-5602/1 Swing Gate Opener will handle gates weighing up to 300Kg (661lb) and up to 3.6m (12 ft) per leaf if the proper installation procedures have been followed. The YG-5602 gate operator operates by forcing a worm gear to extend inside each actuator pushing or pulling the gate open.

### Gate preparation

Be sure the gate is properly installed and swings smoothly before installing the YG-5602 swinging gate opener. The gate must be plumb, level, and move freely. More detailed instructions on **page 6 (Sec.5. Site Preparation)**

### Conduit

In order to protect the wires, use PVC conduit for wires. It may be necessary to preset the conduit into the concrete when it is poured. Wires within the conduit shall be located or protected so that no damage can result from contact with any rough or sharp part. More detailed instructions on **page 6 (Sec.5a Standard Power & 5b Solar Power)**



PVC Conduits are usually pipes, but are also available as flexible tubes

**Once the gate is mounted adequately, and electrical power is available, you are ready to proceed with the YG-5602 installation.**

## 6a. Determine Gate Open Direction

Begin with both openers unlocked. Next identify if this will be a “push to open” or a “pull to open” installation. In either configuration, the gate is mounted on one face of the mounting post, and the opener is mounted on the face 90 degrees from it. Below are schematics of both “push to open” and “pull to open” configurations.

### A. PULL TO OPEN INWARD

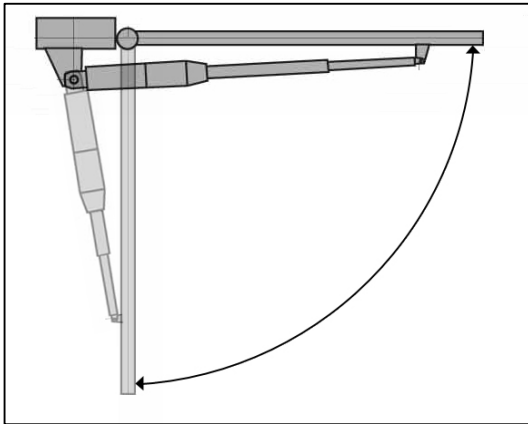

Figure 2.

Use this setup to make your gate open inward, toward your property.

### B. PUSH TO OPEN OUTWARD

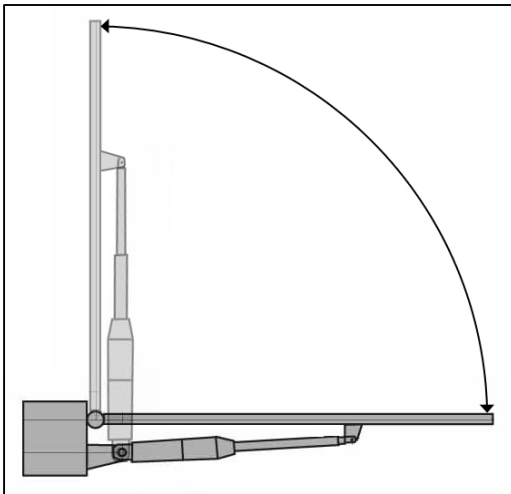

Figure 3.

Use this setup to make your gate open outward, away from your property



A properly installed Open Inward actuator

## 6b. Pull to Open Inward

Mount the actuators on the included brackets according to the figure below. The gate is mounted on one face of the mounting post, and the opener is mounted on the face 90 degrees from it. The actuator mechanism should always be inside the property so that it cannot be tampered with from the outside. Initially mount the actuators on the gate so that the gate is open.

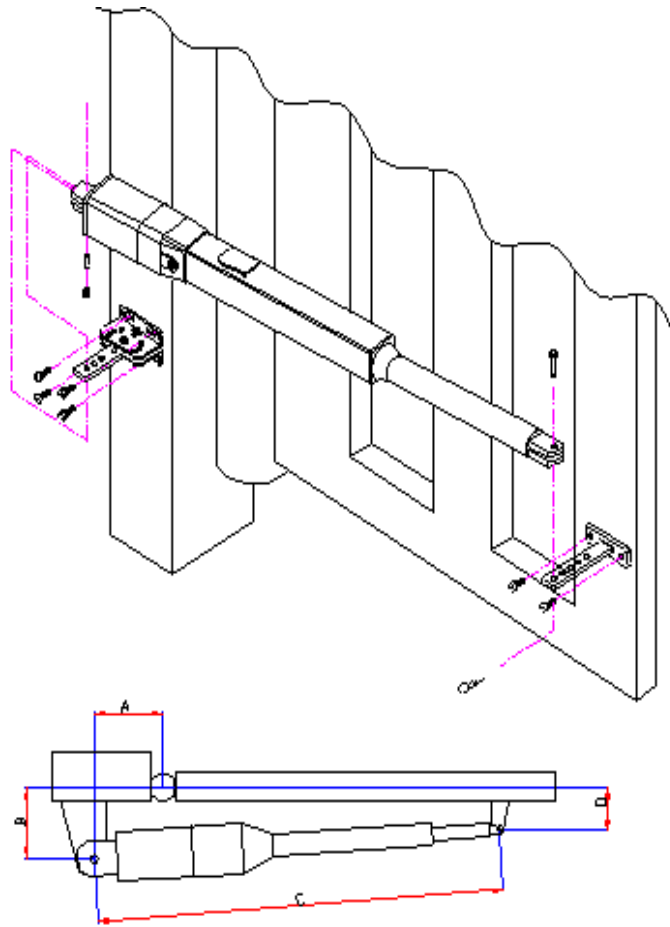

Figure 4.

Opening Angle	A cm	A inch	B cm	B inch	C cm	C inch	D cm	D inch
90	17.5	6.88	14.5	5.7	117.8	46.38	6.5	2.56
110	18	7.08	9.5	3.74	118.3	46.57	6.5	2.56

The installation should meet the specifications shown in the figure. Failure to do so may cause opening and closing problems.

## 6c. Push to Open Outward

Mount the actuators on the included brackets according to the figure below. The gate is mounted on one face of the mounting post, and the opener is mounted on the face 90 degrees from it. The actuator mechanism should always be inside the property so that it cannot be tampered with from the outside. Initially mount the actuators on the gate so that the gate is open.

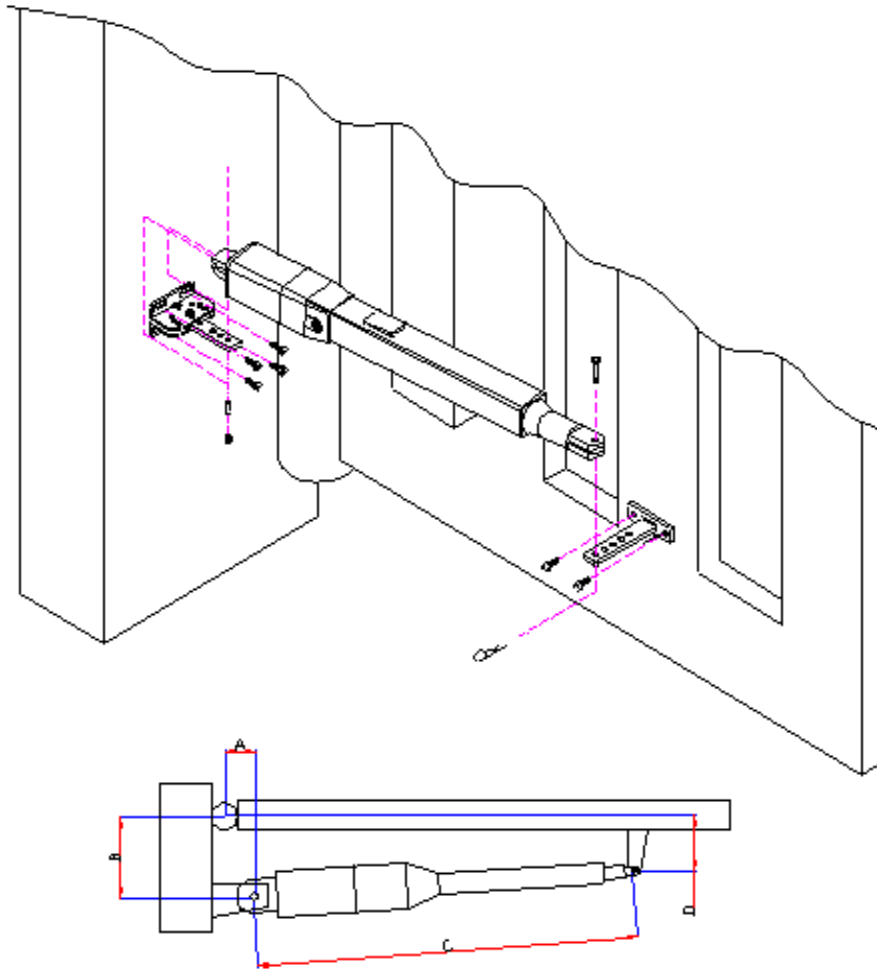

Figure 5.

Opening Angle	A cm	A inch	B cm	B inch	C cm	C inch	D cm	D inch
90	8.5	3.34	13	5.12	97	38.12	6.5	2.56
110	12.5	4.92	11	4.33	85.9	33.82	6.5	2.56

The installation should meet the specifications shown in the figure. Failure to do so may cause opening and closing problems.

## 7. Stopper and Latch Installation

### WITHOUT Electrical Latch

1. Install Stopper 1: stops gate in closed position.
2. Install Stoppers 2: stops gate in maximum opened position.

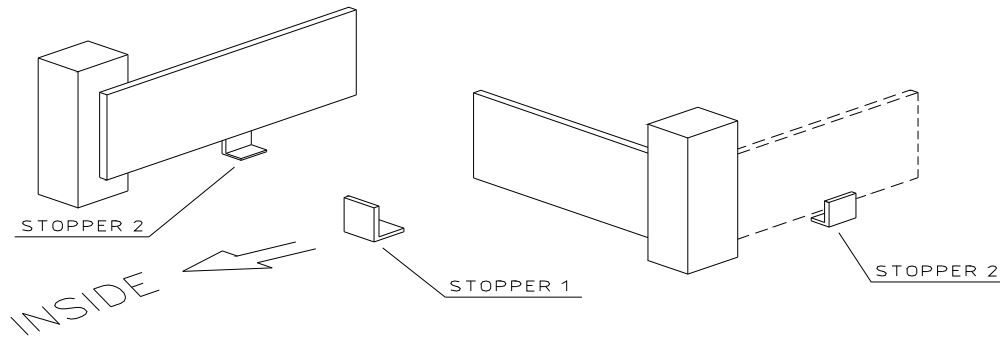

Figure 6a.

### With Electrical Latch (OPTIONAL)

3. Install the Electrical Latch and the Slave Gate Stop on the gate as shown in the diagram.
4. Install the L Bar on the opposite gate
5. Install Stopper 1: stops gate in closed position.
6. Install Stoppers 2: stops gate in maximum opened position.

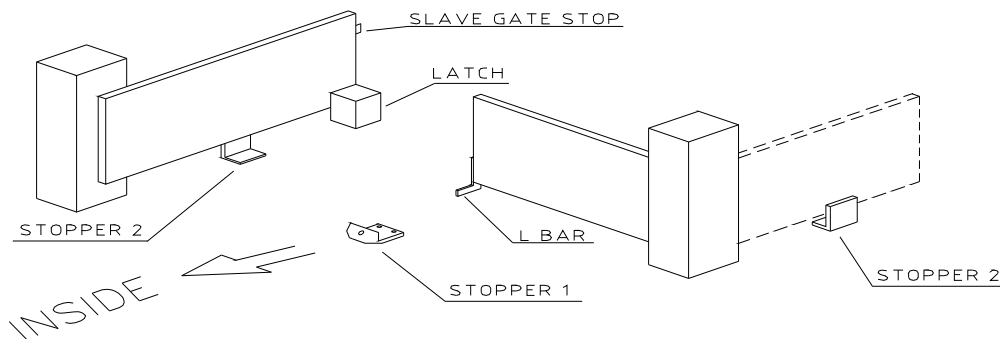
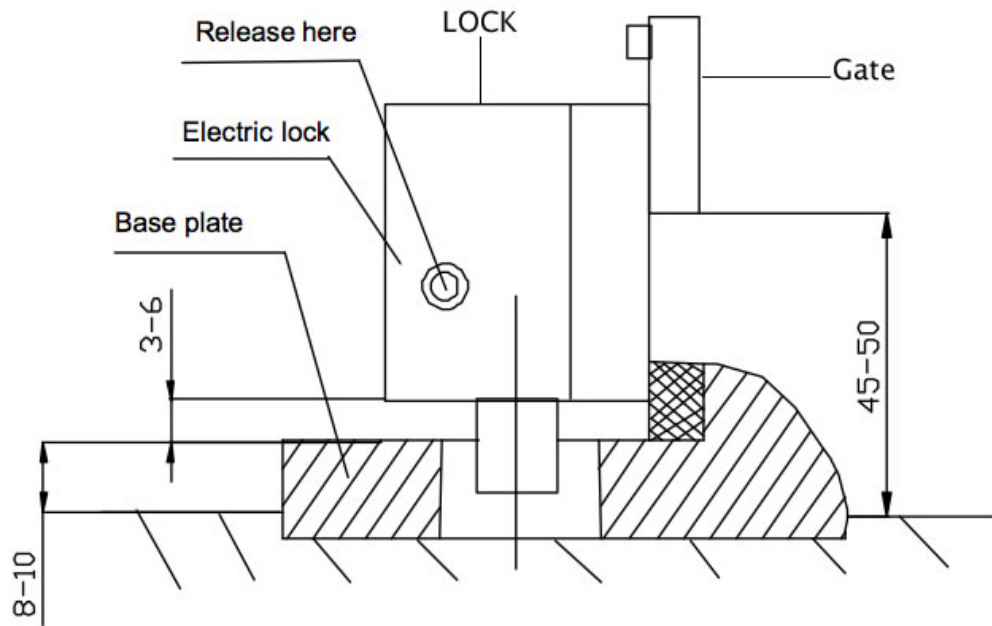

Figure 6b.

See "YG-Series Lock Installation Cross Section" on the next page to understand how the Electrical Latch functions.

## YG-Series Lock Installation Cross Section View



\*Measurements in CM

To install the base plate of the lock, fix the plate to the ground with 3 screws and make sure that the lockpin can fit tightly in the hole in the plate

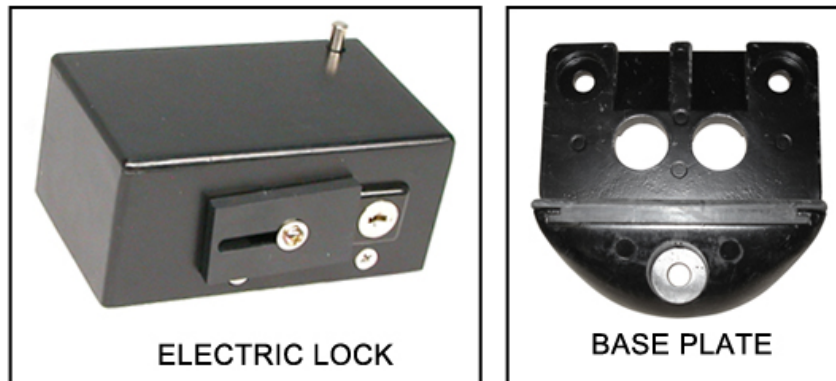

Figure 6c.

### Mechanical Maintenance

- Regularly verify that the gate swings freely.
- Add grease to the gate as directed by the manufacturer of the gate.
- Check that wiring and other electrical parts are weather-proof.
- Keep opener clean at all times.



## 8. Electrical Installation

### CONTROL BOX DIAGRAM

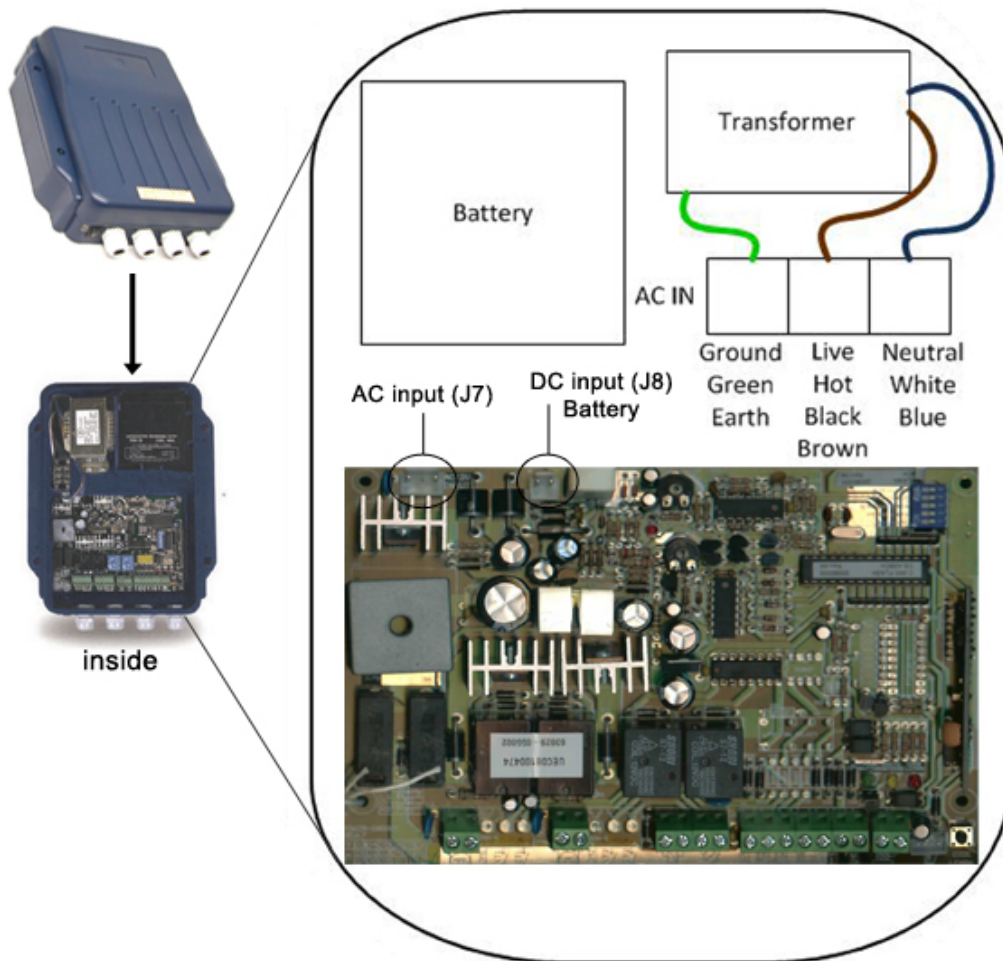

### 8.1 - Connecting the AC Power

The control box should be equipped with a single-phase breaker (15A). Make sure that the power is OFF before making any electrical connections. Remove the cover of the control box, perform the wiring and replace the cover again.

Wire your AC line into the AC IN terminal at the top of the control box near the transformer.

- Wire the ground (usually green) to the terminal on the left.
- Wire the hot (usually black) wire to the middle terminal.
- Wire the neutral (usually white) wire to the terminal on the right.

Verify that all electrical connections are waterproof by installing electrical outlets into exterior grade boxes with waterproof covers. Make sure that whenever an electrical connector enters or exits a box it is sealed. If using solar, verify that all connections are waterproof. **Please Note the system cannot execute the learning mode (remote control) by battery power only. Once your breaker is activated, the LED should light.**

## 8.2 - Wiring the Battery (see Fig.7b)

Inside the control box, connect the red battery lead to 'BAT+' terminal of control board, and black battery lead to 'BAT-'. Use terminal J8 for the battery.

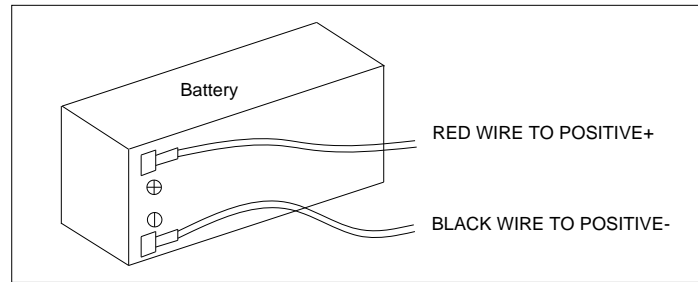

Figure 7b.

### Definition of flashing light codes:

Quick flashing light	Systems operation is at slow down speed or the system is in learning mode / kickback / extra-push phase.
Normal flashing light	System is operating at the full speed.
Slow flashing light	Gate is waiting for auto close execution.
Lamp fixed light 7 sec without gate movement	Gate is in a waiting mode since the photocell has been covered by obstacle during the gate closing or opening.

## 8.3 - Wiring the Actuators

Connect the wires from the master or number one gate actuator to the MM1 terminals 1& 2 on the control board. Connect the wires from the slave or number 2 gate actuator into the SM2 terminals 3 & 4 on the control board. If using a single gate only, then connect the single actuator to MM1 only.

**Make sure that the actuators are mounted so that when activated they will close, i.e. mount the actuators so that the gate is open (actuators are retracted).**

## 8.4 - First Time Activation Test

### Two Gate Operation

Press the button for channel 2 on the remote control (black button) and the programming systems will enter into "system self – learning mode". The lamp will start quick flashing and the motors (one by one) will start moving through the following steps:

Slave Gate will Close (actuator extending) → Master Gate will Close (actuator extending) → Master Gate will Open (actuator retracting) → Slave Gate will Open (actuator retracting) → Slave Gate will Close (actuator extending) → Master Gate Will Close (actuator extending).

### Single Gate Operation

For the single gate, when the system receives a signal from channel 2, the lamp will start quick flashing but the system will execute learning motion after 75 sec. The learning mode will execute as the following step:

Master Gate Close (actuator extending) → Master Gate will Open (actuator retracting) → Master Gate Will Close (actuator extending)

### Verify open direction

If the gate does not move in the desired direction, then you will need to reverse the motor operating direction. No matter which method of installation is used, pull to open or push to open, the first operation should be defined as gate closing phase during the procedure for learning. If the system executes the opposite motion during the learning mode, please swap the wires of the motor to the correct polarity.

### Determine if Adjustment is Required

During the "system learning mode", there are two situations that need to be adjusted for using the VR1 (over current sensitivity / obstruction sensor)

- If one leaf stops before arriving at the end of travel.
- If one leaf stops at end of travel but the other leaf is not moving and the lamp is still quick flashing.

**After adjusting the VR1, repeat the self-learning system from the beginning.**

#### **Important**

During the "System Self Learning Process", if any command interrupts the leaf's travel (Transmitter or Push-button or other abnormal stop), the "System Self Learning Process" will not be successful and the "System Self Learning Process" must be repeated again from the beginning.

**In case of the absence of a power supply, the stored learning memory will be lost and the systems should execute the "System Self Learning Process" again.**

## 9. Using the RF Remote Control



**BUTTON 1 - Main button**

- Opens both gates
- Used for registering control

**BUTTON 2 - Pedestrian button**

- Opens single gate (if enabled)

Fig.8

**WARNING:** Notify the users that the gate is never to be operated unless it is in full view.

### **How to add an additional remote control**

Please press button **SW2**, the L4 (LED for code learning) will be turned on and the receiver module will be changed to the "RF Remote Learning Mode" for 30 seconds. During the "RF Remote Learning Mode" period, press the main button one (black one on the left) of the transmitter, it will then be memorized (up to 15 different transmitters can be memorized). After the LED light is turned off, the receiver module will go back to the "normal mode" and the system can be operated normally.

Up to 15 remote controls may be used. Additional RF Remote controls can be obtained through your dealer. To find a dealer go to [www.gatekeeperltd.com/dealers](http://www.gatekeeperltd.com/dealers)

### **How to erase remote controls**

To erase existing remote controls, the memory can be cleared completely if the SW2 (code learning) is pressed continuously for 10 seconds.

## 10. External Interfaces

### 10.1 - Keypad/ Button Switch

The YG-5602 is equipped with an interface for an external switch or keypad. The interface type is a NO (Normally Open) momentary switch to ground. To activate the opener, the keypad or other device must short the 'GND'(12) and 'Push Button 2'(10) terminals momentarily on Box J4. This type of switch is very common. To install the device, attach one lead of your keypad to the 'Push Button (10)' terminal and the other to the 'GND' (12) terminal. If your keypad requires 12Volts DC, then you can connect the 12V+ to (9) and the -V DC to (12). The keypad will function in single channel mode just like the RF remote.

If the gate is closed, then activating the keypad will open the gate. If the gate is open, then activating the keypad will close the gate. If the gate is moving, then activating the keypad will stop the gate. Consult your device manufacturer's documentation for details. The keypad device can be obtained through your dealer. To find a dealer, go to [www.gatekeeperltd.com/dealers](http://www.gatekeeperltd.com/dealers)

### 10.2 - Loop detector

A magnetic loop detector detects vehicles that are within proximity to the gate. A magnetic loop detector can be used to open the gate when a car pulls up either from the inside or the outside depending on which side of the gate you install it. A magnetic loop is usually buried under the ground, and the wires run to the gate opener control board.

Magnetic loops usually require DC power, using the + and - DC terminals. Connect the 12V+ to (9) and the -V DC to (12). They provide a normally open momentary switch interface to the control board and its ground or common interface. Wire the magnetic loop's normally open trigger wire to terminal (10) and the normally open ground or common to GND (12) both on block J4.

Consult your device manufacturer's documentation for details. See Figure 4 for a diagram of external interface connections. The Loop Detector device can be obtained through your dealer. To find a dealer, go to [www.gatekeeperltd.com/dealers](http://www.gatekeeperltd.com/dealers)

### **10.3 - Safe guard (Infrared device or Photocell)**

It is recommended that the installer install the included infrared photocell for additional safety. Photocells work by inhibiting the movement of the gate if the beam is broken. Infrared safety devices may be required by law in some areas.

If the infrared beam is broken during closing, the gates will reverse and open immediately. During opening, the beeper will ring.

Infrared photocells come in active and passive varieties. Active photocells require power on both sides of the driveway, whereas passive photocells employ a reflector plate so that power is only required on one side of the driveway. Most photocells will provide DC power input wires + and -, and 2 normally closed switch wires. To install the photocell, remove the short circuit wire between Terminals (14) and (15). Attach the normally closed wire to (14) and the other common normally closed wire to (15) (COM). Attach the +12VDC power for the photocell to (13) and the -DC power to (15).

The signal wires are not polarized so they can be interchanged without issue, but the power wires must be wired correctly to prevent damage. Consult your device manufacturer's documentation for details.

In the closing phase, if an obstacle breaks the infrared beam of the photocell, then the gate will stop and reverse after approx 3 seconds. In the opening phase, the function of the photo sensor can be selected between active or passive. If the photo sensor is set for the active mode, and the infrared beam is broken, then the system will stop and wait for a new command.

The infrared device is included in your kit, additional devices can be obtained through your dealer. To find a dealer, go to [www.gatekeeperltd.com/dealers](http://www.gatekeeperltd.com/dealers)

## 11. Advanced Control Wiring

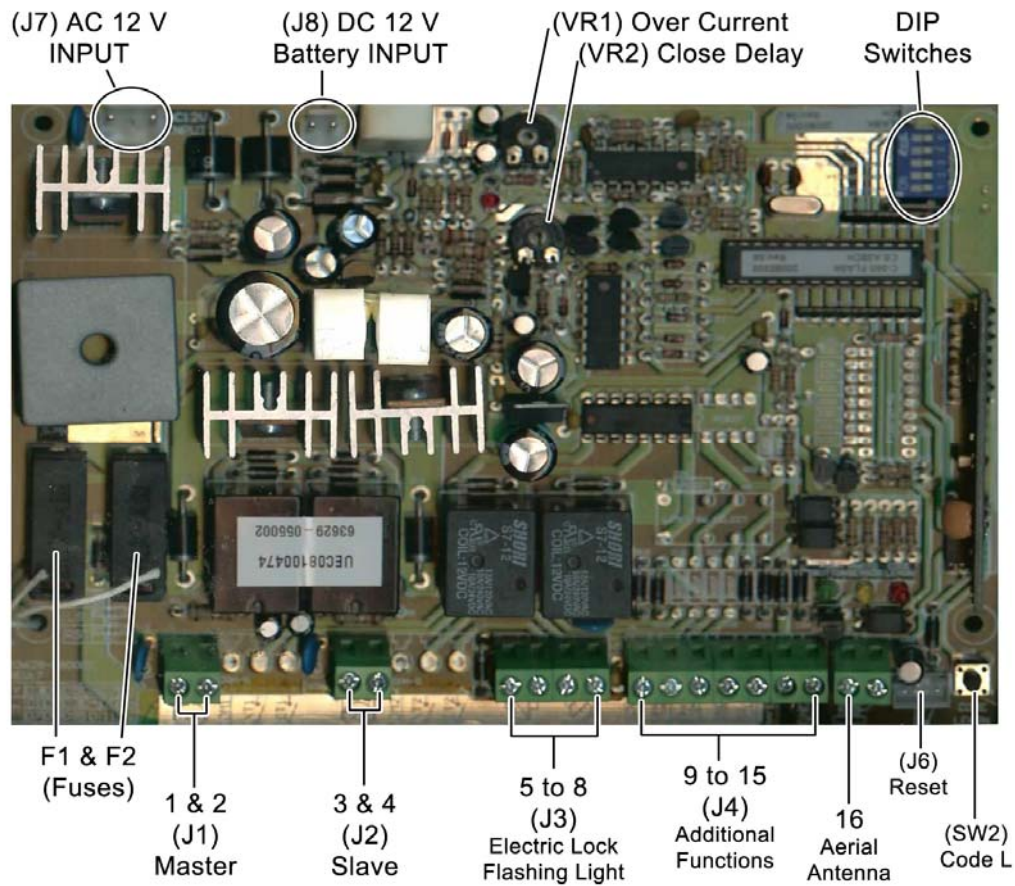

F1 - fuse (maximum 0.5A) PCB

F2 - fuse (maximum 15A) Over current

J1 - 1&2 MM1 Master gate

J2 - 3&4 SM2 Slave gate

J3 - 5&6 Electric lock, 12VDC, Max current 5A

J3 - 7&8 Flashing light. 12VDC, Max power 21W

J4 - 9 Positive Supply 12V DC

J4 - 10 use with 12 Keypad / Pushbutton for the dual gate operation

J4 - 11 use with 12 Keypad / Pushbutton for the single gate operation

J4 - 12 Logical and Power Ground for external devices

J4 - 13 Positive Supply 12V DC

J4 - 14&15 Photo sensor contacts, must be shorted together if no photocell

J5 - 16 Aerial Antenna cable (Connect to Aerial for increased range)

J6 - Reset Switch

SW2 - This button is used for code learning.

VR1 - Over current limit can be adjusted from min 3.5Amp to Max 7.5Amp

VR2 - Close delay can be adjusted from min 0 second to Max 8 second

See the table on the next page for more information regarding each terminal.

F1	F1 – fuse (maximum 0.5A) The fuse protects the electronic control board in case of short circuit from receiver or photo sensor
F2	F2 – fuse (maximum 15A) This fuse is part of the Safety design for the over current protection during the system operation.
J1	MM1 Terminal block 1 & 2 Connect the cable to the MM1 for the master gate. (In gate opening operation, the master gate should be opened first) <b>Important: connect only this interface if only using the single gate.</b>
J2	SM2 Terminal block 3 & 4 Connect the cable to the MM2 for the slave gate. (In gate closing operation, slave gate moves ahead of master gate with a few second of close delay)
J3	Terminal block 5 & 6 Connect to the electric lock, 12VDC, Max current 3A
J3	Terminal block 7 & 8 Connect to the flashing light. 12VDC, Max power 15W
J4	Terminal block 13+ve & 12 -ve Connect to the external receiver board for the 12 V DC ( Positive ) and Gnd ( Negative )
J4	Terminal block 10 Connect to the push button or external receiver board for the dual gate operation
J4	Terminal block 11 Connect to the push button or external receiver board for the single gate operation
J4	Terminal block 12 to 15 <ul style="list-style-type: none"> <li>• If using the photo sensor: connect the two (one is transmitter and other is receiver) photo sensors' +VDC to 13 and GND to 12.</li> <li>• Connect the N.C to 14 and COM to 15.</li> <li>• <b>If NOT using the photo sensor, make a jumper between 14 and 15.</b></li> </ul> <b>Otherwise, the systems can't operate.</b>
J5	Terminal block 16 Connect Aerial cable
J6	Terminal block J6 Connect to the Reset Switch
SW2	This button is used for code learning.
VR1	Over current limit can be adjusted from min 3.5Amp to Max 7.5Amp
VR2	Close delay can be adjusted from min 0 second to Max 8 second



## 11.1 -Visual Guide for Wiring

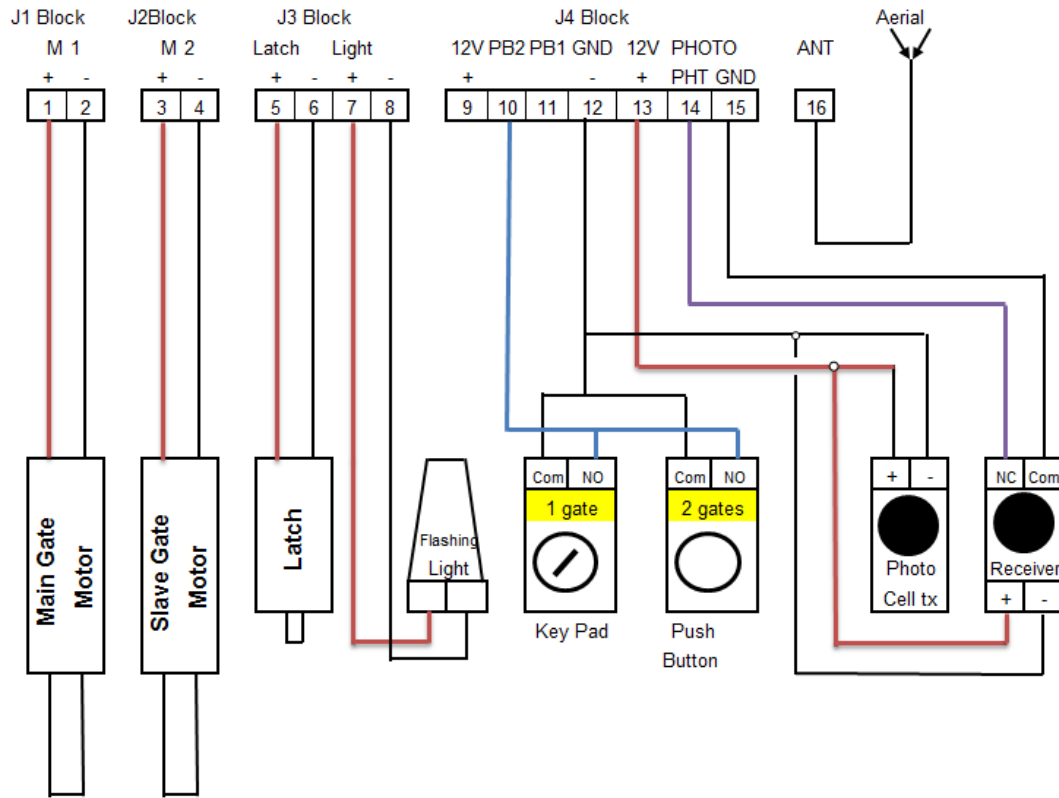

## 12. Auto-reverse function

It is very important that you tune the safety reverse function on your gate opener. Power the control box if it is not already and verify that you have completed the remote programming exercise and self learning. When properly adjusted, the gate should close and stop when it hits the stop block without overly forcing the gate, and reverse if it strikes an object before it reaches its stop. An alarm should sound if it activates the auto-reverse.

Use a screw driver to rotate the Over Current Adj. knob. Rotating clockwise will increase the resistance needed to trip the safety reverse function. Rotating counter-clockwise will decrease the resistance.

If the gate does not move when activated, or auto-reverses without striking an obstacle, then the resistance setting may be too little. If the gate does not stop when an obstruction is placed in its path, then the setting may be too high. Start with just above the minimum value, and tune it to use the minimum setting for which the gate will function.

**WARNING:** Do not attempt to tune the gate by placing your hand, arm or other body part in the path of the gate. This could result in serious injury. Also placing a heavy immovable object in the path to test with could cause damage to the gate opener motors. Instead, place a light object in the path, preferably something like a chair or trash can which will be pushed out of the way if the setting is still too high without causing damage to the gate motors. Note, this auto-reverse function should be regularly inspected and adjusted if necessary. Once this step is complete, replace the cover and install the rubber caps over the screws.



### OVER CURRENT SENSITIVITY:

The limit of Over-Current can be adjusted from Min 3.5Amp to Max 7 Amp.

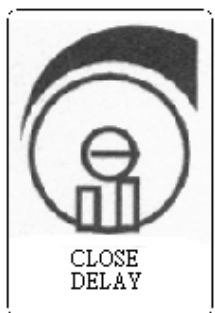

**CLOSE DELAY:** The time for the SM2 (slave leaf) start delay for gate closing can be adjusted from Min 0 second to Max 8 second.

## 13. Auto-close function

This feature can be selected to make the gate stay open for some time before it automatically closes, The auto-close time can be adjusted to 12, 25, or 50 seconds.



**AUTO CLOSE1:** The function of auto close or without auto close can be selected



**AUTO CLOSE2:** The function of auto close or without auto close can be selected

DIP4 (Auto close1)	DIP5 (Auto close2)	Function
OFF	OFF	Without auto close function
OFF	ON	Auto close On, waiting time 50 seconds
ON	OFF	Auto close On, waiting time 25 seconds
ON	ON	Auto close On, waiting time 12 seconds

### Cancel auto-close function

Move the fourth and fifth DIP switches to the off position in order to disable the auto close feature.

## 14. Additional Features

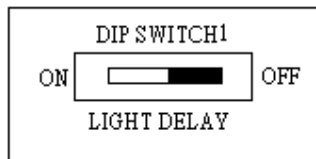

**LIGHT DELAY:** Flashing light delay on or off.  
ON: The flashing light starts 5 seconds ahead of gate moving.  
OFF: The flashing light starts and gate starts moving at same time.



**OPENING PHOTO:** When the gate is moving at opening phase, the photo sensor can be selected as active or inactive.  
ON: If photo sensor covered by the obstacle during the gate opening Phase, the gate system will stop immediately.  
OFF: If photo sensor covered by the obstacle during the gate opening phase, the gate system will not be affected by photo sensor.

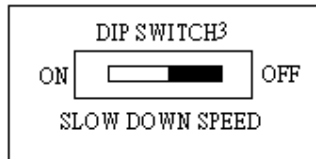

**SLOW DOWN SPEED:** The final speed can be set when the gate is moving at slow-down speed  
**ON:** The final speed = 55% normal speed.  
**OFF:** The final speed = 70% normal speed.

### **Pedestrian Start Feature:**

The System can open only one side of the gate for pedestrian traffic:

For a dual gate, connect the motor cables for both terminals J1 & J2. Press the green button of the transmitter to activate Pedestrian Start.

For single gate, connect the motor cable for terminal J1 only. Press the black button of transmitter to activate Pedestrian Start.

## **15. Operation Notes on the Gate Opener System**

When the gate is travelling at normal speed, if the motor encounters an over current condition (because of obstruction), the gate will stop immediately in opening phase but for the closing phase, the gate will stop and reverse back for approx. 2 sec.

If any command (transmitter, keypad or photocell or other abnormal case) interrupts the leaf's motion before it moves to the end of travel, the gate can only be operated with slow down speed for the rest of the cycle. The function is guaranteed for the maximum safety during the operation.

### **Kickback / extra-push**

This is usually employed to help the electric lock insertion and release during bad weather conditions (wind, ice, etc.).

### **Open / Closing delay**

#### **SM2 (slave motor) delay at opening**

System is designed for a fixed time delay (about 3 seconds) between the first gate (MM1) and the second gate (SM2) during the gate opening phase.

#### **MM1 (Master motor) delay at closing**

Delay time can be adjusted from Min 0sec to 15sec.

### **Automatic mode**

At the end of pause period, the gate will close automatically but if a new command (transmitter, keypad, photo sensor or over current) is supplied before the end of travel, this new command will cause the gate to reverse its motion.

**Stop (Reset):** If the reset switch is off, the gate systems will not work.

## 16. Maintenance & Troubleshooting

Battery overheating	Check the wiring of the battery and make sure that it is well connected and using the correct polarity.
The gate doesn't work after pressing remote control.	<ol style="list-style-type: none"> <li>1. Check if the LED used for "SLOW DOWN / POWER" is lighted.</li> <li>2. Check if the voltage of the battery is less than 10.5 VDC.</li> <li>3. Check the LED used for "push button" is lighted. Turn the power off (disconnect J7/J8) for 30 seconds, then turn it back on and repeat the learning process.</li> <li>4. Check to see if the fuse is burned out.</li> </ol>
Motor speed is slower than expected.	<ol style="list-style-type: none"> <li>1. Check to see if the gate stopped because of the push button, photo sensor, or over current (obstruction).</li> <li>2. Check to make sure that the battery and transformer J7/J8 is well connected.</li> </ol>
The gate stopped during the operation (opening or closing).	<ol style="list-style-type: none"> <li>1. Check to make sure that the Reset switch is on, and that the reset switch is well connected with terminal J6.</li> <li>2. Adjust the VR1. Re-set the over current limit at the proper position.</li> <li>3. Check the wiring of the motor is well connected.</li> <li>4. Check that the jumper for the photocell is in place or that the IR Photo Safety Sensor is in place and functioning.</li> <li>5. Check to see if the fuse is burned out.</li> </ol>
The gate doesn't work or the gate works only in one direction.	<ol style="list-style-type: none"> <li>1. Check to make sure that the Reset switch is on, and that the reset switch is well connected with the terminal J6.</li> <li>2. Check that the wiring of the motor is well connected.</li> <li>3. Check that the jumper for the photocell is in place or that the IR Photo Safety Sensor is in place and functioning.</li> </ol>

Gate "auto close" function works like "auto open"	<ol style="list-style-type: none"> <li>1. The first operation should be defined as gate closing during the learning mode no matter what the method of installation is.</li> <li>2. If the gate executes the contrary action, please swap the wiring of the motor to the opposite polarity.</li> </ol>
Gate doesn't stop immediately when it reaches the end of travel.	1. Adjust the VR1 to decrease the over current limit.
Flashing light doesn't work.	Check the wiring of the flashing light to make sure that it is well connected and using the correct polarity.
	Check that ~18V AC is present on the output side of the transformer. Check that ~14VDC is present on the terminals of the battery when the unit is plugged into AC and that at least ~12V DC is present when it is not plugged into AC but after charging.

## 17. Gatekeeper Ltd. Limited Warranty

Gatekeeper Ltd. warrants the YG-5602U/E Swinging Gate Opener to be free of defects in materials and workmanship for a period of 1 year from the date of purchase subject to certain limitations.

This warranty shall not apply in the following circumstances, misuse, vandalism, accident, neglect, unauthorized repair or modification, acts of God (lightning, flood, insect damage etc.), power surge, corrosive environments, incorrect installation or application, damage to mechanism due to wrong type of gate, incorrect weight, and gate not operating freely or not on level ground etc.

The warranty set forth here shall be entirely exclusive and no other warranty, either written or oral is expressed or implied. Gatekeeper Ltd specifically disclaims any and all implied warranties of merchantability or fitness for a particular purpose. It is the purchaser's sole and exclusive responsibility to determine whether or not the equipment will be suitable for a particular purpose. In no event shall Gatekeeper Ltd be held liable for direct, indirect, incidental, special or consequential damages or loss of profits whether based on contract, tort, or any other legal theory during the course of the warranty or at any time thereafter. The installer, purchaser and/or end user do agree to assume all responsibility for all liability in use of this product, releasing Gatekeeper Ltd of all liability.

For service under this warranty, please contact your dealer. All parts, accessories, service and support for Gatekeeper products is supplied through our network of dealers. Dealer information can be obtained at [www.gatekeeperltd.com/dealers](http://www.gatekeeperltd.com/dealers)

Gatekeeper Ltd.

P.O. Box 752

Lacey's Spring, AL 35754

[info@gatekeeperltd.com](mailto:info@gatekeeperltd.com)

For updated versions of the manual see:

<http://www.gatekeeperltd.com>

For Additional Remotes, Infrared Photo Cells or Parts please contact your

dealer. To locate a dealer, please visit us at:

[www.gatekeeperltd.com/dealers](http://www.gatekeeperltd.com/dealers)

©2005-2011 GatekeeperLtd All Rights Reserved