

TARA

keukenkast
küche schrank
cuisine cabinet
kitchen cabinet

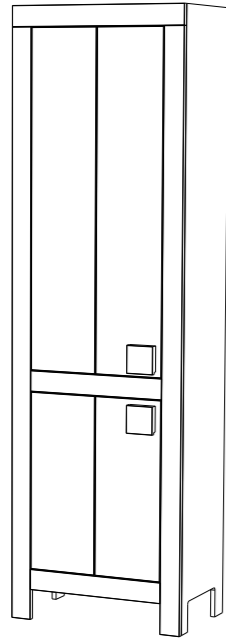

1

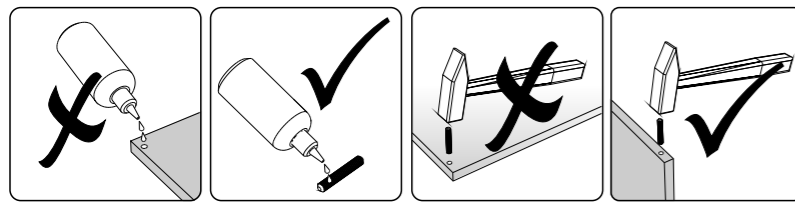
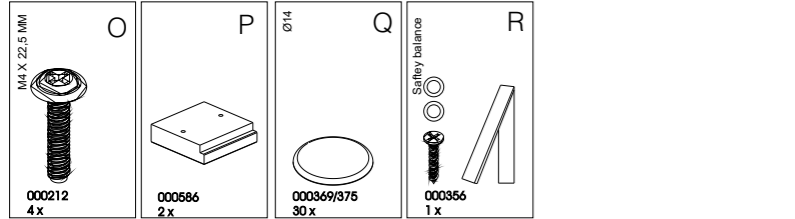
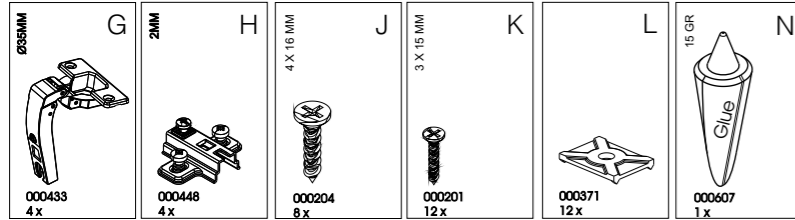
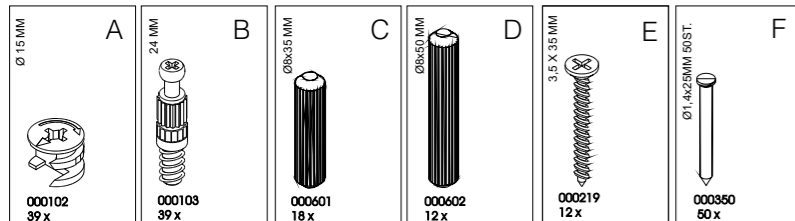
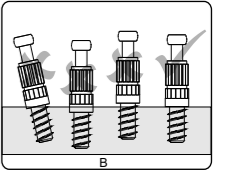
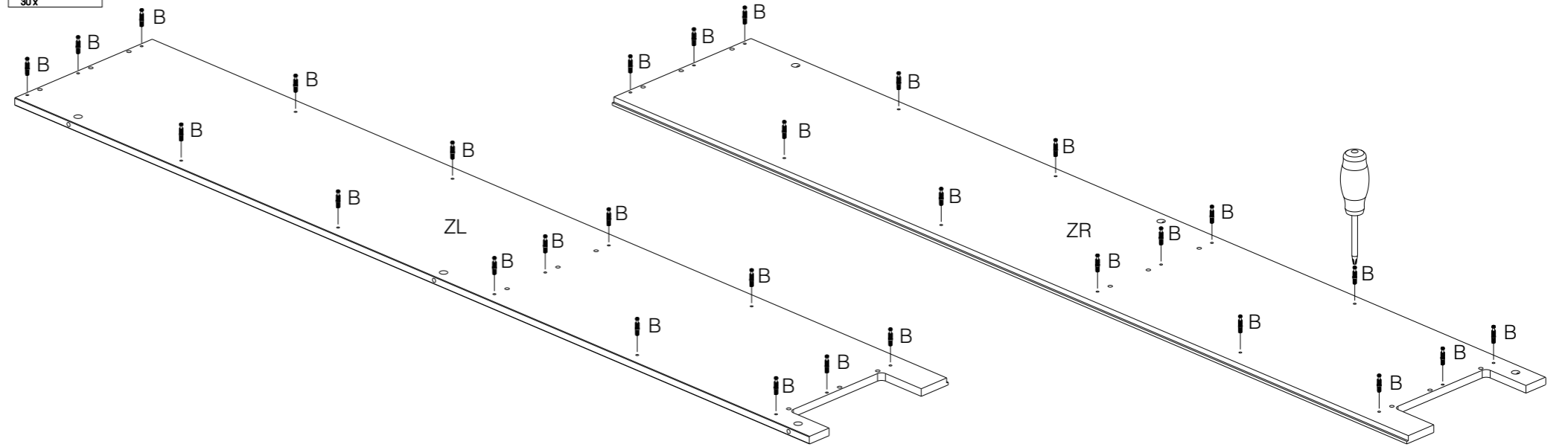
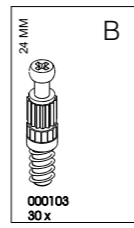

2

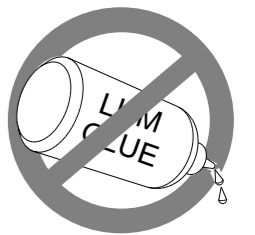
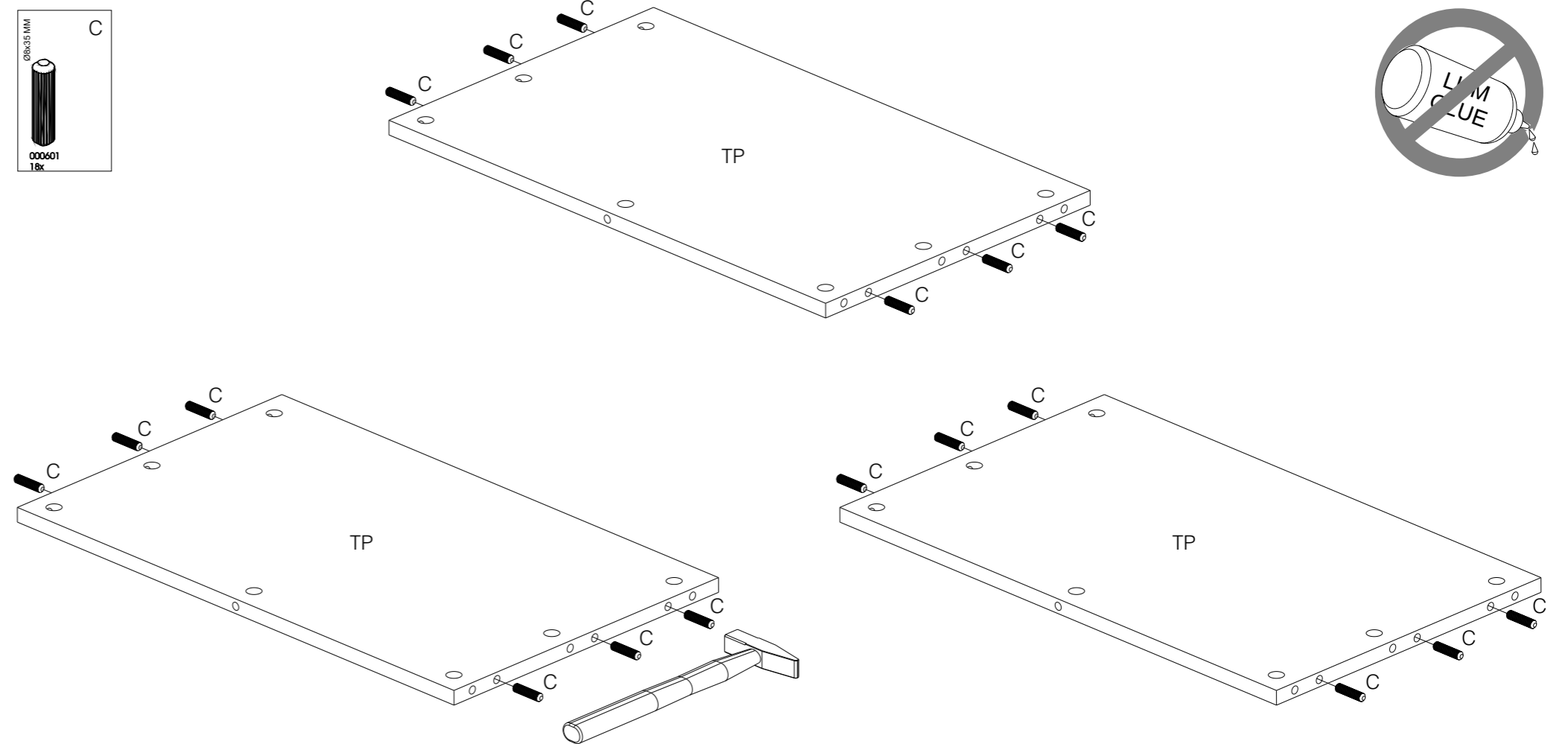
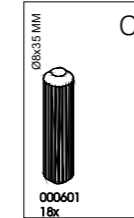

Produced by De Eekhoorn Woodworkings BV

3

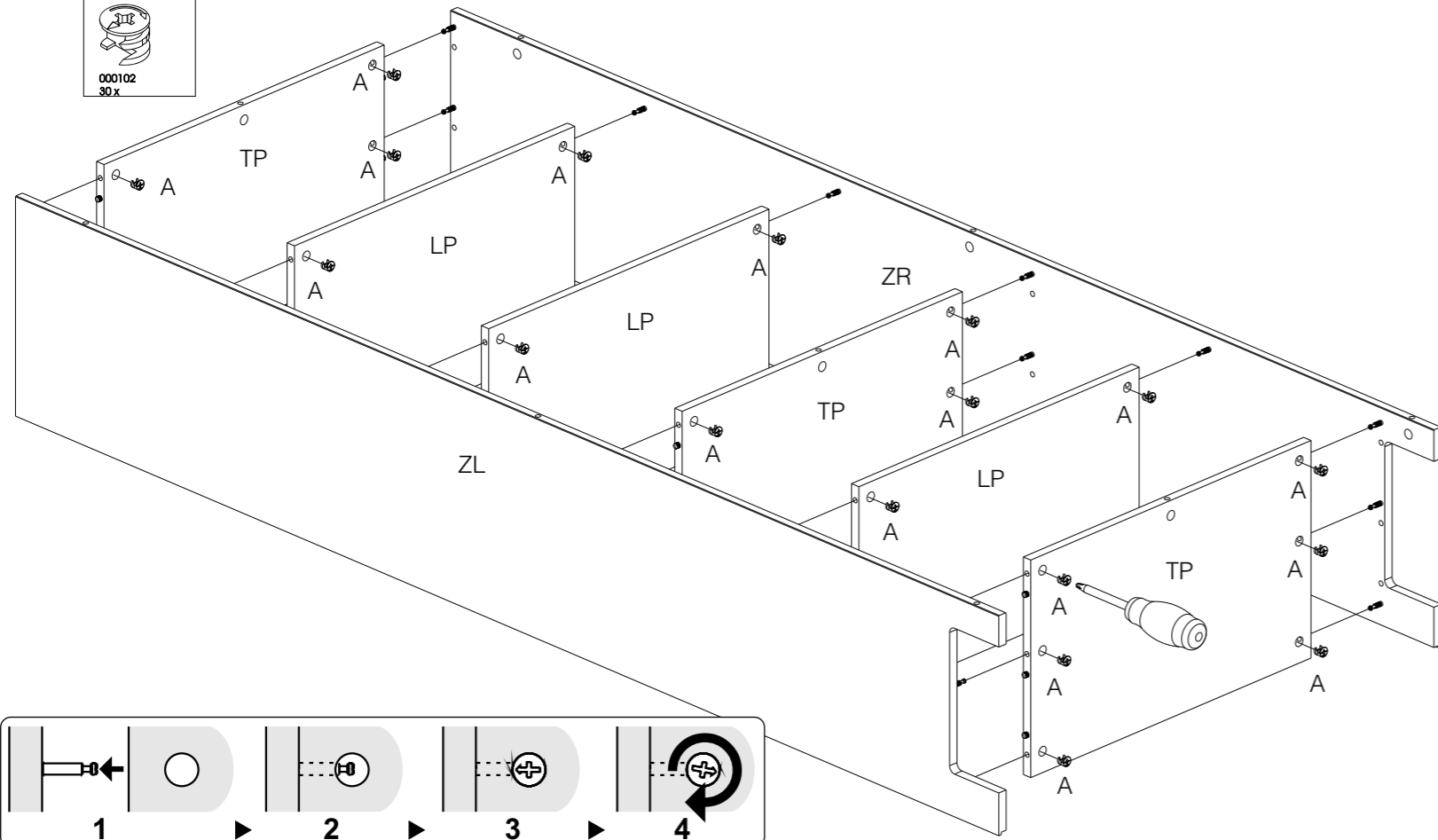
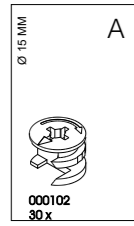

4

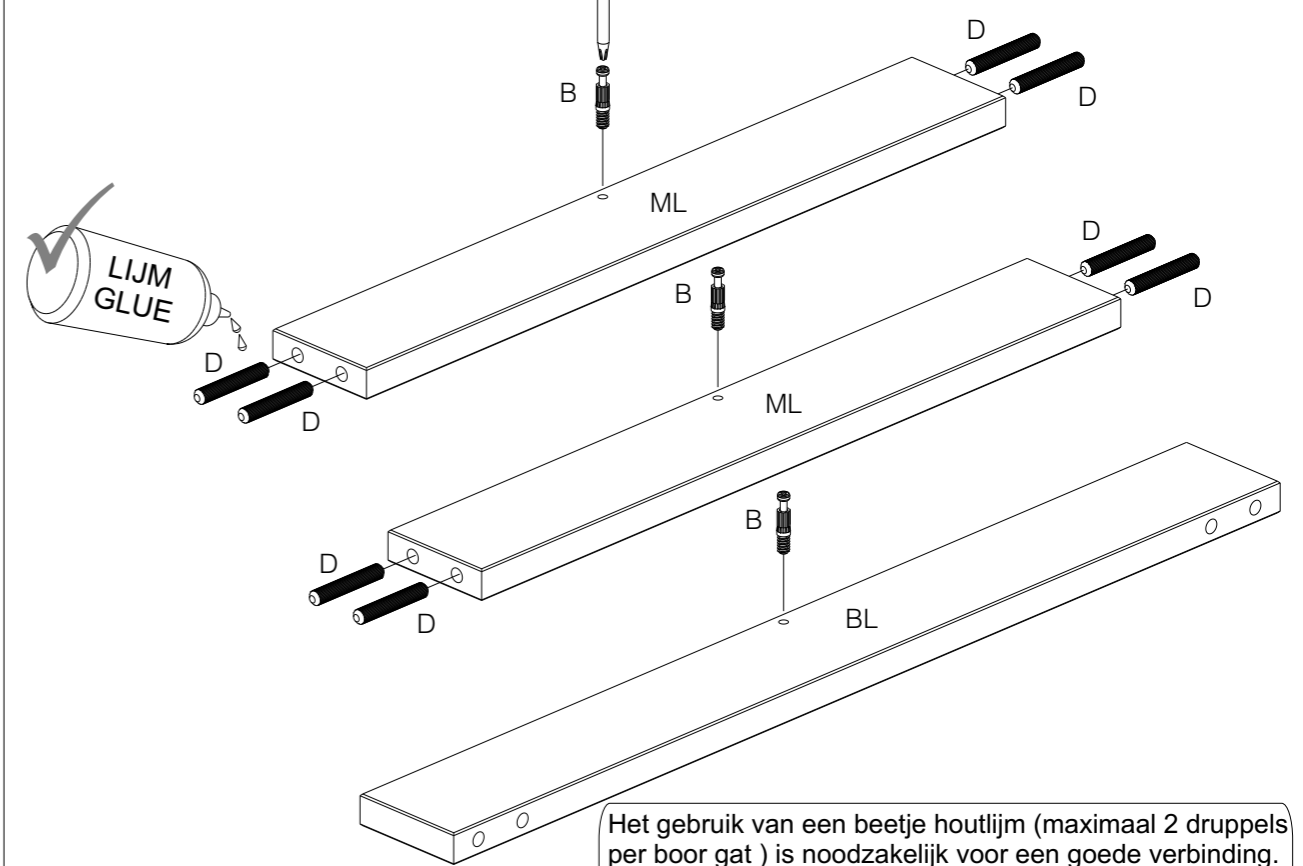
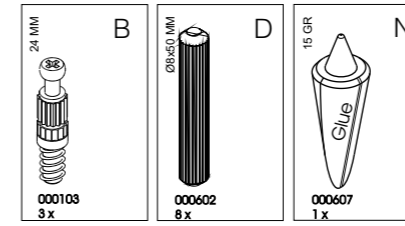

Het gebruik van een beetje houtlijm (maximaal 2 druppels per boor gat) is noodzakelijk voor een goede verbinding.

Verwendung von ein bisschen Holzleim (bis 2 tropfen pro Bohrloch) ist notwendig für eine gute Verbindung.

Il est nécessaire d'utiliser un peu de colle à bois (au maximum deux gouttes pour chaque trou de perçuse) pour assurer un bon assemblage.

The use of a little bit wood glue (up to 2 drops per drill hole) is necessary for proper connection

5

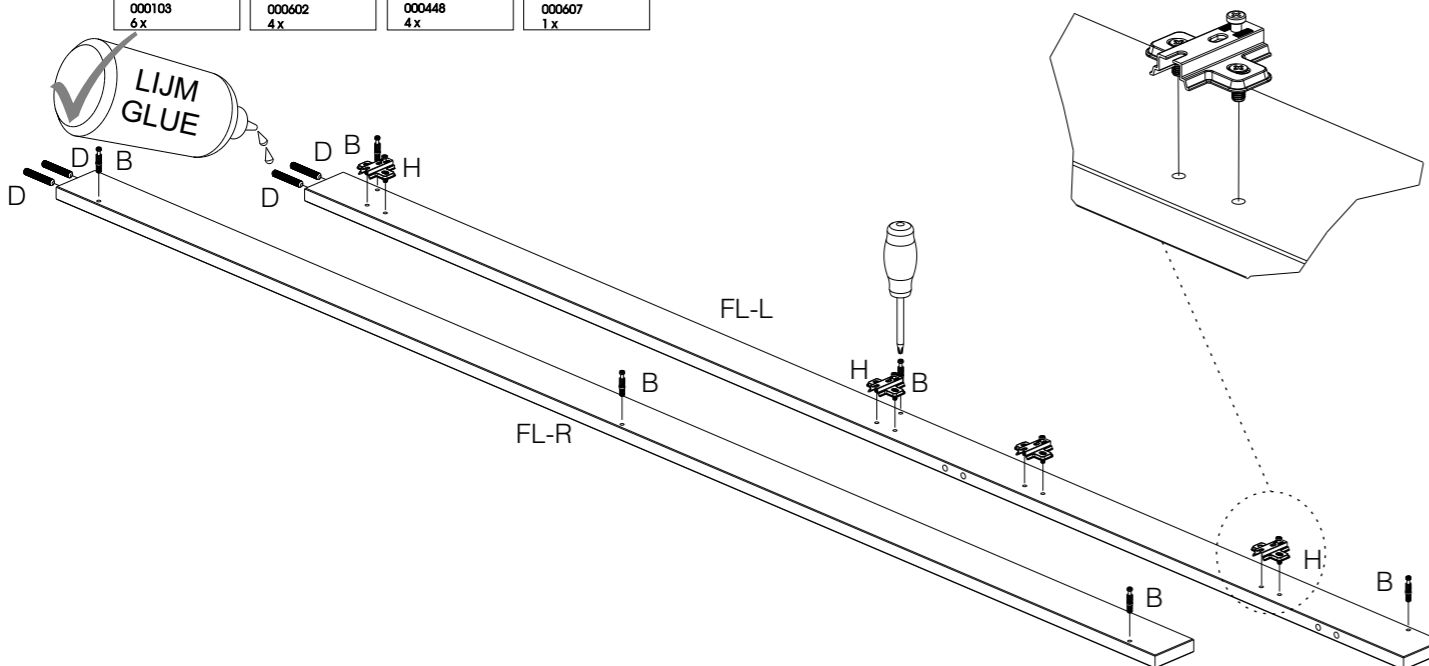
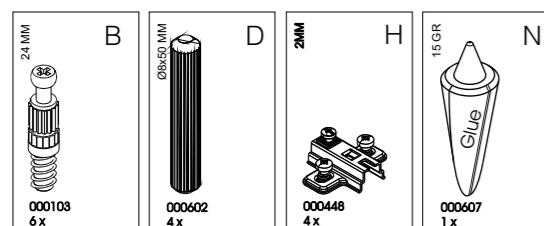

6

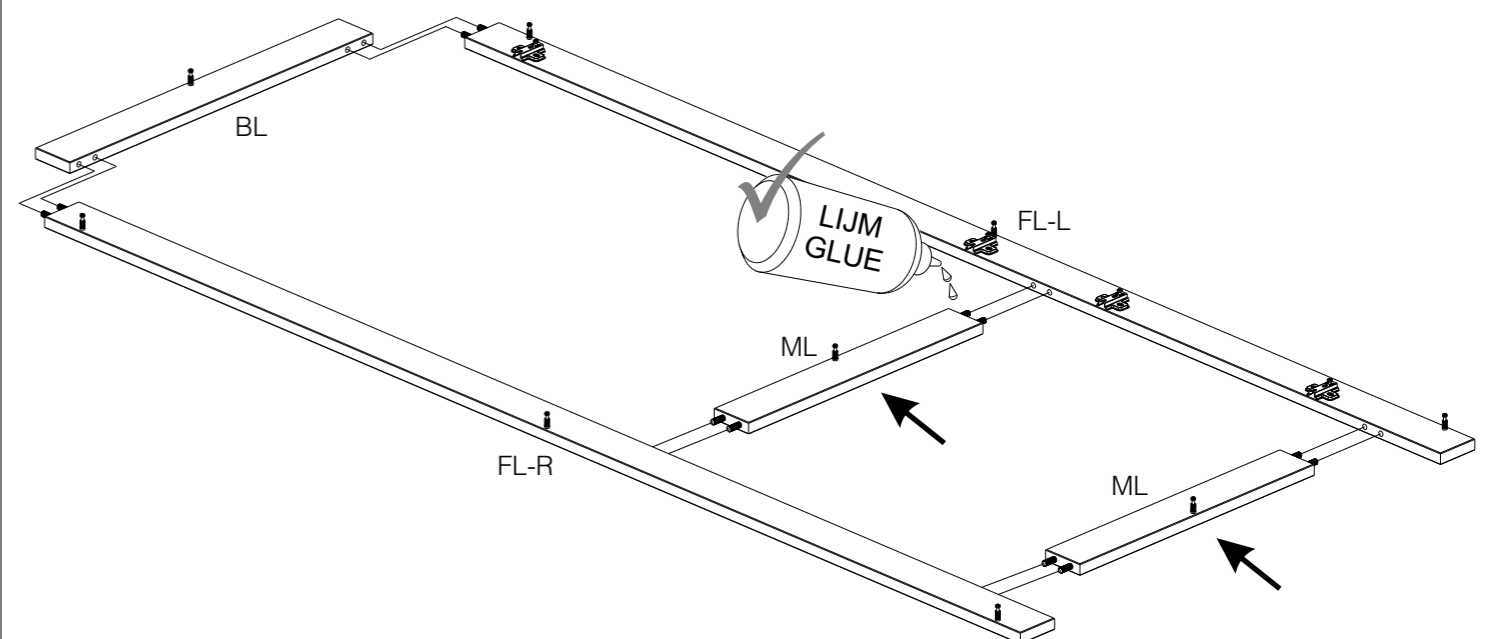
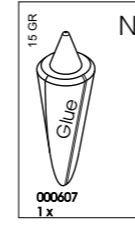

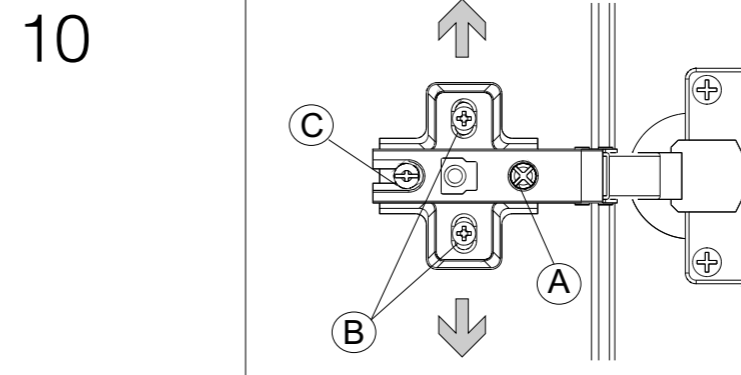
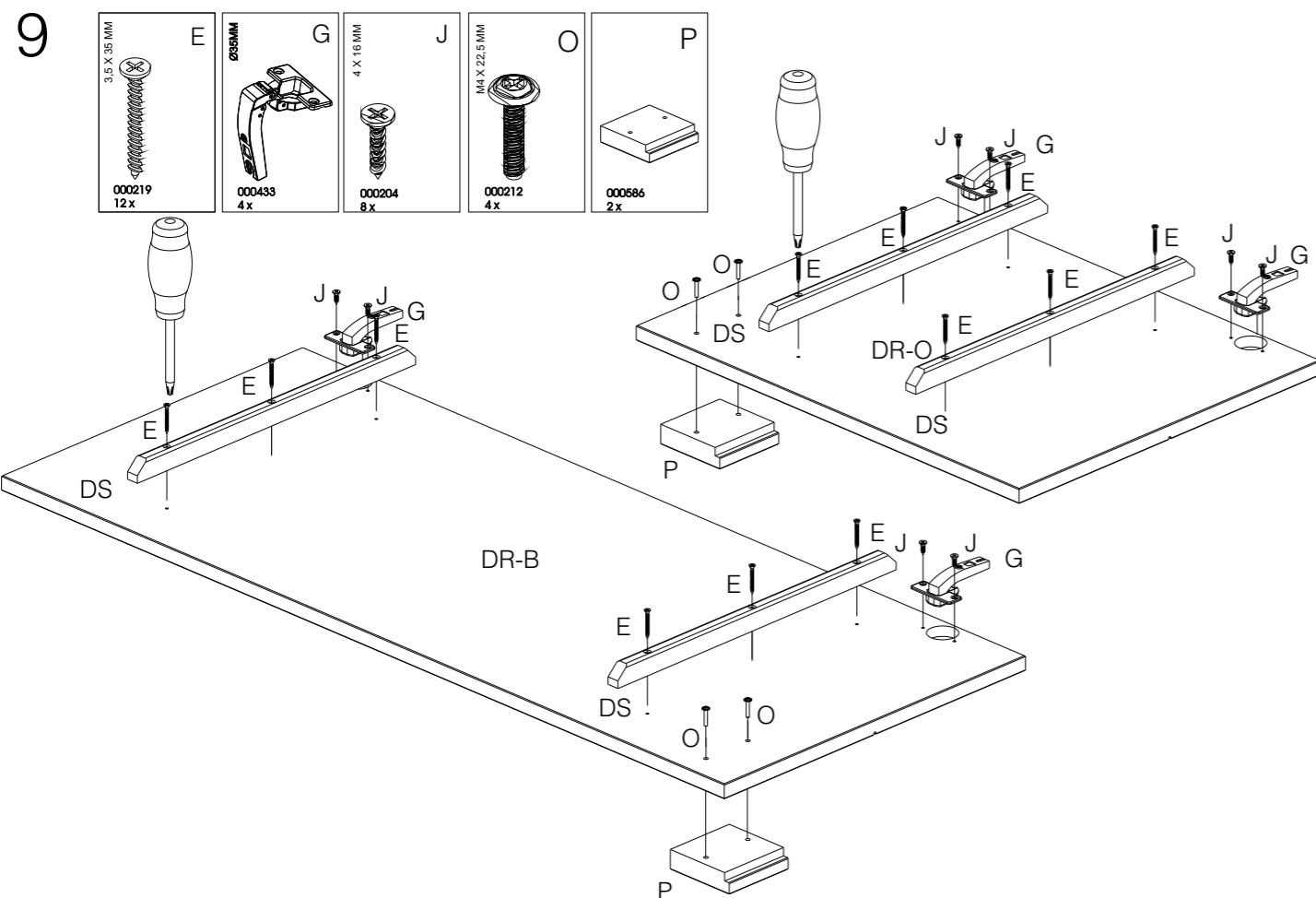
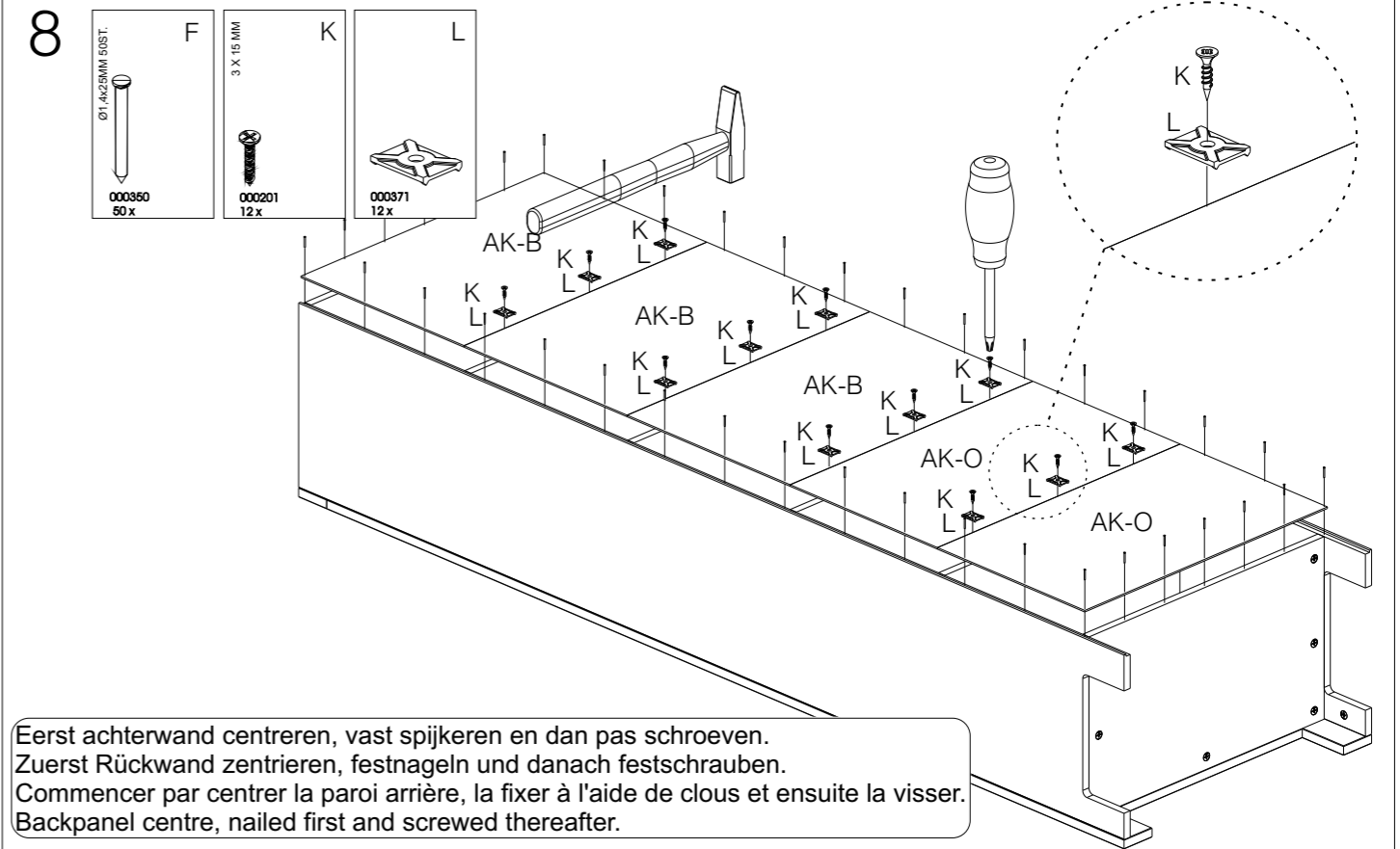
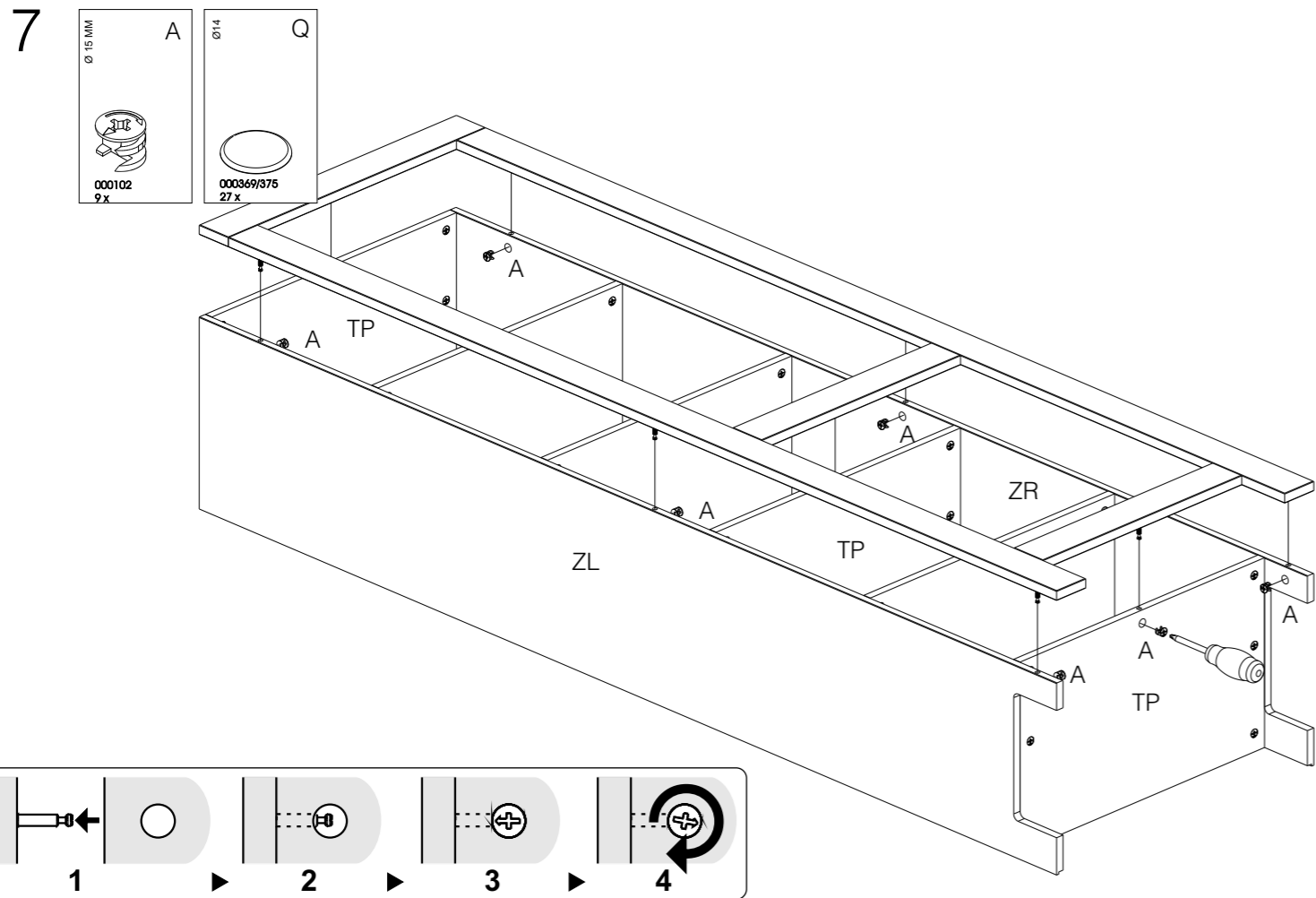

A. Met deze schroef stelt u de deur in de diepte af.
B. Door deze schroeven iets los te draaien kunt u de scharnierplaatjes verstellen zodat de deuren hoger of lager bevestigd kunnen worden.
C. Deze schroef gebruiken wanneer u de kieren tussen de deuren en beide zijden groter of kleiner wilt hebben.

A. mit dieser Schraube kann man, wenn nötig, die Tür etwas nach innen oder nach aussen drehen.
B. Wenn Sie diese Schrauben ein wenig lösen, können Sie die Scharnierplatten verstellen, um so die Tür höher oder niedriger zu befestigen.
C. Utilisez cette vis lorsque vous souhaitez augmenter ou réduire les interstices entre la porte et chacun des côtés.

A. Cette vis vous permet d'ajuster la profondeur de la porte.
B. En desserrant légèrement ces vis, vous pouvez ajuster la position des charnières pour fixer les portes plus vers le haut ou vers le bas.
C. Utilisez cette vis lorsque vous souhaitez augmenter ou réduire les interstices entre la porte et chacun des côtés.

A. With this screw you can change the depth of the doors
B. By releasing this screw the position of mounting plates of the hinges can be repositioned so that vertical position of doors can be adjusted (higher/lower)
C. Adjusting this screw will position doors horizontally (changes gap between doors)

