

Understanding and Specifying Think 465 Series Work Chairs

Product Details

Think 465 Series	54
Dimensions	58

Specifying

Work Chairs

3D Knit with Standard Upholstery on Seat	60
Standard Upholstery	62

Stools

3D Knit with Standard Upholstery on Seat	68
Standard Upholstery	70

Work Chairs

Highly adjustable task seating offers maximum personalization for fit and comfort for a range of duration and use. By making a series of simple adjustments, you can customize the chair to your body, preferences, and tasks. These chairs provide continuous, stable, comfort, and can be quickly adjusted to support you in upright, and reclining work postures.

- Gesture 442 Series
- Leap 462 Series
- Think 465 Series
- Amia 482 Series
- Reply 466 Series
- Jersey Series
- Leap 464 Series
- WorkLounge
- Criterion 453 Series

Adjustability Features

► See page 14 for a comparison to other chairs. **Think 465 Series**

Mechanisms

Weight-activated ●

Seat Adjustments

Pneumatic height ●

Passive seat edge angle ●

Seat depth ●

Back Adjustments

Lumbar height ●

Arm Adjustments

Arm height ●

Arm width ●

Arm pivot ●

Arm depth ●

Other Features

Foot ring height (stool) ●

Think 465 Series

Think is for performance based customers who are seeking a progressive aesthetic, intuitive ease of use, and the strongest environmental attributes.

Back frame and seat shell are plastic.

Lumbar height adjusts over 4 1/4" to provide additional lower back support and is available as an option.

Arm caps can pivot independently 30° in and 30° out to accommodate individual user preferences.

Comfort Dial back control provides four settings for the user's personal preference and work style.

Seat height adjusts within a 5" range with a pneumatic adjustment mechanism. A 4" or 7" range is available as an option. Stools have a 10" range.

Casters have hard, dual-wheels that roll smoothly on carpets. They are 2 1/2" for increased mobility. Soft, dual-wheel roll-control casters are available as an option for use on hard floors or chair mats.

Arm width adjusts 4 1/2" overall to support forearms in neutral position.

Arm height can adjust independently within a 4" range to help relieve upper back and shoulder fatigue.

Arm depth can retract 3" to allow user to get closer to the worksurface and into tight corners.

Passive seat edge angle allows the front edge of the seat to flex 1 1/2" to relieve pressure under the user's thighs.

Seat depth adjusts within a 2 1/2" range to accommodate users of varying leg lengths.

Five-arm base is available in plastic or polished aluminum.



Product Details

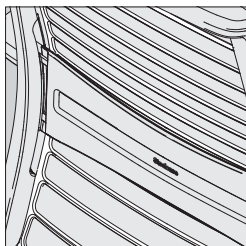

Integrated LiveBack System dynamically supports and follows the movements of the user.

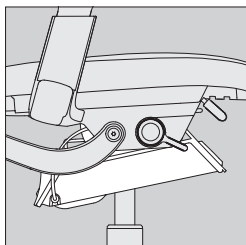

Advanced weight-activated mechanism with a natural fluid motion keeps users oriented to their work.

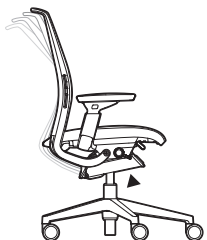

Comfort dial has four settings that allow for the user's personal preference and work style.

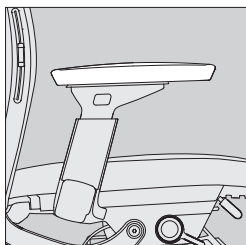

Rectilinear arms with foot caps are standard.

Cartoned request on your dealer purchase order means Think chairs will ship knocked down with the chair base and pneumatic cylinder separated from the rest of the chair. This allows for shipment in a smaller carton. Assembly by a qualified dealer installer is required. *Tip: Assembly instructions are included.*

Uncartoned request on your dealer purchase order means Think chairs will ship fully assembled.

Adjustment Features

► **Adjustability instructions** are included with every chair.

Seat Adjustments

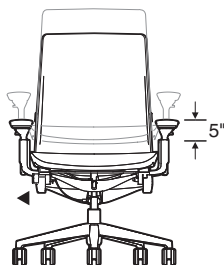

Seat height adjusts pneumatically. To lower, hold handle up while seated. To raise, hold handle up and keep your weight off the chair. Standard range of adjustability is 5" from 16 1/2"H to 21 1/2"H. A 4" range of adjustability (15"H to 19"H), and a 7" range of adjustability (18"H to 25"H) is available as an option. A 10" range of adjustability (22 1/2"H to 32 1/2" H) is available on stools.

Passive seat edge angle relieves pressure under the user's thighs. The passive front seat edge helps properly support the angle of the user's leg and thigh without compromising pelvic support. The front seat edge angle flexes 1 1/2".

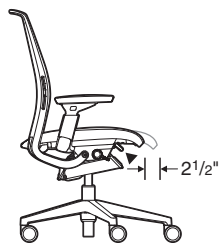

Seat depth adjusts 2 1/2" (15 1/2"–18") by pulling handle up. Slide seat forward or back to accommodate various leg lengths. Release handle to lock.

Back Adjustments

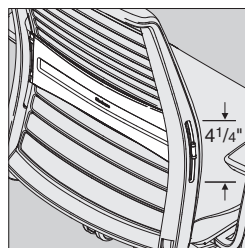

Lumbar height adjusts 4 1/4" (6" to 10 1/4" from seat) by grabbing exposed tabs and sliding the lumbar support up or down. Fixed lumbar height is available as an option on work chairs and stools.



Weight-activated setting

Boosted setting



Mid-stop recline setting

Upright setting

Comfort Dial has four settings: (1) weight-activated setting; (2) boosted setting that has approximately 20% more resistance than your body is providing; (3) mid-stop recline setting; and (4) an upright setting.

Arm Adjustments

Rectilinear height-, width-, pivot-, and depth-adjustable arms come standard on all arm models of chairs and stools.

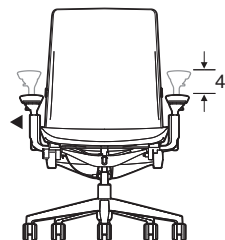

Arm height adjusts independently within a range of 4" (7"–11" from the seat). Push button on outside and under arm cap in while moving arms up or down. Releasing buttons locks arms in position.

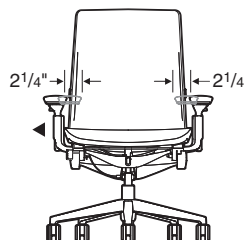

Arm width can be adjusted 2 1/4" each, 4 1/2" overall. Grasp arm cap and move in or out.

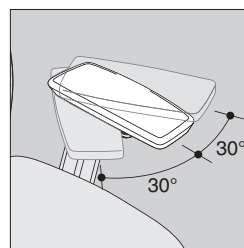

Arms pivot independently, 30° inward and outward. Grasp arm and push front to left or right.

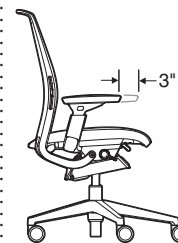

Arm depth adjusts by sliding arm caps back 3". Friction-fit mechanism keeps arms in position.

Other Features

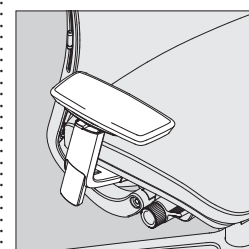

Height-only adjustable arm is also available and adjusts 4".



Armless models are also available.

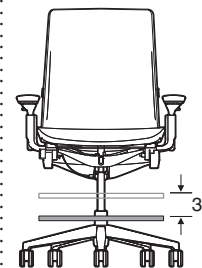

Foot ring height on stools adjusts by rotating it counterclockwise to unlock. Then raise or lower ring to desired position before rotating it clockwise to lock. The foot ring has a diameter of 20".

Soft dual-wheel roll-control casters feature an internal brake that activates when the chair is not under load to reduce shifting when user stands up.

Surface Materials

▶ See surface materials on page 310 for specific availability or refer to the *Surface Materials Reference Manual* for further information.

Upholstery

- Fabric
- Fabric with soil-retardant treatment (option)
- 3D Knit (back only)
- Elmosoft leather
- Leather
- Vinyl

Hard components

All models (backframe, arm retainer, and base)

- 4799 Platinum Metallic
- 6205 Black
- 7243 Seagull

Pneumatic cylinders and stool ring finishes are determined by the frame finish.

- 4799 Platinum Metallic (Platinum & Seagull frame)
- 6205 Black (Black frame)

All Models (adjustment handles, arm pads, arm stalk, casters)

- 6205 Black

Flexors and lumbar finishes are determined by the frame finish.

- 6205 Black (Black Frame)
- 6527 Merle (Platinum and Seagull Frames)

Outer seat shell is determined by the frame finish.

- 6205 Black (Black Frame)
- 6249 Platinum Solid (Platinum and Seagull Frames)

Inner seat shell.

- 6205 Black

All seat cushions have a unique sewn construction that is included in the price of the chair.



Stitch detail across the lumbar region of the back cushion will be required on some models with an upholstered backrest. To ensure optimum performance of the Integrated LiveBack System, all Steelcase Select Surfaces, COMs, Leathers, Vinyls, and some standard fabrics will require this sewn detail. The stitch detail is included in the price of the chair.

All Steelcase seating with standard upholstery fabrics complies with requirements of the State of California Technical Bulletin 117. All standard seating is labeled to be in compliance with California 117.

Programs & Services

▶ See *Surface Materials Reference Manual* for further detail about programs and services offered for seating.

The Customer's Own Material (COM)

Program offers the opportunity for customers to select fabrics that are not offered through the standard Steelcase surface materials program for use on Steelcase products. Through the COM program, Steelcase will test your materials for application on Steelcase products.

Once approved, you can place your order. Steelcase will facilitate the entire ordering process and give you a production schedule.

Steelcase will order the COM fabric directly from the textile manufacturer. For up-to-date information regarding fabric test results for all COM fabrics and details regarding yardage requirements for most seating lines, visit the COM Web site. To locate the COM Web site:

- Visit www.steelcase.com

Soil retardants are treatments that provide long-term soil and stain resistance to a fabric without affecting the shade or the integrity of the fabric. The following Steelcase Textiles are available pre-treated with soil retardant. (You do not need to select the soil-retardant option for these fabrics and incur the upcharge.)

- Jacks
- Link
- Spyder

For information on soil retardant fabrics on Select Surfaces, please refer to the *Surface Materials Reference Manual*.

Soil-retardant treatment is available on all other seating fabrics at an additional upcharge per seating unit. To order this option, please select "Soil-Retardant Treatment" under "Optional Accessories."

For soil-retardant treatment on COMs, please select "Soil-Retardant Treatment" under "Optional Accessories." Minimums or additional yardage may be required. Please contact the vendor directly for specific information.

Extended lead times may be necessary for this service.

Contact your Steelcase Solutions Fulfillment Team Representative at 1.888.STEELCASE (1.888.783.3522) or send an email to lineone@steelcase.com.

Fire Codes

▶ See pages 316–317 for upholstery fabrics available for use with FCS modification.

Steelcase offers Fire Code Seating modification (FCS) on nearly all seating models. The most rigorous fire codes in the nation have been developed in California, and the Steelcase FCS modification is designed to meet those codes. Fire Code Seating (FCS) indicates that a product is constructed to meet the strict fire code requirements of high public occupancy areas such as theaters, meeting rooms, and lobbies. The FCS standards will meet both the State of California Home Furnishing Technical Bulletin 133 (Cal TB 133) and Boston Fire Code (BFC). Boston adopted the California Home Furnishing Technical Bulletin TB 133 test standard in 1992.

Local codes may have special requirements for upholstery.

Dimensions

▶ Page 58

What Is It?

Fabric, leather, or vinyl-covered back and seat, 3D Knit back.

Fabric

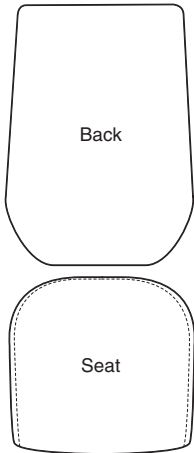

Leather, Vinyl, and Select Other Fabrics

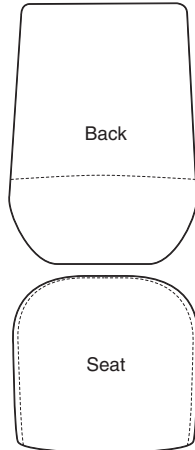

3D Knit on Back only

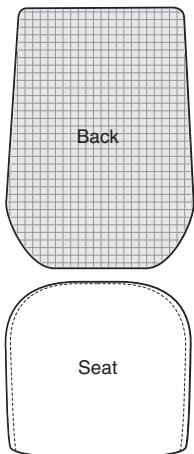

Stitched seams are included on the back cushion and seat cushion of the following:

- Leather
- Vinyl
- Some upholstery
- Customer's Own Leather (COL)
- Vinyl
- Select Customer's Own Material/Vinyl (COM)

Pattern alignment at the lumbar seam cannot be guaranteed.

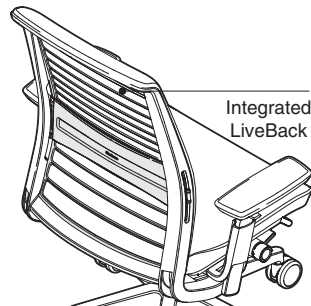

Back Flexors are fully exposed.

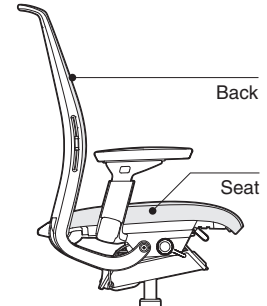

Seat and back assemblies can be removed and replaced if damaged.

Dimensions

Think 465 Series

Features	Overall Depth	Width	Height	Seat Depth	Functional Seat Depth	Seat Width	Seat Height from Floor	Back Width	Back Height from Seat	Lumbar Height from Seat
----------	---------------	-------	--------	------------	-----------------------	------------	------------------------	------------	-----------------------	-------------------------

Think 465 Series

Chairs

Arms	22" to 24 1/4"	28 1/2"	37 1/4" to 42"	18 1/2"	15 1/2" to 18"	20 1/4"	16 1/2" to 21 1/2" (15" to 19", 18" to 25" optional)	18"	22 3/4"	6" to 10 1/4"
------	----------------	---------	----------------	---------	----------------	---------	---	-----	---------	---------------

Stools

Arms	22" to 24 1/4"	28 1/2"	44" to 53 3/4"	18 1/2"	15 1/2" to 18"	20 1/4"	22 1/2" to 32 1/2"	18"	22 3/4"	6" to 10 1/4"
------	----------------	---------	----------------	---------	----------------	---------	--------------------	-----	---------	---------------

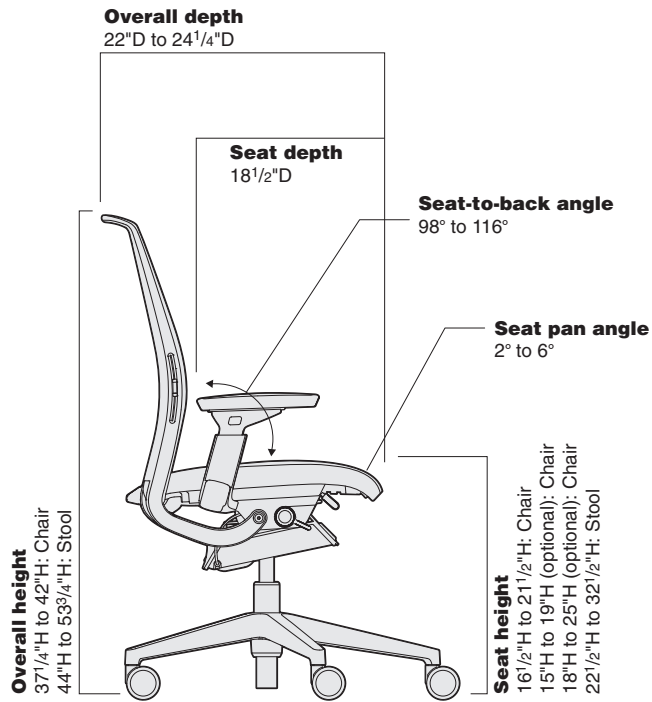
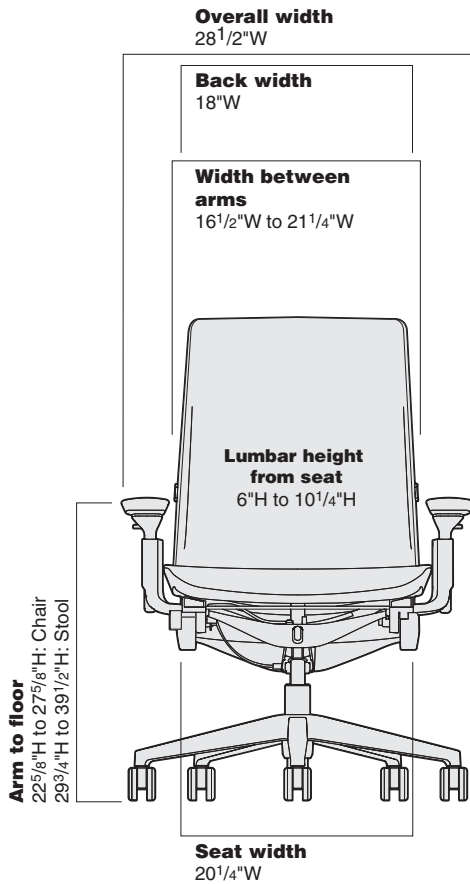

• Width • Between • Adjustable • Arms	• Width • Between • Fixed • Arms	• Arm • to • Floor	• Arm • Height • from • Seat	• Arm • Height • from Seat • for Fixed • Arms	• Arm Cap • Pivot • Range	• Angle • Between • Seat and • Back	• Seat • Pan • Angle
--	---	--------------------------	---------------------------------------	---	---------------------------------	--	----------------------------

Chairs

16½" to 21¼" 14" to 21¼" (including pivot)	20½"	22⅝" to 27⅝"	7" to 11"	8¼"	30° inward, 30° outward	98° to 116°	2° to 6°
--	------	--------------	-----------	-----	----------------------------	-------------	----------

Stools

16½" to 21¼" 14" to 21¼" (including pivot)	20½"	29¾" to 39½"	7" to 11"	8¼"	30° inward, 30° outward	98° to 116°	2° to 6°
--	------	--------------	-----------	-----	----------------------------	-------------	----------

Think 465 Series Work Chairs

3D Knit with Standard Upholstery on Seat



	Standard Includes	Required to Specify
<ul style="list-style-type: none"> ▶ Need help? Product details, page 54 	<ul style="list-style-type: none"> • 5" pneumatic seat-height adjustment (16½"-21½") • Passive seat edge angle • Frame, seat shell, and five-arm plastic base: black • 2½" seat depth adjustment • Rectilinear height-, width-, pivot-, and depth-adjustable arms • Adjustable lumbar • 3D Knit on back • Standard upholstery design on seat: fabric price group 1 • 2½"-diameter, hard-composition, dual-wheel casters: black 	<ol style="list-style-type: none"> 1 Style number 2 Plastic color for frame, base, and arm retainer 3 3D Knit color for back 4 Fabric color number for upholstery on seat 5 Options, if selected (see below) <ul style="list-style-type: none"> ▶ See <i>Surface Materials</i>, page 310.

	Options	U.S. Price	Required to Specify
Surface Materials	Upholstery		
	• Fabric price group 1	No cost	Specify fabric color number.
	• Fabric price group 2	+\$ 10	Specify fabric color number.
	• Fabric price group 3	+\$ 24	Specify fabric color number.
	• Fabric price group 4	+\$ 33	Specify fabric color number.
	• Fabric price group 5	+\$ 40	Specify fabric color number.
	• Fabric price group 6	+\$ 49	Specify fabric color number.
	• Fabric price group 7	+\$ 59	Specify fabric color number.
	• Fabric price group 8	+\$ 73	Specify fabric color number.
	• Fabric price group 9	+\$ 90	Specify fabric color number.
	• Fabric price group 10	+\$103	Specify fabric color number.
	• Steelcase leather upholstery	+\$163	Specify leather color number.
	• Elmosoft leather upholstery	+\$187	Specify Elmosoft leather color number.
	• Customer's Own Material (COM)	No cost	▶ See <i>Surface Materials Reference Manual</i> .
	• Soil-retardant treatment applied to upholstery fabric	+\$ 23	Specify with soil-retardant treatment.
	Frame		
	• Platinum	+\$ 50	Specify with 4799 Platinum.
	• Seagull	+\$ 50	Specify with 7243 Seagull.
Arms	• Height-adjustable arms	-\$ 48	Specify with height-adjustable arms.
	• Fixed arms	-\$ 96	Specify with fixed arms.
	• Armless	-\$245	Specify without arms.
Base	• Polished aluminum base	+\$136	Specify with aluminum base.
Seat Height	• 4" pneumatic seat-height adjustment (15"-19")	+\$ 56	Specify with 4" pneumatic seat-height adjustment.
	• 7" pneumatic seat-height adjustment (18"-25")	+\$ 56	Specify with 7" pneumatic seat-height adjustment.
Lumbar	• Fixed lumbar support	-\$ 55	Specify with fixed lumbar height.
Casters	• Soft, dual-wheel roll-control casters for use on hard floors	+\$ 23	Specify with soft roll-control casters.

Specification Information

Style Number	U.S. Base Price
465A300	\$1215

▶ Detailed dimensions, page 58



For Canadian Pricing

Multiply U.S. Price by the Canadian price factor.

▶ See page 1 for details.

Think 465 Series Work Chairs

Standard Upholstery on Back and Seat

Think 465 Series
Work Chairs



	Standard Includes	Required to Specify
▶ Need help? Product details, page 54	<ul style="list-style-type: none"> • 5" pneumatic seat-height adjustment (16½"–21½") • Passive seat edge angle • Frame, seat shell, and five-arm plastic base: black • 2½" seat depth adjustment • Rectilinear height-, width-, pivot-, and depth-adjustable arms • Adjustable lumbar • Standard upholstery design: fabric price group 1 • 2½"-diameter, hard-composition, dual-wheel casters: black 	<ol style="list-style-type: none"> 1 Style number 2 Plastic color for frame, base, and arm retainer 3 Fabric color number for upholstery on seat and back 4 Options, if selected (see below) <p>▶ See <i>Surface Materials</i>, page 310.</p>

	Options	U.S. Price	Required to Specify
Surface Materials	Upholstery		
	• Fabric price group 1	No cost	Specify fabric color number.
	• Fabric price group 2	+\$ 24	Specify fabric color number.
	• Fabric price group 3	+\$ 46	Specify fabric color number.
	• Fabric price group 4	+\$ 64	Specify fabric color number.
	• Fabric price group 5	+\$ 81	Specify fabric color number.
	• Fabric price group 6	+\$100	Specify fabric color number.
	• Fabric price group 7	+\$115	Specify fabric color number.
	• Fabric price group 8	+\$145	Specify fabric color number.
	• Fabric price group 9	+\$179	Specify fabric color number.
	• Fabric price group 10	+\$203	Specify fabric color number.
	• Steelcase leather upholstery	+\$318	Specify leather color number.
	• Elmosoft leather upholstery	+\$368	Specify Elmosoft leather color number.
	• Customer's Own Material (COM)	No cost	▶ See <i>Surface Materials Reference Manual</i> .
• Soil-retardant treatment applied to upholstery fabric	+\$ 23	Specify <i>with soil-retardant treatment</i> .	
	Frame		
	• Platinum	+\$ 50	Specify <i>with 4799 Platinum</i> .
	• Seagull	+\$ 50	Specify <i>with 7243 Seagull</i> .
Arms	• Height-adjustable arms	–\$ 48	Specify <i>with height-adjustable arms</i> .
	• Fixed arms	–\$ 96	Specify <i>with fixed arms</i> .
	• Armless	–\$245	Specify <i>without arms</i> .
Base	• Polished aluminum base	+\$136	Specify <i>with aluminum base</i> .
Seat Height	• 4" pneumatic seat-height adjustment (15"–19")	+\$ 56	Specify <i>with 4" pneumatic seat-height adjustment</i> .
	• 7" pneumatic seat-height adjustment (18"–25")	+\$ 56	Specify <i>with 7" pneumatic seat-height adjustment</i> .
Lumbar	• Fixed lumbar support	–\$ 55	Specify <i>with fixed lumbar height</i> .
Casters	• Soft, dual-wheel roll-control casters for use on hard floors	+\$ 23	Specify <i>with soft roll-control casters</i> .

Specification Information

Style Number	U.S. Base Price
465A000	\$1159

▶ Detailed dimensions, page 58



For Canadian Pricing

Multiply U.S. Price by the Canadian price factor.

▶ See page 1 for details.

Think 465 Series Stool

3D Knit with Standard Upholstery on Seat



	Standard Includes	Required to Specify
<p>► Need help? Product details, page 54</p>	<ul style="list-style-type: none"> • 10" pneumatic seat-height adjustment (22½"-32½") • Passive seat edge angle • Frame, seat shell, and five-arm base: black • 2½" seat depth adjustment • Rectilinear height-, width-, pivot-, and depth-adjustable arms • Column and adjustable foot ring: black • Adjustable lumbar • 3D Knit on back • Standard upholstery design on seat: fabric price group 1 • 2½"-diameter, hard-composition, dual-wheel casters: black 	<ol style="list-style-type: none"> 1 Style number 2 Plastic color for frame, base, and arm retainer 3 3D Knit color for back 4 Fabric color number for upholstery on seat 5 Options, if selected (see below) <p>► See <i>Surface Materials</i>, page 310.</p>

	Options	U.S. Price	Required to Specify
Surface Materials	Upholstery		
	• Fabric price group 1	No cost	Specify fabric color number.
	• Fabric price group 2	+\$ 10	Specify fabric color number.
	• Fabric price group 3	+\$ 24	Specify fabric color number.
	• Fabric price group 4	+\$ 33	Specify fabric color number.
	• Fabric price group 5	+\$ 40	Specify fabric color number.
	• Fabric price group 6	+\$ 49	Specify fabric color number.
	• Fabric price group 7	+\$ 59	Specify fabric color number.
	• Fabric price group 8	+\$ 73	Specify fabric color number.
	• Fabric price group 9	+\$ 90	Specify fabric color number.
	• Fabric price group 10	+\$103	Specify fabric color number.
	• Steelcase leather upholstery	+\$163	Specify leather color number.
	• Elmosoft leather upholstery	+\$187	Specify Elmosoft leather color number.
• Customer's Own Material (COM)	No cost	► See <i>Surface Materials Reference Manual</i> .	
• Soil-retardant treatment applied to upholstery fabric	+\$ 23	Specify with soil-retardant treatment.	
	Frame		
	• Platinum	+\$ 50	Specify with 4799 Platinum.
	• Seagull	+\$ 50	Specify with 7243 Seagull.
Arms	• Height-adjustable arms	-\$ 48	Specify with height-adjustable arms.
	• Fixed arms	-\$ 96	Specify with fixed arms.
	• Armless	-\$245	Specify without arms.
Base	• Polished aluminum base	+\$136	Specify with aluminum base.
Lumbar	• Fixed lumbar support	-\$ 55	Specify with fixed lumbar height.
Casters	• Soft, dual-wheel roll-control casters for use on hard floors	+\$ 23	Specify with soft roll-control casters.

Specification Information	
• Style Number	• U.S. Base Price
465B300	\$1454
.	.
.	.

► Detailed dimensions, page 58



For Canadian Pricing

Multiply U.S. Price by the Canadian price factor.

► See page 1 for details.

Think 465 Series Stool

Standard Upholstery on Back and Seat

Think 465 Series Stool



	Standard Includes	Required to Specify
▶ Need help? Product details, page 54	<ul style="list-style-type: none"> • 10" pneumatic seat-height adjustment (22½"–32½") • Passive seat edge angle • Frame, seat shell, and five-arm base: black • 2½" seat depth adjustment • Rectilinear height-, width-, pivot-, and depth-adjustable arms • Column and adjustable foot ring: black • Adjustable lumbar • Standard upholstery design: fabric price group 1 • 2½"-diameter, hard-composition, dual-wheel casters: black 	<ol style="list-style-type: none"> 1 Style number 2 Plastic color for frame, base, and arm retainer 3 Fabric color number for upholstery on seat and back 4 Options, if selected (see below) <p>▶ See <i>Surface Materials</i>, page 310.</p>

	Options	U.S. Price	Required to Specify
Surface Materials	Upholstery		
	• Fabric price group 1	No cost	Specify fabric color number.
	• Fabric price group 2	+\$ 24	Specify fabric color number.
	• Fabric price group 3	+\$ 46	Specify fabric color number.
	• Fabric price group 4	+\$ 64	Specify fabric color number.
	• Fabric price group 5	+\$ 81	Specify fabric color number.
	• Fabric price group 6	+\$100	Specify fabric color number.
	• Fabric price group 7	+\$115	Specify fabric color number.
	• Fabric price group 8	+\$145	Specify fabric color number.
	• Fabric price group 9	+\$179	Specify fabric color number.
	• Fabric price group 10	+\$203	Specify fabric color number.
	• Steelcase leather upholstery	+\$318	Specify leather color number.
	• Elmosoft leather upholstery	+\$368	Specify Elmosoft leather color number.
• Customer's Own Material (COM)	No cost	▶ See <i>Surface Materials Reference Manual</i> .	
• Soil-retardant treatment applied to upholstery fabric	+\$ 23	Specify with soil-retardant treatment.	
	Frame		
	• Platinum	+\$ 50	Specify with 4799 Platinum.
	• Seagull	+\$ 50	Specify with 7243 Seagull.
Arms	• Height-adjustable arms	–\$ 48	Specify with height-adjustable arms.
	• Fixed arms	–\$ 96	Specify with fixed arms.
	• Armless	–\$245	Specify without arms.
Base	• Polished aluminum base	+\$136	Specify with aluminum base.
Lumbar	• Fixed lumbar support	–\$ 55	Specify with fixed lumbar height.
Casters	• Soft, dual-wheel roll-control casters for use on hard floors	+\$ 23	Specify with soft roll-control casters.

Specification Information	
Style Number	U.S. Base Price
465B000	\$1398

▶ Detailed dimensions, page 58



For Canadian Pricing
Multiply U.S. Price by the Canadian price factor.
▶ See page 1 for details.

