

Assembly Instruction Sheet for Item No. 655-2X Nassau Coffee Table

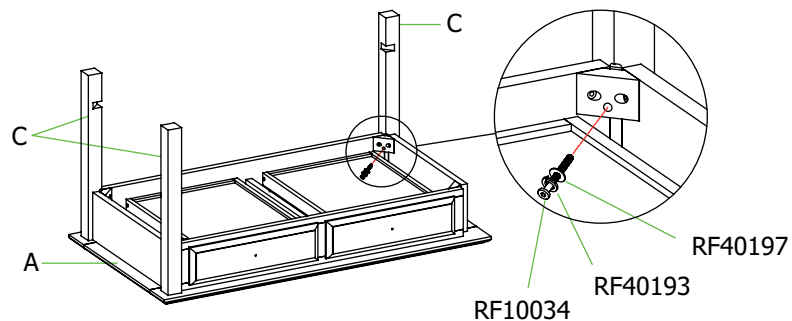
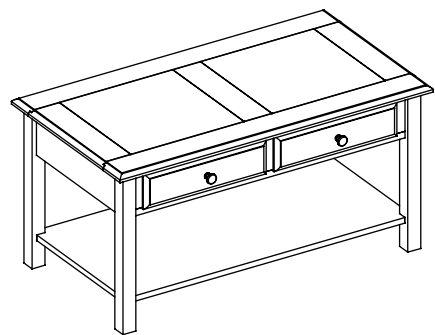

Diagram 1.

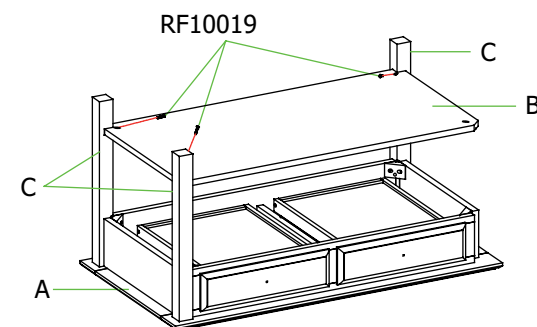

Diagram 2.

LIST OF WOODEN PARTS

NO	DESCRIPTION	Q'TY
A	TABLE TOP SET	1
B	SHELF	1
C	LEGS	4

Step 1. Lay the table top set(A) on a soft surface. Be careful drawer **OPEN!** Attach 3 lags(C) into the table top set(A) using screws JCB M6 x 50 mm(RF10034), 3 Spring washers(RF40193) and 3 washers(RF40197) as per Diag. 1.

Step 2. Attach the bottom shelf(B) into the 3 legs(C) using 3 screws F6 x 1"(RF10019) as per Diag. 2.

LIST OF HARDWARE

NO	DESCRIPTION	Q'TY
RF40170	HANDLE KNOBS	2
RF10034	SCREWS JCB M6 x 50 mm.	4
RF40193	SPRING WASHERS	4
RF40197	WASHERS	4
RF10019	SCREWS F6 x 1"	4
RF40015	HEXAGONAL WRENCH	1

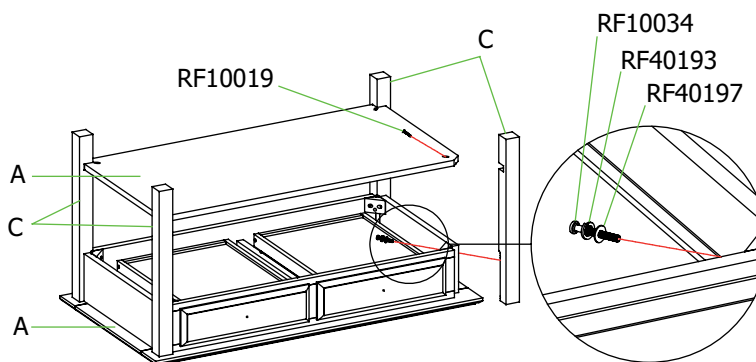

Diagram 3.

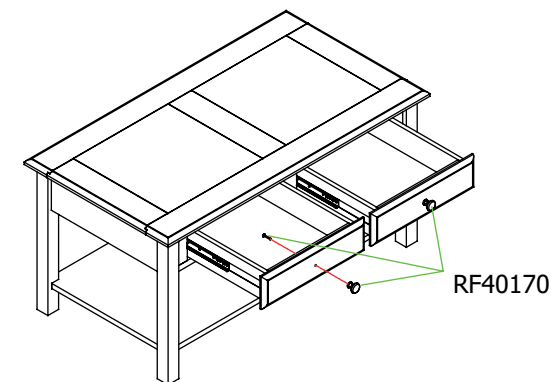

Diagram 4.

Step 3. Attach final leg(C) into the bottom shelf(B) using screw F6 x 1"(RF10019) and table top set(A) by using screw JCB M6 x 50 mm(RF10034), spring washer(RF40193) and washer(RF40197) as per Diag. 3.

Step 4. Upright the unit into the position. Slide the drawer before attach the handle knobs (RF40170) into each drawer as per Diag. 4.

