

MAUI WAVE PANEL BED

KING SIZE

ASSEMBLY INSTRUCTIONS



PARTS AND FITTING PACKAGING DETAIL

BOX #1

A. HEADBOARD 1 PC

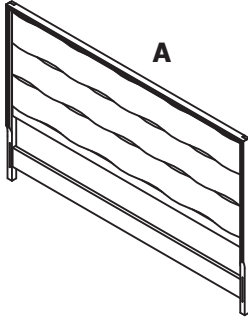

BOX #2

B. FOOTBOARD 1 PC

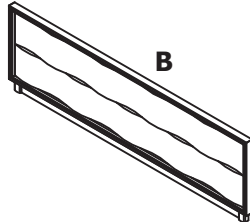

BOX #3

C. SIDERAIL 2 PCS

D. SLAT 3 PCS

E. LEG SUPPORT 6 PCS

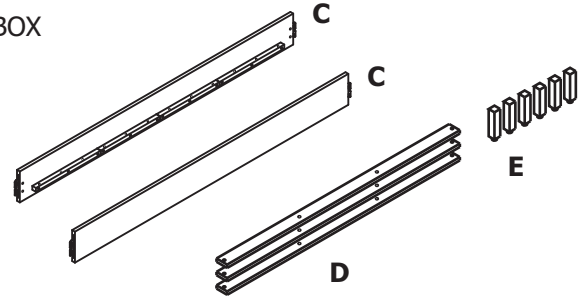

HARDWARE BOX

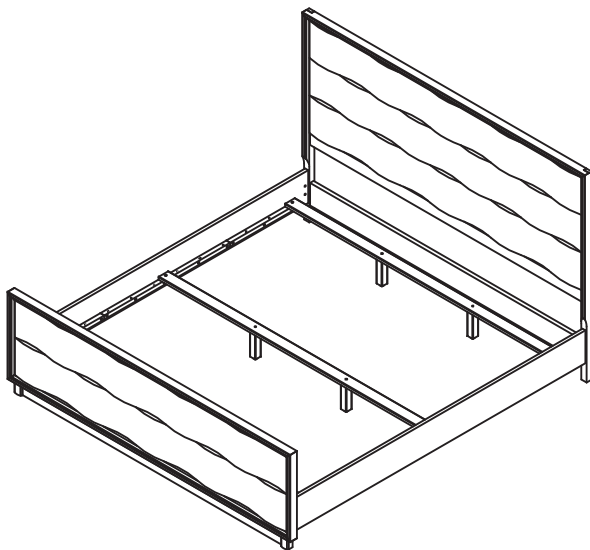

MAUI WAVE PANEL BED ASSEMBLED

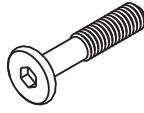

HARDWARE PACKED IN BOX #3

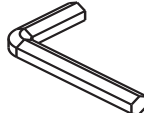
1	ALLEN BOLT 40MM	6 PCS	2	WOOD SCREW Ø8X30MM	6 PCS
					
3	ALLEN KEY	1 PC			
		YOUR BOX MAY CONTAIN EXTRA HARDWARE			

TOOL REQUIRED :

PHILLIPS HEAD SCREW
DRIVER (NOT PROVIDED)

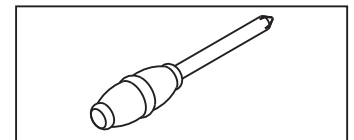

STEP 1 :

FIX ONE OF THE SIDERAIL (C) TO THE HEADBOARD (A) BY SLIDING IN THE HOOK INSTALLED AT THE END OF THE SIDERAIL (C) TO THE HEADBOARD (A), AND PUSH DOWN THE SIDERAIL (C) TO SECURE THE CONNECTION.

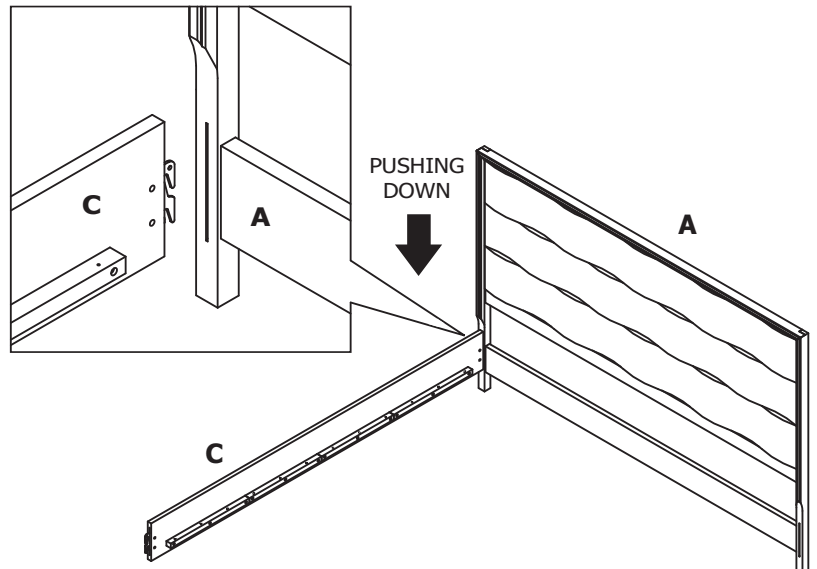

STEP 2 :

FIX THE OTHER END OF THE SIDERAIL (C) TO THE FOOTBOARD (B).

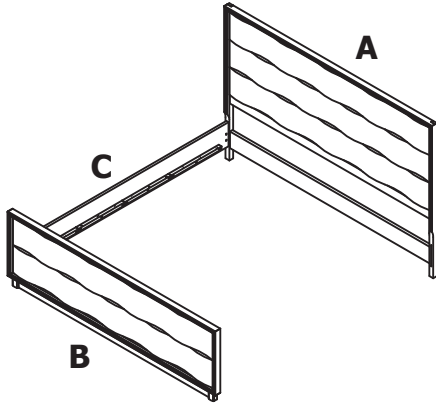
**STEP 3 :**

REPEAT THE SAME WAYS TO FIX THE OTHER SIDERAIL (C) TO THE HEADBOARD (A) AND FOOTBOARD (B).

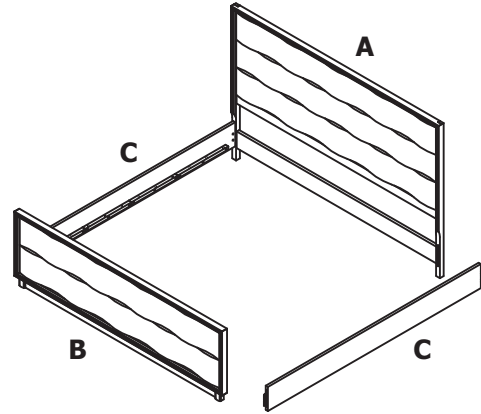
**STEP 4 :**

FOLLOW THE ILLUSTRATION TO PLACE THREE BED SLATS (D) ON THE BED FRAME AND SECURE THE BED SLATS (D) USING WOOD SCREWS (2). USE THE PILOT HOLES ON THE SIDERAILS (C) AS YOUR REFERENCE FOR EASY ASSEMBLY.

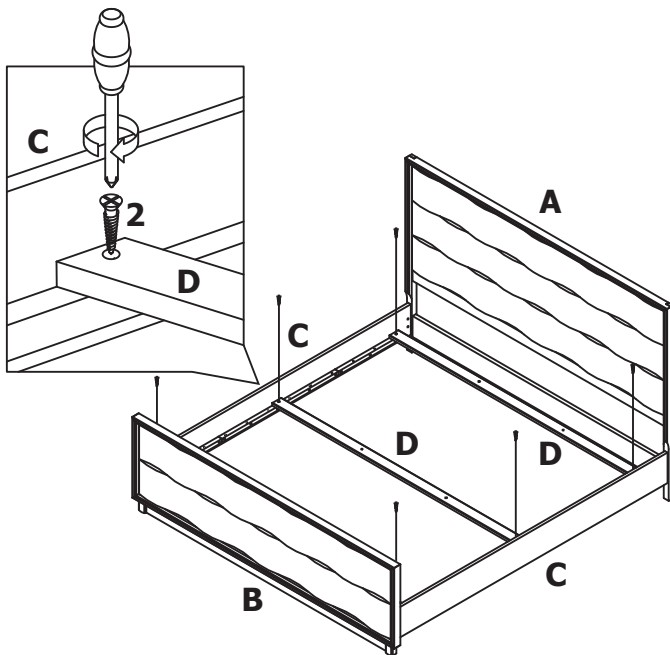
**STEP 5 :**

FOLLOW THE ILLUSTRATION TO FIX THE LEG SUPPORTS (E) TO BED SLATS (D) USING ALLEN BOLTS (1). USE ALLEN KEY (3) TO TIGHTEN THE BOLTS. MAKE SURE ALL BOLTS AND SCREWS ARE TIGHTENED BEFORE USING.

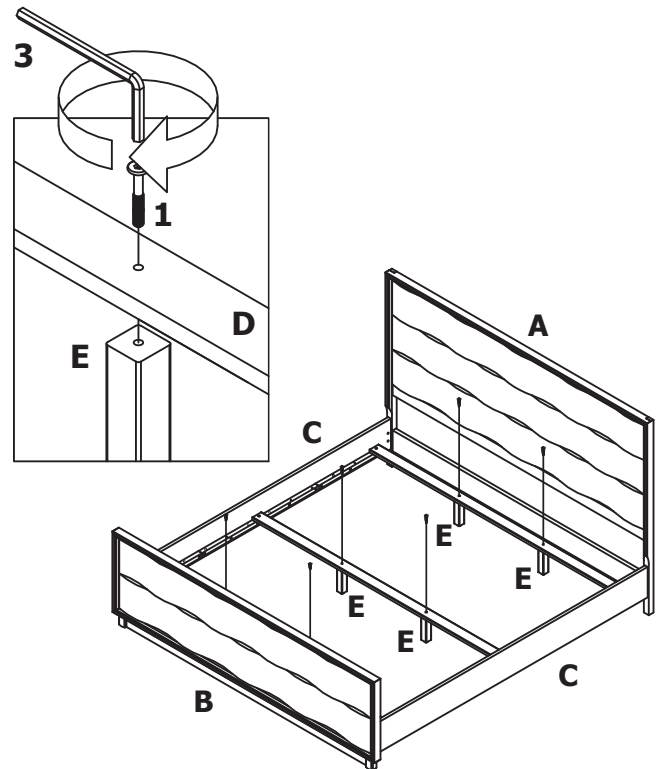

INSTRUCTIONS FOR ADJUSTING LEVELERS:

POSITION THE BED IN YOUR ROOM. LOCATE LEVELERS UNDER EACH LEG SUPPORT (E).

TURN COUNTER-CLOCKWISE TO EXTEND, CLOCKWISE TO CONTRACT.

ADJUST LEVELERS UNTIL EACH LEG SUPPORT IS APPLYING EQUAL UPWARD PRESSURE ON THE BED SLAT.

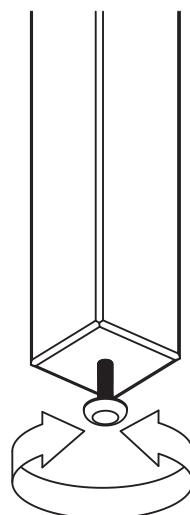

MAINTENANCE INSTRUCTIONS:

- REMOVE BOX SPRING AND MATTRESS BEFORE MOVING YOUR BED.
- LIFT YOUR BED WHEN MOVING IT. DRAGGING CAN DAMAGE LEG SUPPORT.
- READJUST LEVELERS AFTER MOVING YOUR BED.